

**NOTES:**

1. ALL DIMENSIONS ARE IN INCHES UNLESS OTHERWISE SPECIFIED.
2. MATERIAL: 304SS
3. UNIT WEIGHT: \_\_\_\_ LBS

**PROPRIETARY AND CONFIDENTIAL**  
 THE INFORMATION CONTAINED IN THIS DRAWING IS THE SOLE PROPERTY OF STARFIRE DIRECT. ANY REPRODUCTION IN PART OR AS A WHOLE WITHOUT THE WRITTEN PERMISSION OF STARFIRE DIRECT IS PROHIBITED.

ITEM NO.	QTY.	PART NUMBER	DESCRIPTION
4	2	-	RECTANGLE 1.5" x 4.5" SUPPORT PLATE
3	1	-	AL RND TUBE 1.25" OD x 0.125" WALL
2	3	-	END CAP, 1/8" THK
1	2	-	AL RND TUBE 0.75 OD x 0.059 WALL

UNLESS OTHERWISE SPECIFIED:		NAME	DATE	TITLE:	
DIMENSIONS ARE IN INCHES		DRAWN		<b>FIRE PIT T-BURNER - 18"</b>	
TOLERANCES:		CHECKED			
FRACTIONAL: ± 1/8"		ENG APPR.			
ANGULAR: MACH ± BEND ±		MFG APPR.			
TWO PLACE DECIMAL ±		Q.A.		SIZE	DWG. NO.
THREE PLACE DECIMAL ±				<b>B</b>	SD-FPT-18
INTERPRET GEOMETRIC TOLERANCING PER:				SCALE: 1:5	WEIGHT:
MATERIAL				SHEET 1 OF 1	
FINISH					
DO NOT SCALE DRAWING					



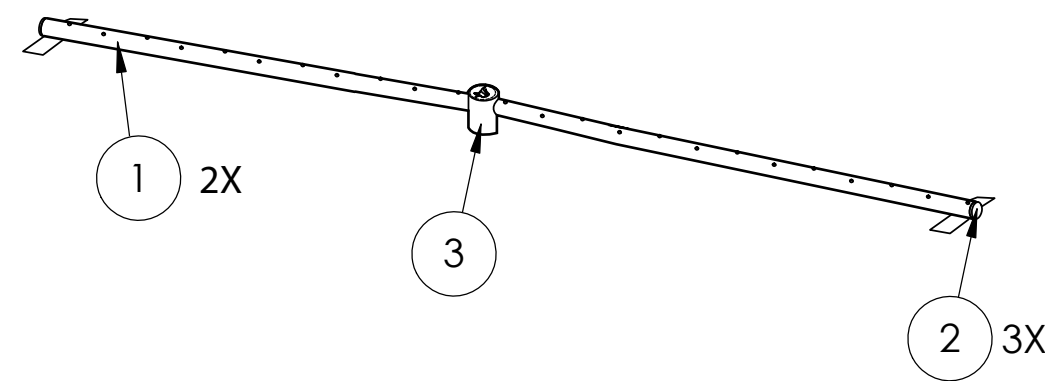
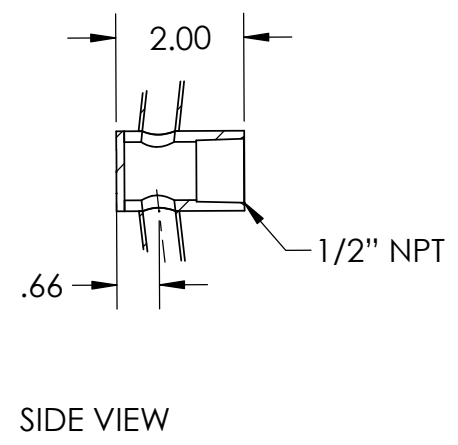
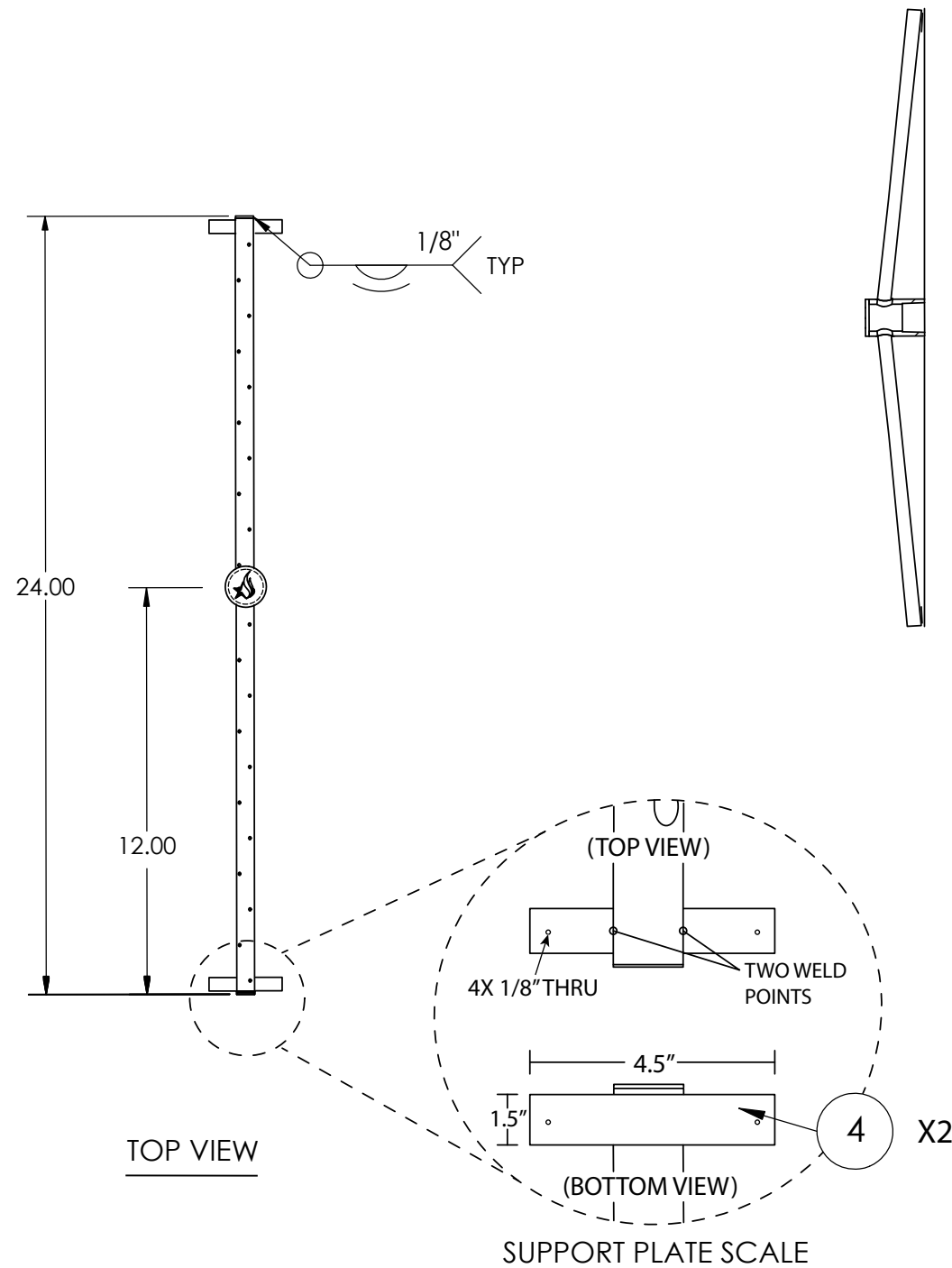

ISOMETRIC VIEW

ITEM NO.	QTY.	PART NUMBER	DESCRIPTION
4	2	-	RECTANGLE 1.5" x 4.5" SUPPORT PLATE
3	1	-	AL RND TUBE 1.25" OD x 0.125" WALL
2	3	-	END CAP, 1/8" THK
1	2	-	AL RND TUBE 0.75 OD x 0.059 WALL

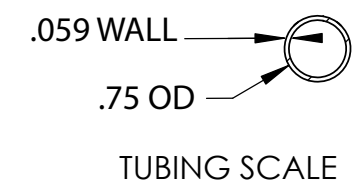

**NOTES:**

- ALL DIMENSIONS ARE IN INCHES UNLESS OTHERWISE SPECIFIED.
- MATERIAL: 304SS
- UNIT WEIGHT: \_\_\_\_ LBS

**PROPRIETARY AND CONFIDENTIAL**  
 THE INFORMATION CONTAINED IN THIS DRAWING IS THE SOLE PROPERTY OF STARFIRE DIRECT. ANY REPRODUCTION IN PART OR AS A WHOLE WITHOUT THE WRITTEN PERMISSION OF STARFIRE DIRECT IS PROHIBITED.

UNLESS OTHERWISE SPECIFIED:		NAME	DATE	TITLE:	
DIMENSIONS ARE IN INCHES		DRAWN		<b>FIRE PIT T-BURNER - 24"</b>	
TOLERANCES:		CHECKED			
FRACTIONAL: ± 1/8"		ENG APPR.			
ANGULAR: MACH ± BEND ±		MFG APPR.			
TWO PLACE DECIMAL ±		Q.A.		SIZE	DWG. NO.
THREE PLACE DECIMAL ±				<b>B</b>	SD-FPT-24
INTERPRET GEOMETRIC TOLERANCING PER:				SCALE: 1:5	WEIGHT:
MATERIAL				REV	
FINISH				<b>A</b>	
DO NOT SCALE DRAWING				SHEET 1 OF 1	

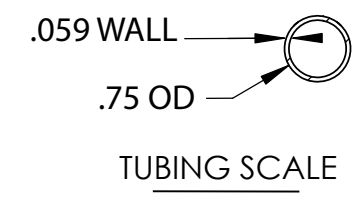
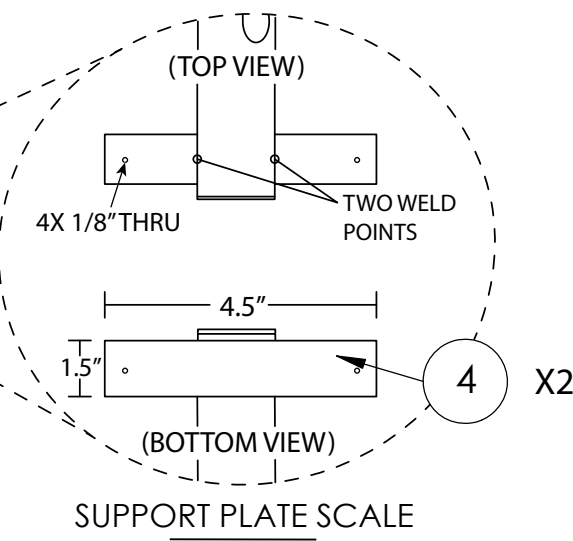
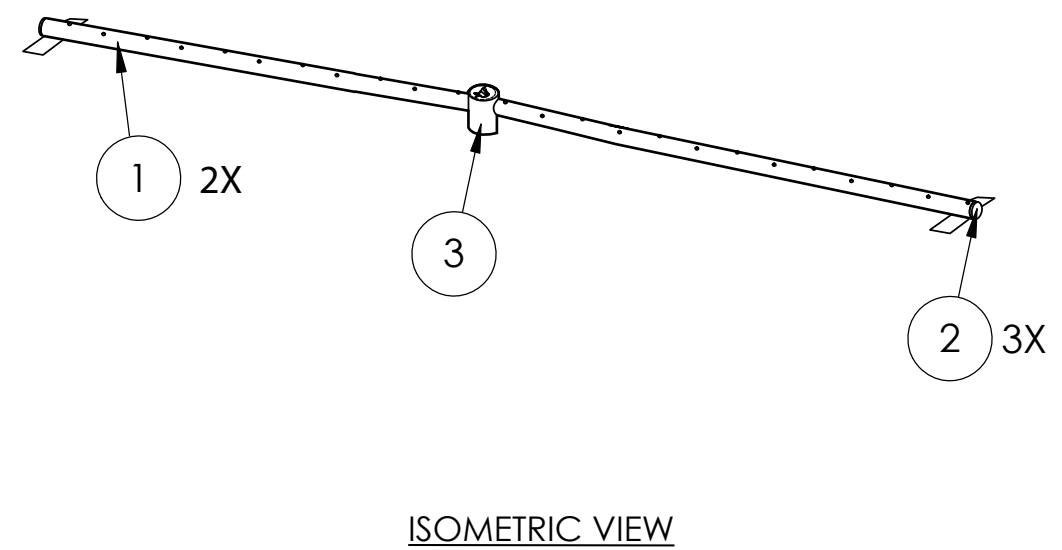
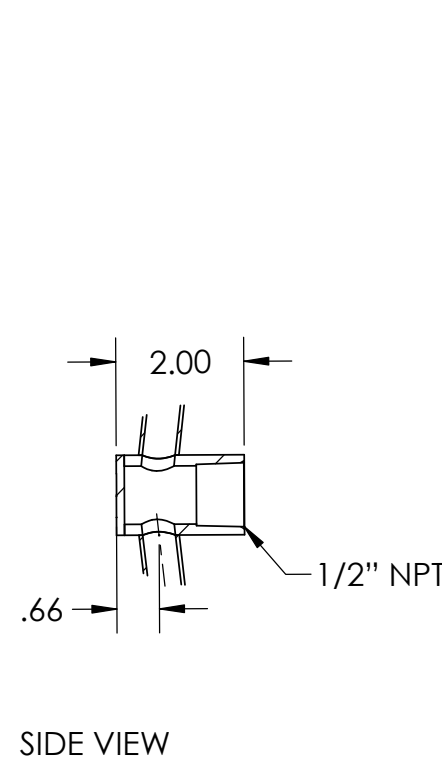
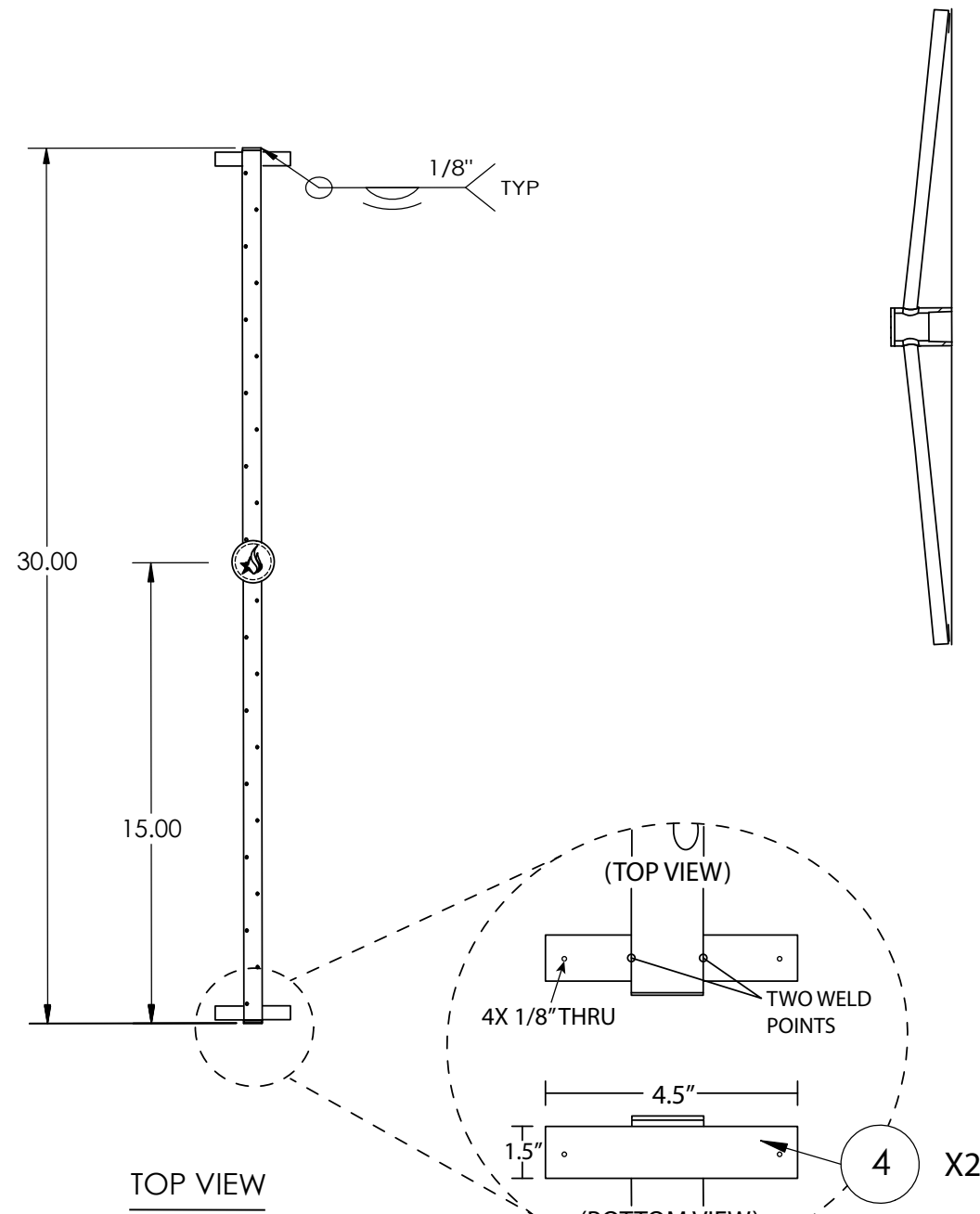

ITEM NO.	QTY.	PART NUMBER	DESCRIPTION
4	2	-	RECTANGLE 1.5" x 4.5" SUPPORT PLATE
3	1	-	AL RND TUBE 1.25" OD x 0.125" WALL
2	3	-	END CAP, 1/8" THK
1	2	-	AL RND TUBE 0.75 OD x 0.059 WALL

**NOTES:**

- ALL DIMENSIONS ARE IN INCHES UNLESS OTHERWISE SPECIFIED.
- MATERIAL: 304SS
- UNIT WEIGHT: \_\_\_\_ LBS

**PROPRIETARY AND CONFIDENTIAL**  
 THE INFORMATION CONTAINED IN THIS DRAWING IS THE SOLE PROPERTY OF STARFIRE DIRECT. ANY REPRODUCTION IN PART OR AS A WHOLE WITHOUT THE WRITTEN PERMISSION OF STARFIRE DIRECT IS PROHIBITED.

UNLESS OTHERWISE SPECIFIED:		NAME	DATE	TITLE:	
DIMENSIONS ARE IN INCHES		DRAWN		<b>FIRE PIT T-BURNER - 30"</b>	
TOLERANCES:		CHECKED			
FRACTIONAL ± 1/8"		ENG APPR.			
ANGULAR: MACH ± BEND ±		MFG APPR.			
TWO PLACE DECIMAL ±		Q.A.		SIZE	DWG. NO.
THREE PLACE DECIMAL ±				<b>B</b>	SD-FPT-30
INTERPRET GEOMETRIC TOLERANCING PER:				REV	<b>A</b>
MATERIAL				SCALE: 1:5	WEIGHT:
FINISH				SHEET 1 OF 1	
DO NOT SCALE DRAWING					

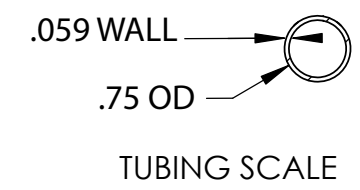
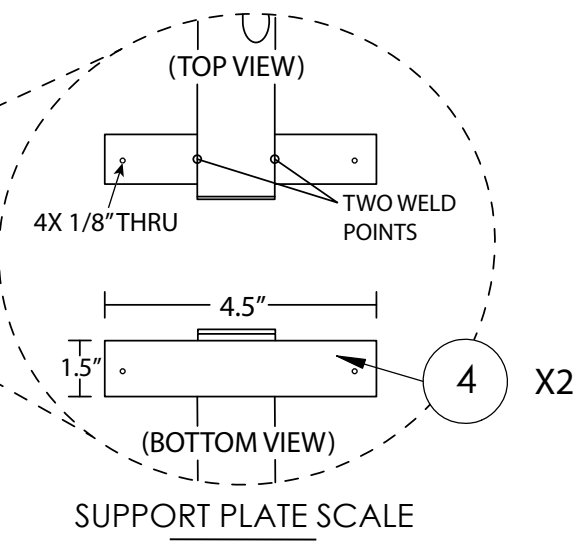
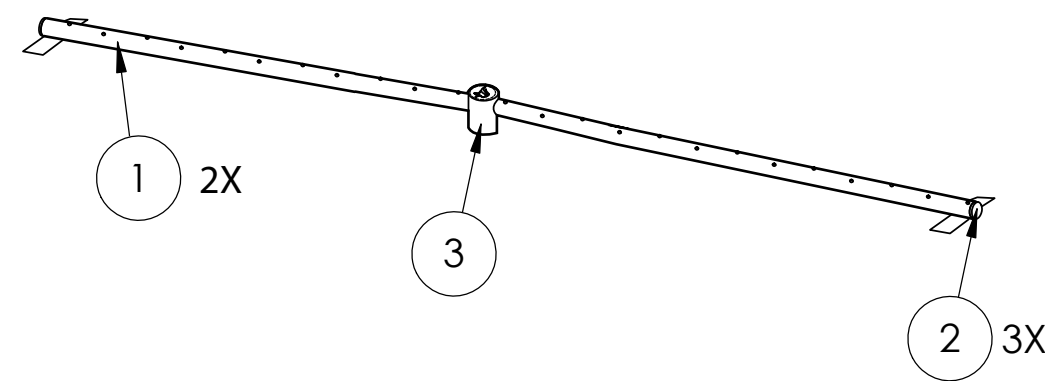
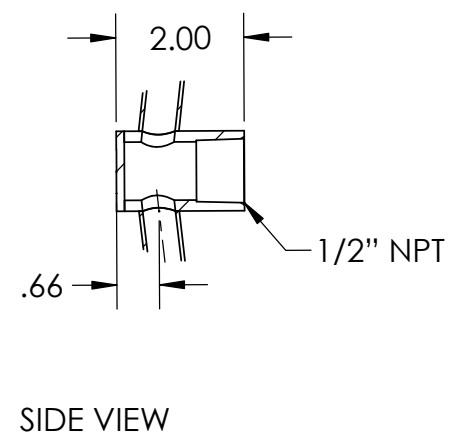
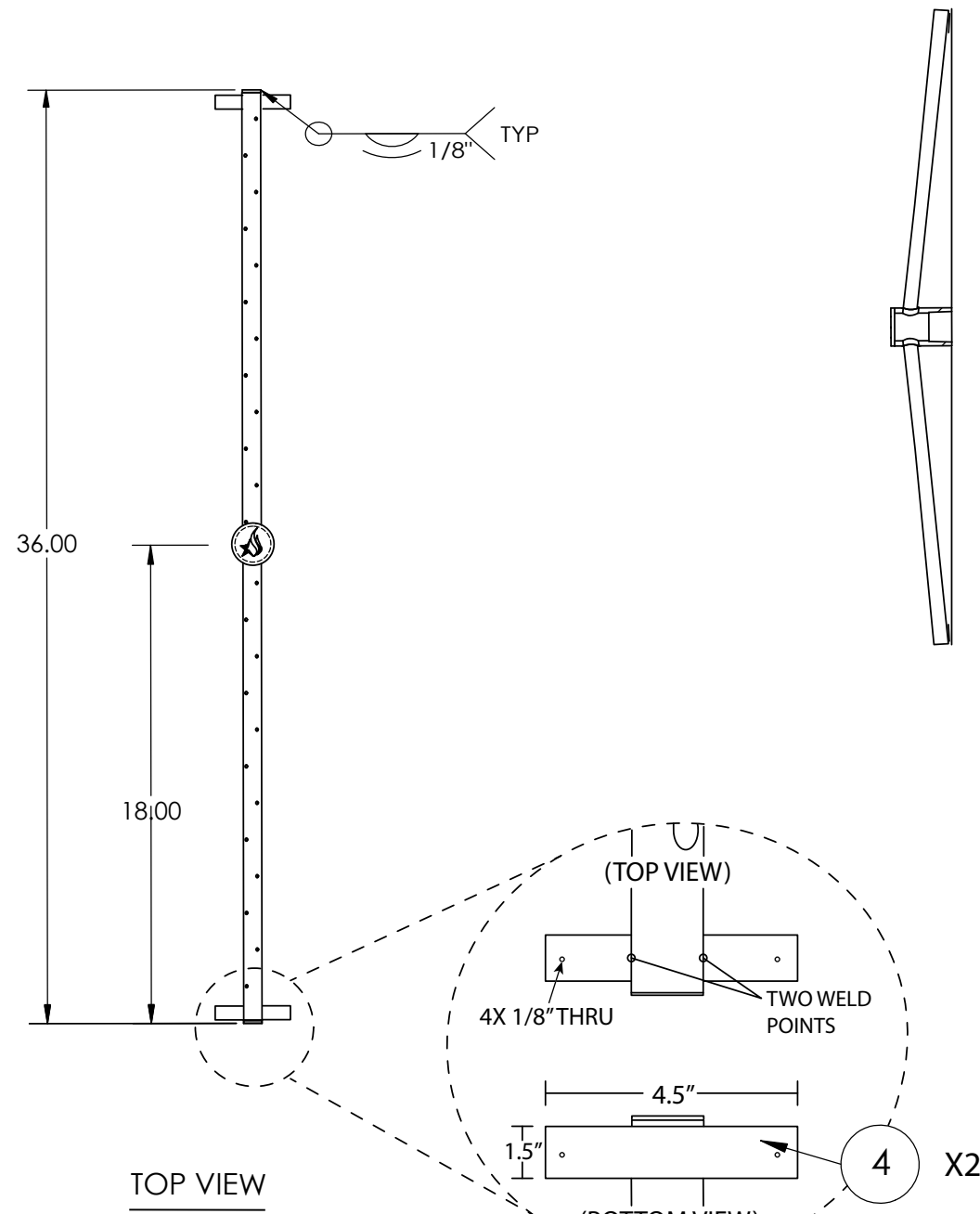

ITEM NO.	QTY.	PART NUMBER	DESCRIPTION
4	2	-	RECTANGLE 1.5" x 4.5" SUPPORT PLATE
3	1	-	AL RND TUBE 1.25" OD x 0.125" WALL
2	3	-	END CAP, 1/8" THK
1	2	-	AL RND TUBE 0.75 OD x 0.059 WALL

**NOTES:**

- ALL DIMENSIONS ARE IN INCHES UNLESS OTHERWISE SPECIFIED.
- MATERIAL: 304SS
- UNIT WEIGHT: \_\_\_\_ LBS

**PROPRIETARY AND CONFIDENTIAL**  
 THE INFORMATION CONTAINED IN THIS DRAWING IS THE SOLE PROPERTY OF STARFIRE DIRECT. ANY REPRODUCTION IN PART OR AS A WHOLE WITHOUT THE WRITTEN PERMISSION OF STARFIRE DIRECT IS PROHIBITED.

UNLESS OTHERWISE SPECIFIED:

DRAWN	NAME	DATE
CHECKED		
ENG APPR.		
MFG APPR.		
Q.A.		

STARFIRE DESIGNS

TITLE: FIRE PIT T-BURNER - 36"

SIZE	DWG. NO.	REV
<b>B</b>	SD-FPT-36	<b>A</b>
SCALE: 1:5	WEIGHT:	SHEET 1 OF 1

DIMENSIONS ARE IN INCHES  
 TOLERANCES:  
 FRACTIONAL ± 1/8"  
 ANGULAR: MACH ± BEND ±  
 TWO PLACE DECIMAL ±  
 THREE PLACE DECIMAL ±

INTERPRET GEOMETRIC TOLERANCING PER:

MATERIAL

FINISH

DO NOT SCALE DRAWING

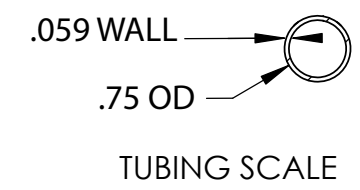
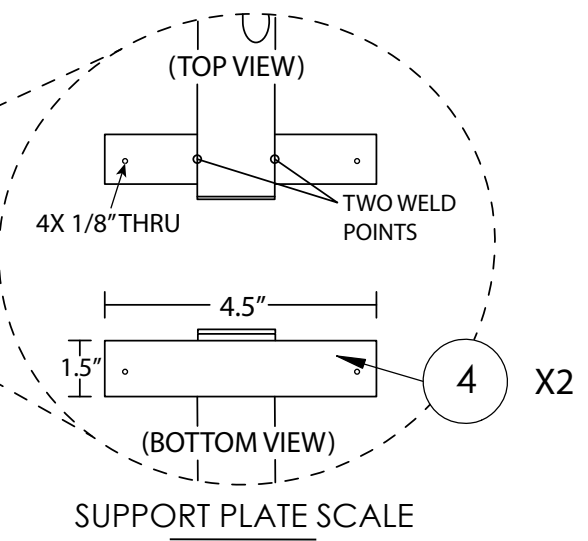
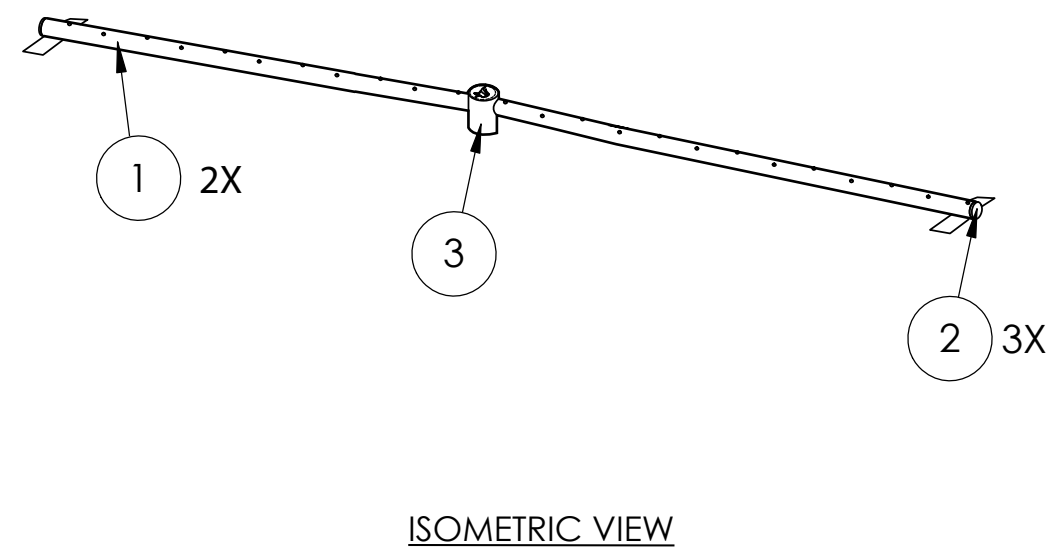
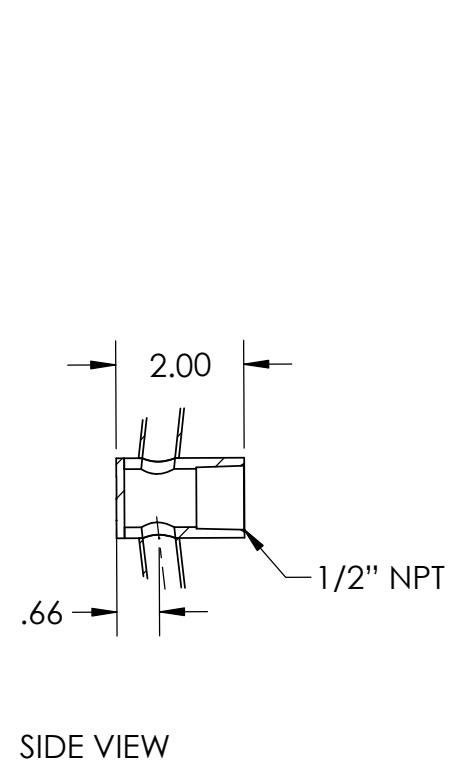
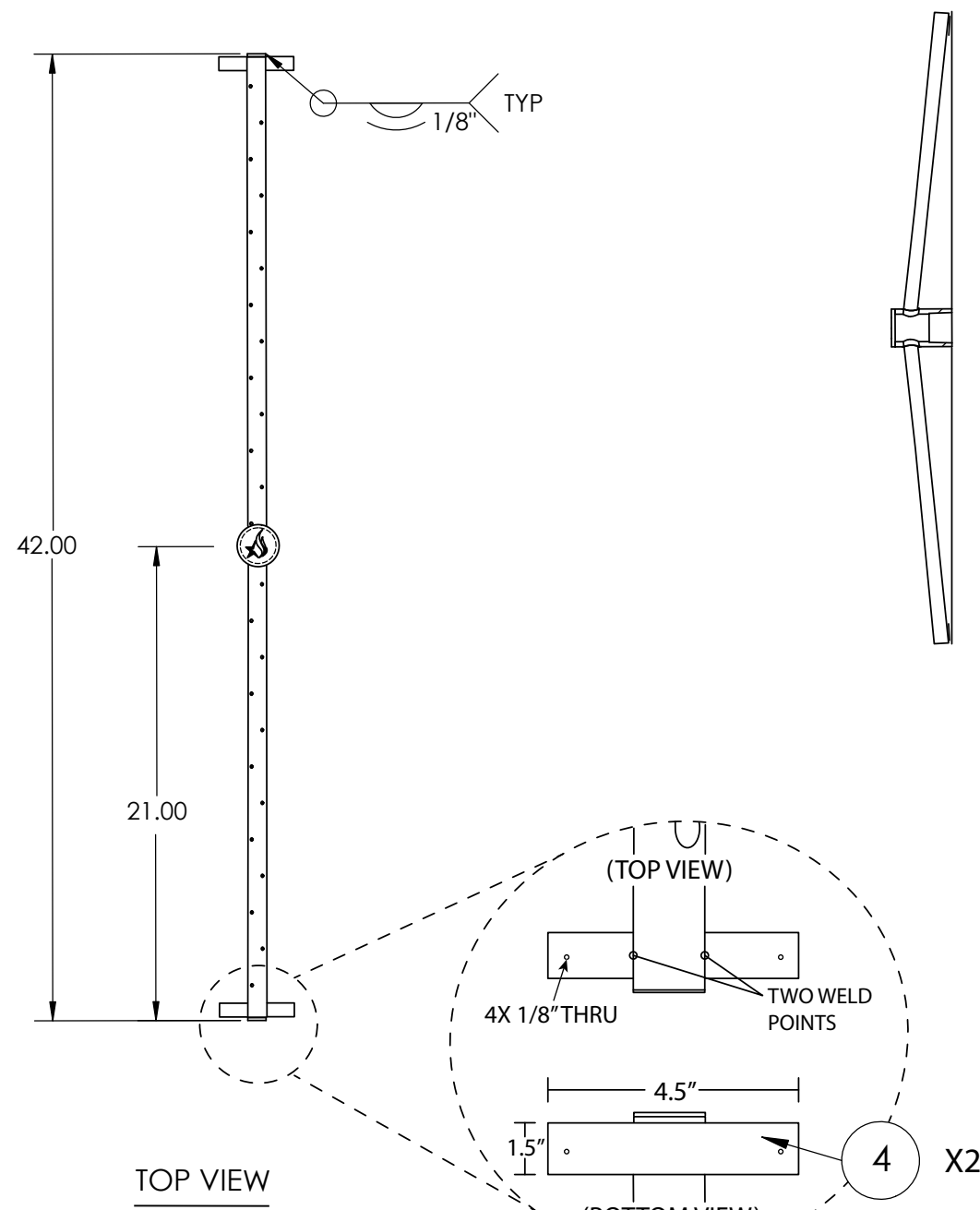

ITEM NO.	QTY.	PART NUMBER	DESCRIPTION
4	2	-	RECTANGLE 1.5" x 4.5" SUPPORT PLATE
3	1	-	AL RND TUBE 1.25" OD x 0.125" WALL
2	3	-	END CAP, 1/8" THK
1	2	-	AL RND TUBE 0.75 OD x 0.059 WALL

**NOTES:**

- ALL DIMENSIONS ARE IN INCHES UNLESS OTHERWISE SPECIFIED.
- MATERIAL: 304SS
- UNIT WEIGHT: \_\_\_\_ LBS

**PROPRIETARY AND CONFIDENTIAL**  
 THE INFORMATION CONTAINED IN THIS DRAWING IS THE SOLE PROPERTY OF STARFIRE DIRECT. ANY REPRODUCTION IN PART OR AS A WHOLE WITHOUT THE WRITTEN PERMISSION OF STARFIRE DIRECT IS PROHIBITED.

UNLESS OTHERWISE SPECIFIED:		NAME	DATE	TITLE:	
DIMENSIONS ARE IN INCHES	DRAWN			<b>FIRE PIT T-BURNER - 42"</b>	
TOLERANCES:	CHECKED				
FRACTIONAL ± 1/8"	ENG APPR.				
ANGULAR: MACH ± BEND ±	MFG APPR.				
TWO PLACE DECIMAL ±	Q.A.				
THREE PLACE DECIMAL ±					
INTERPRET GEOMETRIC TOLERANCING PER:			SIZE	DWG. NO.	REV
MATERIAL			<b>B</b>	SD-FPT-42	<b>A</b>
FINISH			SCALE: 1:5	WEIGHT:	SHEET 1 OF 1
DO NOT SCALE DRAWING					

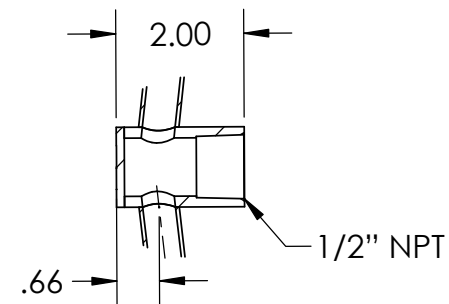
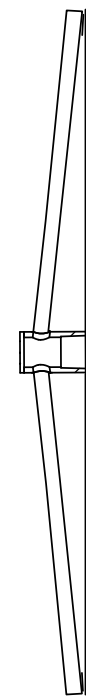
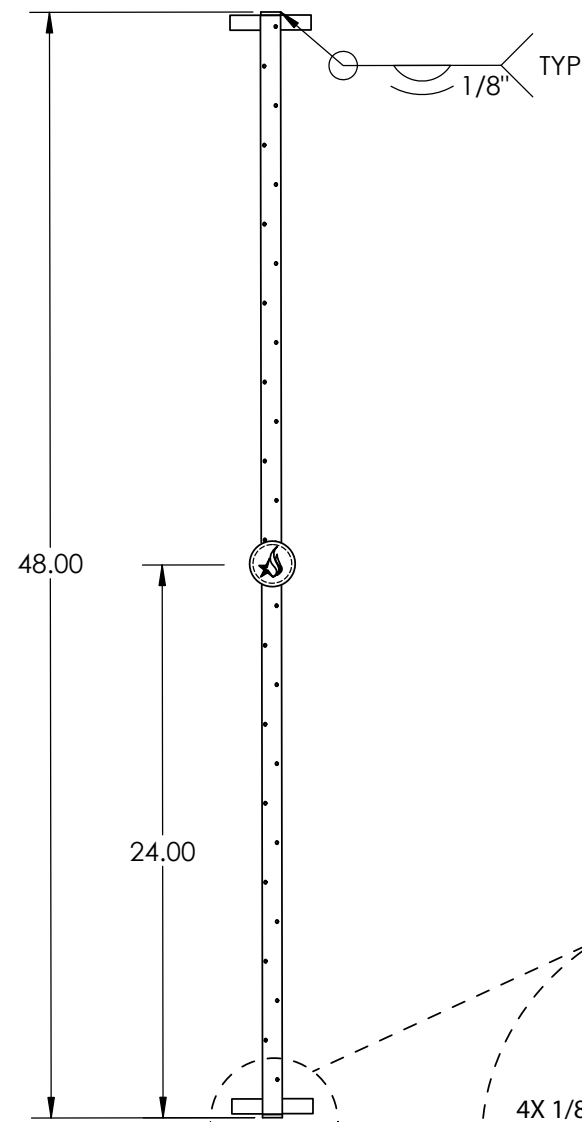

SIDE VIEW

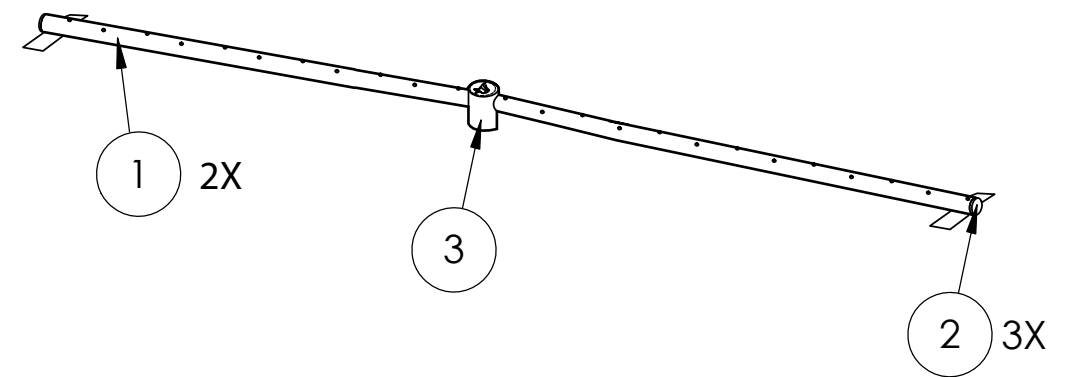

ISOMETRIC VIEW

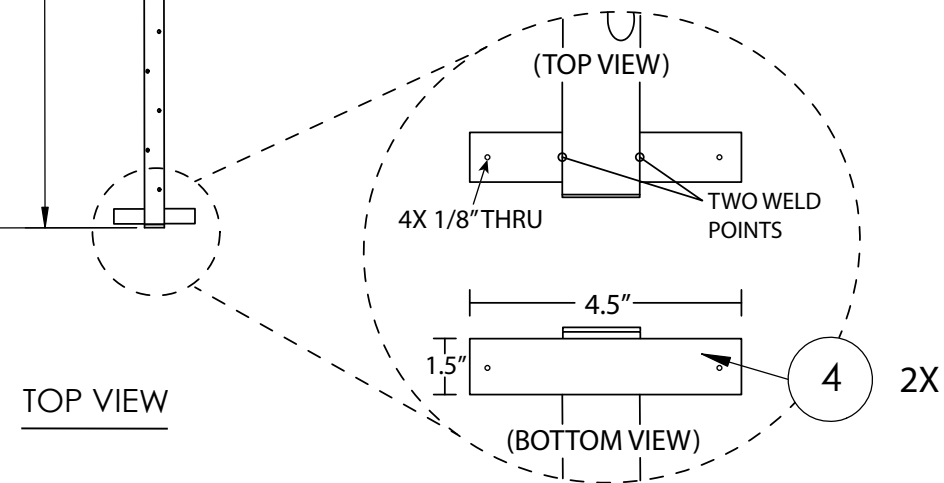

TOP VIEW

SUPPORT PLATE SCALE

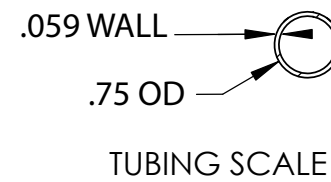

TUBING SCALE

ITEM NO.	QTY.	PART NUMBER	DESCRIPTION
4	2	-	RECTANGLE 1.5" x 4.5" SUPPORT PLATE
3	1	-	AL RND TUBE 1.25" OD x 0.125" WALL
2	3	-	END CAP, 1/8" THK
1	2	-	AL RND TUBE 0.75 OD x 0.059 WALL

**NOTES:**

- ALL DIMENSIONS ARE IN INCHES UNLESS OTHERWISE SPECIFIED.
- MATERIAL: 304SS
- UNIT WEIGHT: \_\_\_\_ LBS

**PROPRIETARY AND CONFIDENTIAL**  
 THE INFORMATION CONTAINED IN THIS DRAWING IS THE SOLE PROPERTY OF STARFIRE DIRECT. ANY REPRODUCTION IN PART OR AS A WHOLE WITHOUT THE WRITTEN PERMISSION OF STARFIRE DIRECT IS PROHIBITED.

UNLESS OTHERWISE SPECIFIED:		NAME	DATE	TITLE:	
DIMENSIONS ARE IN INCHES	DRAWN			<b>FIRE PIT T-BURNER - 48"</b>	
TOLERANCES:	CHECKED				
FRACTIONAL ± 1/8"	ENG APPR.				
ANGULAR: MACH ± BEND ±	MFG APPR.				
TWO PLACE DECIMAL ±	Q.A.				
THREE PLACE DECIMAL ±					
INTERPRET GEOMETRIC TOLERANCING PER:			SIZE	DWG. NO.	REV
MATERIAL			<b>B</b>	SD-FPT-48	<b>A</b>
FINISH			SCALE: 1:5	WEIGHT:	SHEET 1 OF 1
DO NOT SCALE DRAWING					