

# Gravity Collection | 60" x 24" x 16"

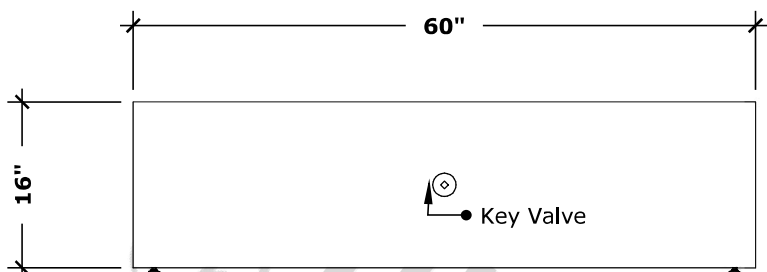

**FRONT VIEW**

scale: 1/2" = 1'-0" (1:24)

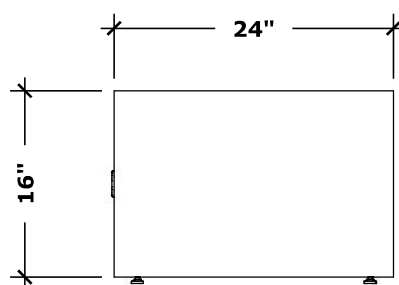

**RIGHT VIEW**

scale: 1/2" = 1'-0" (1:24)

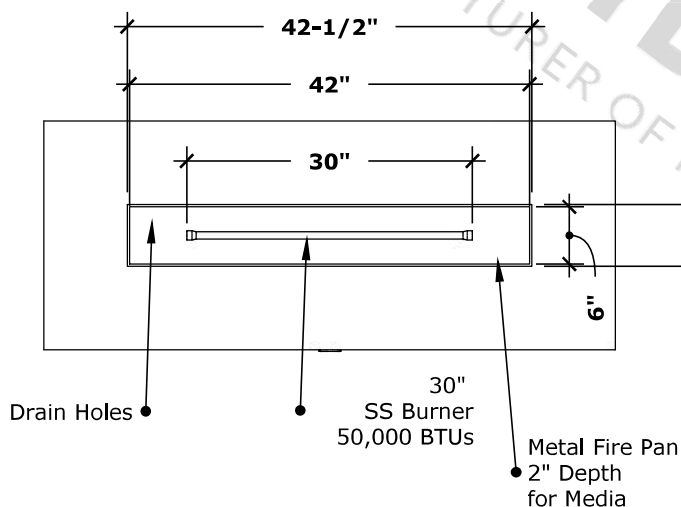

**TOP VIEW**

scale: 1/2" = 1'-0" (1:24)

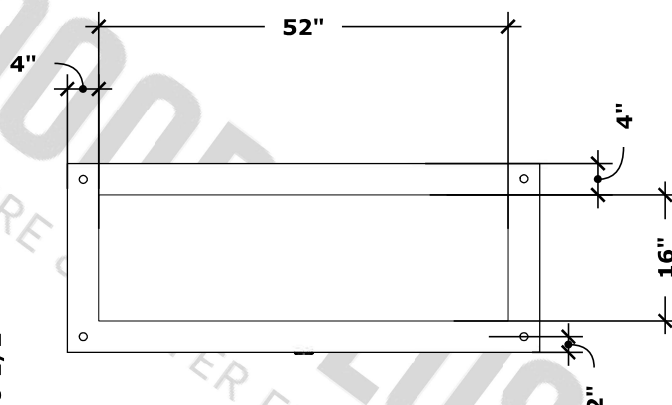

**UNDERSIDE VIEW**

scale: 1/2" = 1'-0" (1:24)

Fire Pit Material: Copper, Powder Coated Steel, Stainless Steel, or Corten Steel  
 Pan Material: 316 Stainless Steel  
 Burner Material: 316 Stainless Steel  
 Gas Type: Liquid Propane or Natural Gas

**Match Lit Unit Includes:** Pan, Burner, Gas Orifice, Gas Hoses, Key Valve, Key, & Lava Chunks.

**110v Ignition Unit Includes:** Pan, Burner, Gas Orifice, Gas Hoses, Key Valve, Key, Plug & Play Electronic Valve, Pilot Igniter.



**110V ELECTRONIC IGNITION CERTIFICATION**  
 ANSI Z21.97-(2017) / CSA 2.41-(2017)