

4

3

2

1

B

B

A

A

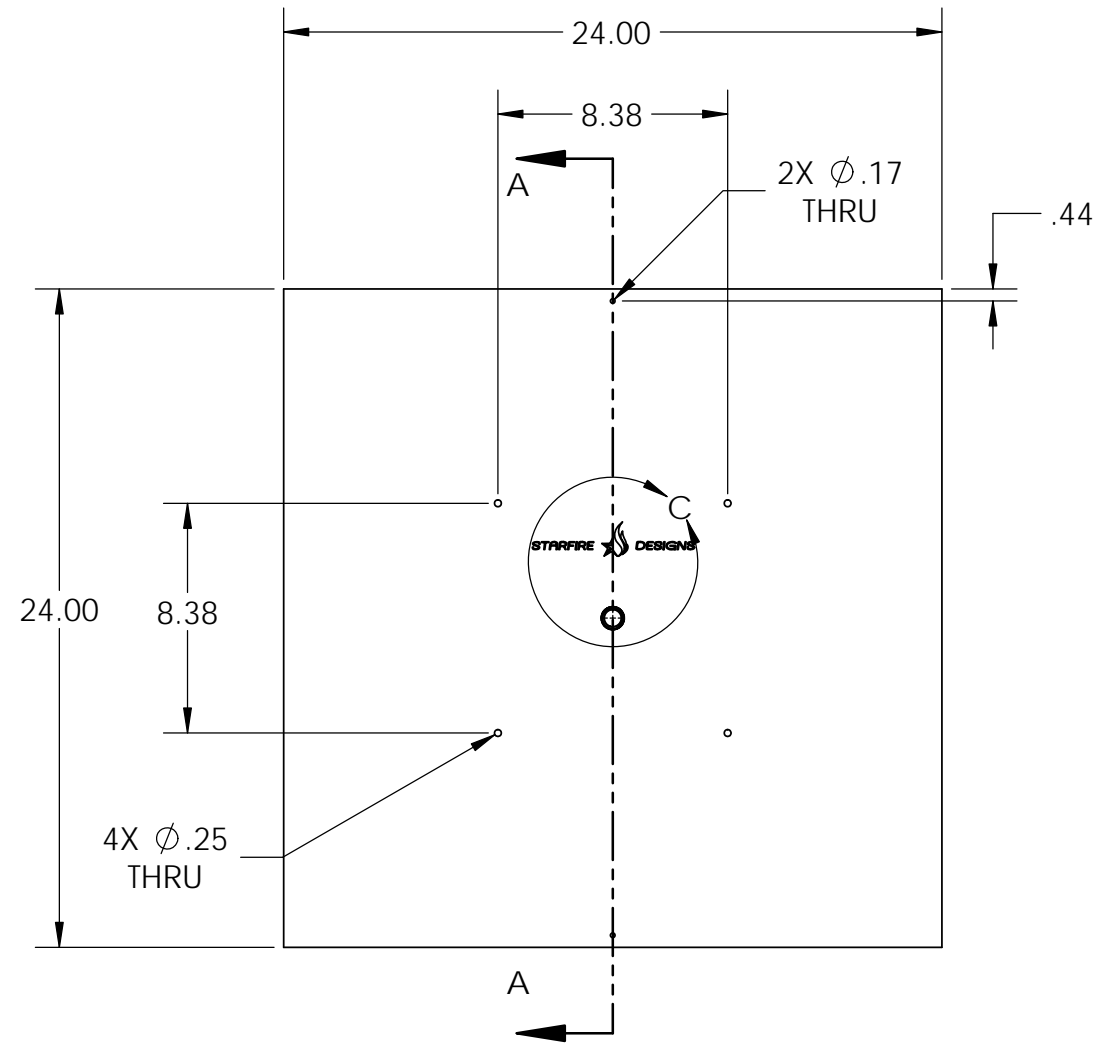

TOP VIEW

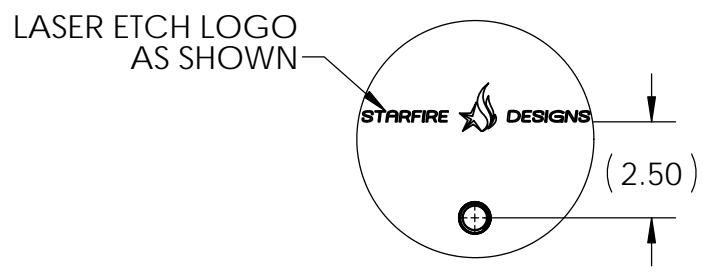

DETAIL C
SCALE 1 : 5

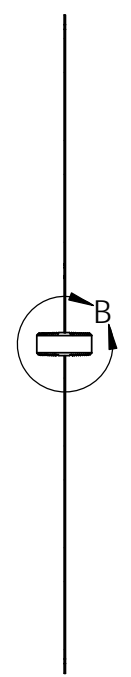

SECTION A-A

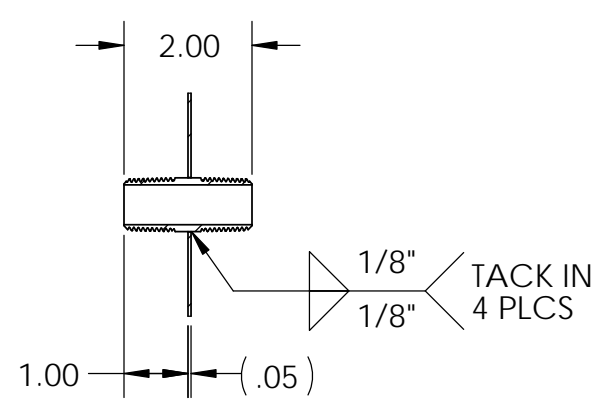

DETAIL B
SCALE 1 : 3

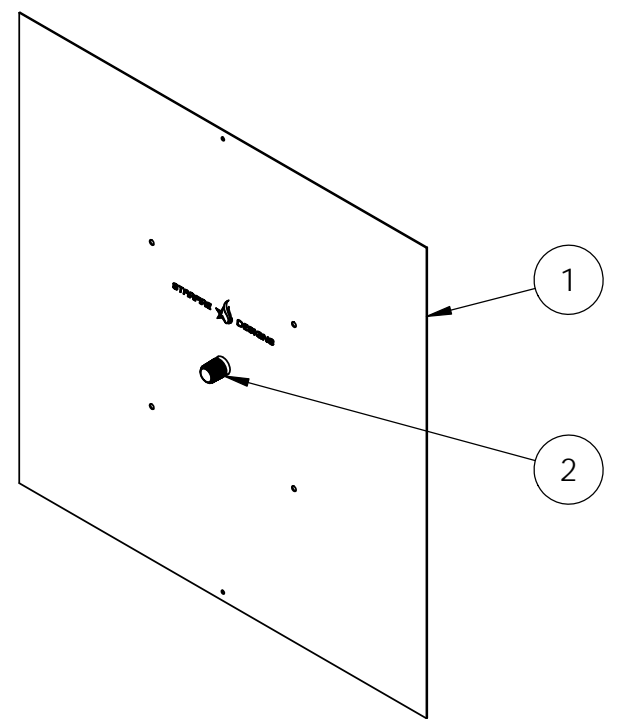

ISOMETRIC VIEW

- NOTES:**
1. ALL DIMENSIONS ARE IN INCHES UNLESS OTHERWISE SPECIFIED.
 2. MATERIAL: 304SS
 3. UNIT WEIGHT: ____ LBS

ITEM NO.	QTY.	PART NUMBER	DESCRIPTION
2	1	-	SS THRD PIPE NIPPLE, 1/2 NPT X 2" LONG
1	1	PAN-SQR-24	24" SQUARE SS PAN

PROPRIETARY AND CONFIDENTIAL
 THE INFORMATION CONTAINED IN THIS DRAWING IS THE SOLE PROPERTY OF STARFIRE DIRECT. ANY REPRODUCTION IN PART OR AS A WHOLE WITHOUT THE WRITTEN PERMISSION OF STARFIRE DIRECT IS PROHIBITED.

UNLESS OTHERWISE SPECIFIED:		NAME	DATE	TITLE: SQUARE BURNER PAN - 24" X 24"
DIMENSIONS ARE IN INCHES		DRAWN		
TOLERANCES:		CHECKED		
FRACTIONAL: ± 1/8"		ENG APPR.		
ANGULAR: MACH ± BEND ±		MFG APPR.		
TWO PLACE DECIMAL ±		Q.A.		
THREE PLACE DECIMAL ±				
INTERPRET GEOMETRIC TOLERANCING PER:		SIZE	DWG. NO.	REV
MATERIAL		B	PAN-SQR-24	A
NEXT ASSY	USED ON	FINISH	SCALE: 1:7	WEIGHT:
APPLICATION		DO NOT SCALE DRAWING		SHEET 1 OF 1

4

3

2

1

4

3

2

1

B

B

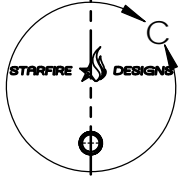
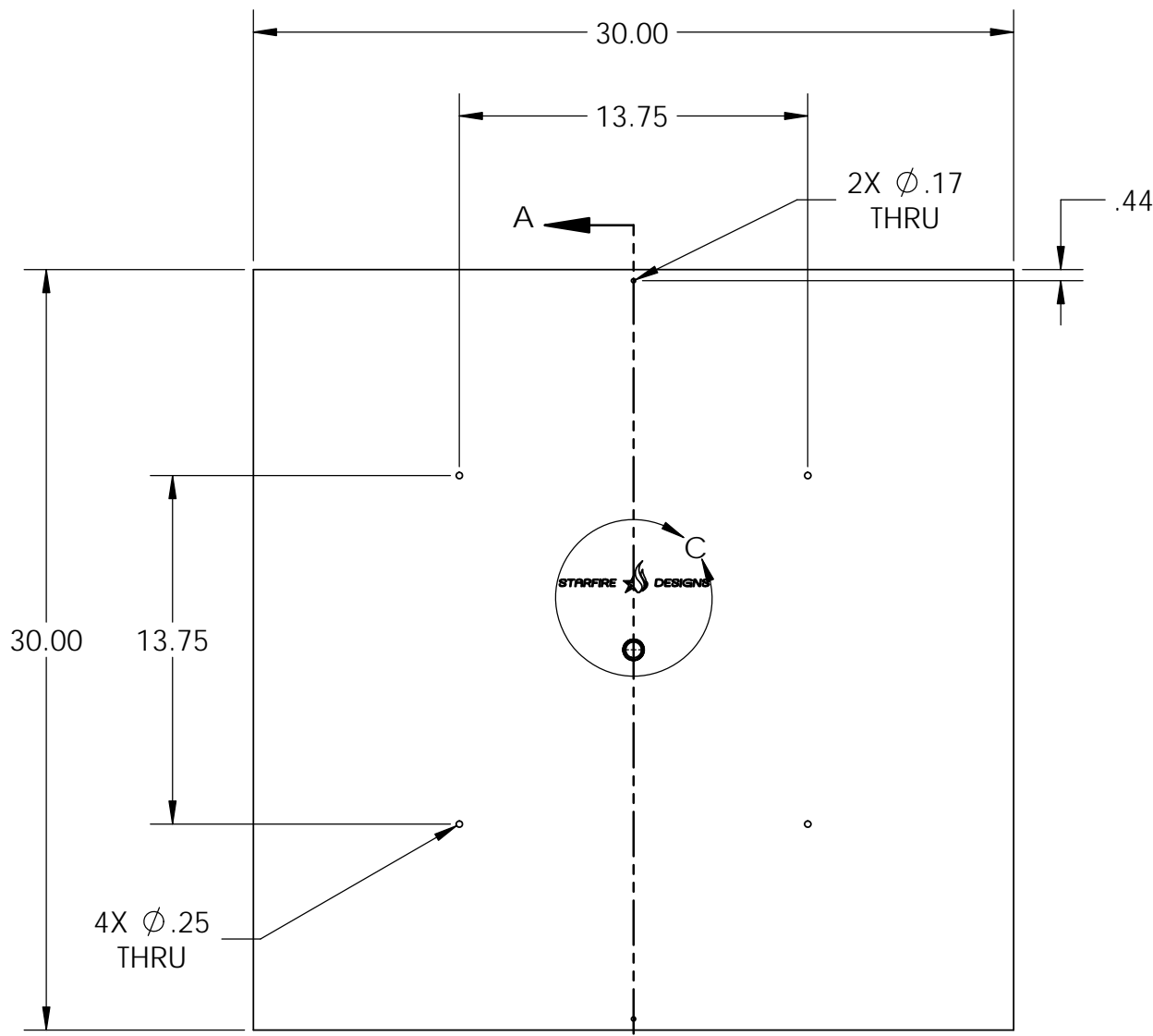

LASER ETCH LOGO AS SHOWN

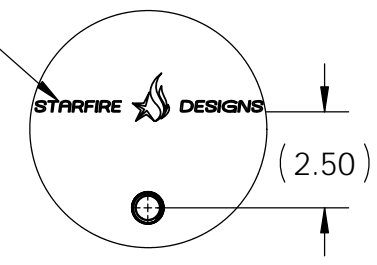

DETAIL C
SCALE 1 : 5

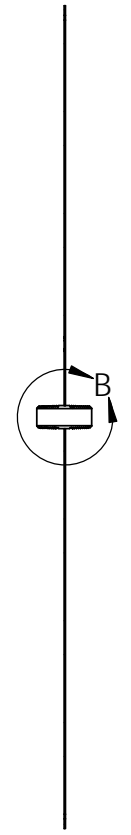

SECTION A-A

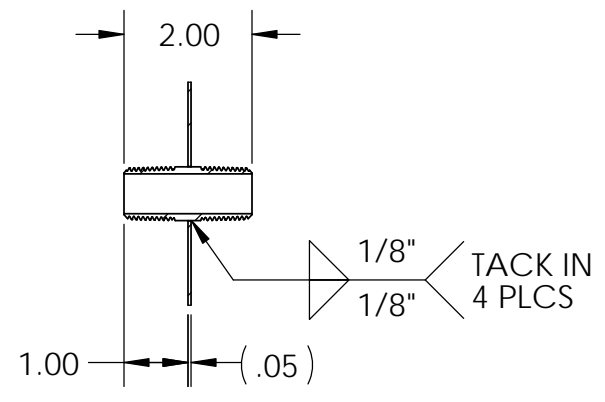

DETAIL B
SCALE 1 : 3

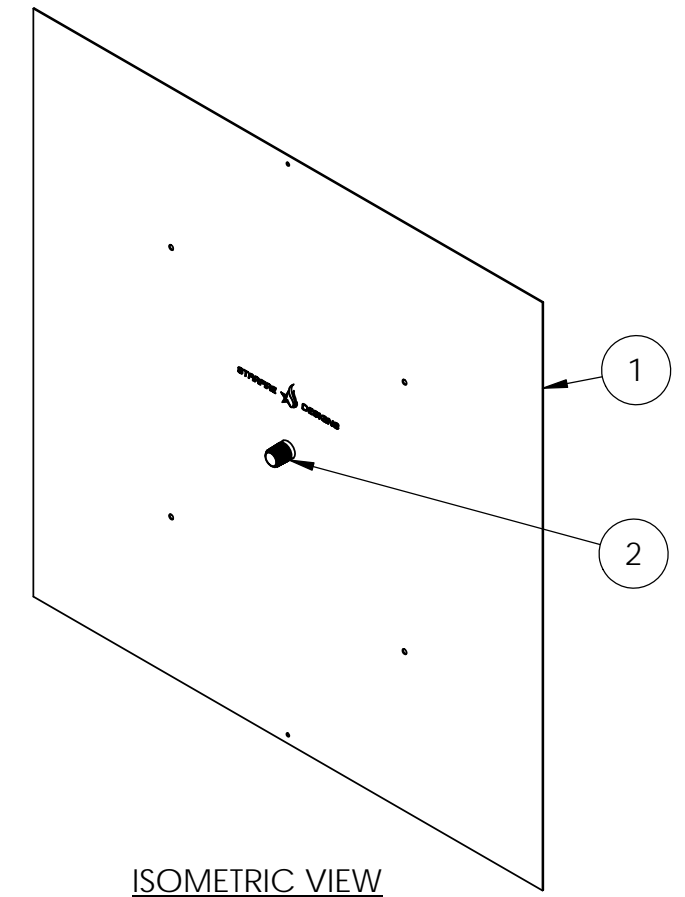

ISOMETRIC VIEW

- NOTES:**
1. ALL DIMENSIONS ARE IN INCHES UNLESS OTHERWISE SPECIFIED.
 2. MATERIAL: 304SS
 3. UNIT WEIGHT: ____ LBS

ITEM NO.	QTY.	PART NUMBER	DESCRIPTION
2	1	-	SS THRD PIPE NIPPLE, 1/2 NPT X 2" LONG
1	1	PAN-SQR-30	30" SQUARE SS PAN

PROPRIETARY AND CONFIDENTIAL
 THE INFORMATION CONTAINED IN THIS DRAWING IS THE SOLE PROPERTY OF STARFIRE DIRECT. ANY REPRODUCTION IN PART OR AS A WHOLE WITHOUT THE WRITTEN PERMISSION OF STARFIRE DIRECT IS PROHIBITED.

UNLESS OTHERWISE SPECIFIED:		NAME	DATE	TITLE:
DIMENSIONS ARE IN INCHES		DRAWN		SQUARE BURNER PAN - 30" X 30"
TOLERANCES:		CHECKED		
FRACTIONAL: ± 1/8"		ENG APPR.		
ANGULAR: MACH ± BEND ±		MFG APPR.		
TWO PLACE DECIMAL ±		Q.A.		SIZE
THREE PLACE DECIMAL ±		MATERIAL		DWG. NO.
INTERPRET GEOMETRIC TOLERANCING PER:				PAN-SQR-30
FINISH				REV
NEXT ASSY	USED ON	SCALE: 1:7		WEIGHT:
APPLICATION		DO NOT SCALE DRAWING		SHEET 1 OF 1

4

3

2

1

A

A