

# Mill & Edge | 40" x 40" x 18"

FP-404018

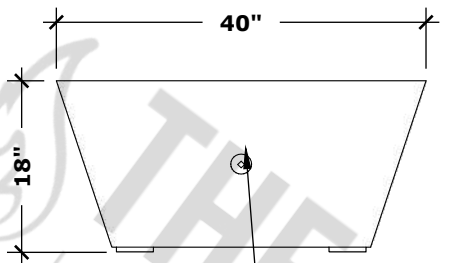

Manufactured By **THE OUTDOOR PLUS**  
USA MANUFACTURER OF FIRE & WATER FEATURES



● Key Valve

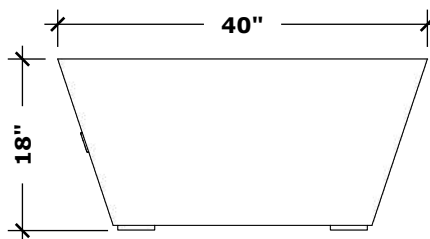

**FRONT VIEW**

scale: 1/2" = 1'-0" (1:24)

**RIGHT VIEW**

scale: 1/2" = 1'-0" (1:24)

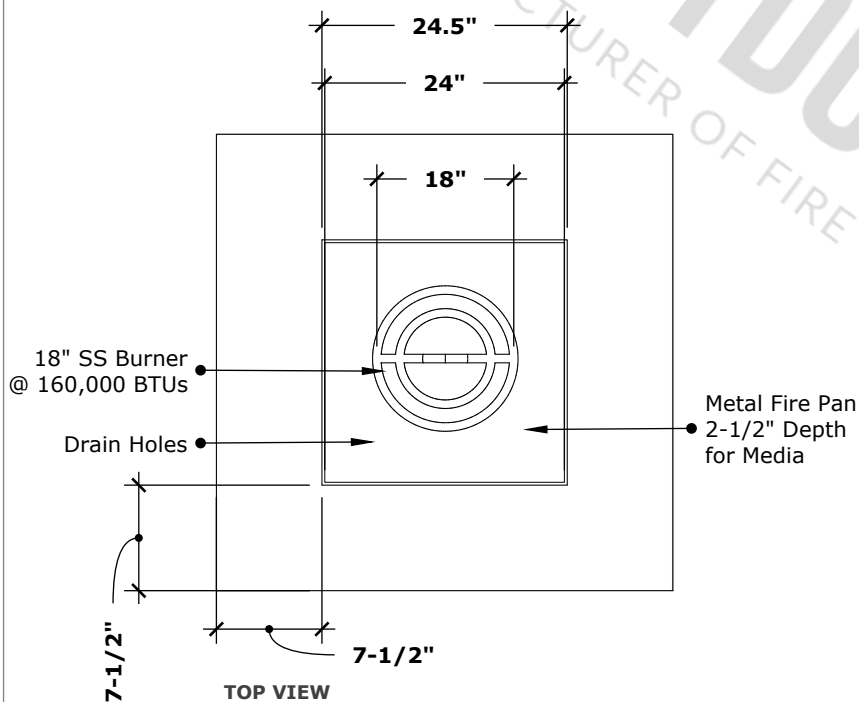

**TOP VIEW**

scale: 1/2" = 1'-0" (1:24)

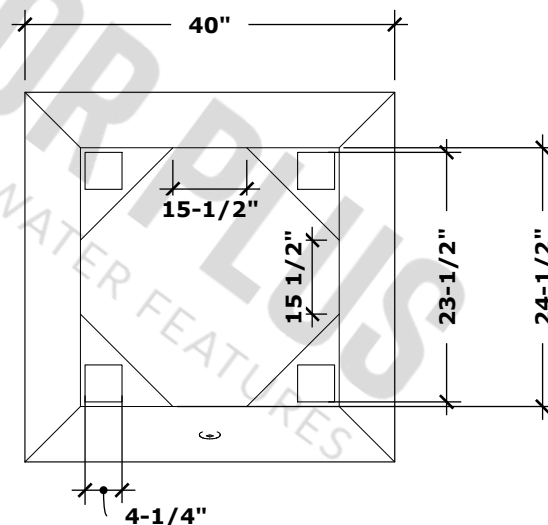

**UNDERSIDE VIEW**

scale: 1/2" = 1'-0" (1:24)

Fire Pit Material: Copper, Powder Coated Steel, Stainless Steel, or Corten Steel

Pan Material: 316 Stainless Steel

Burner Material: 316 Stainless Steel

Gas Type: Liquid Propane or Natural Gas

**Match Lit Unit Includes:** Pan, Burner, Gas Orifice, Gas Hoses, Key Valve, Key, & Lava Chunks.

**110v Ignition Unit Includes:** Pan, Burner, Gas Orifice, Gas Hoses, Key Valve, Key, Plug & Play Electronic Valve, Pilot Igniter.



**110V ELECTRONIC IGNITION CERTIFICATION**  
 ANSI Z21.97-(2017) / CSA 2.41-(2017)

# Mill & Edge | 40" x 40" x 24"

FP-404022



Manufactured By **THE OUTDOOR PLUS**  
USA MANUFACTURER OF FIRE & WATER FEATURES

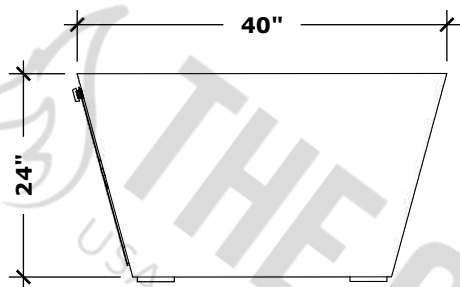

**FRONT VIEW**

scale: 1/2" = 1'-0" (1:24)

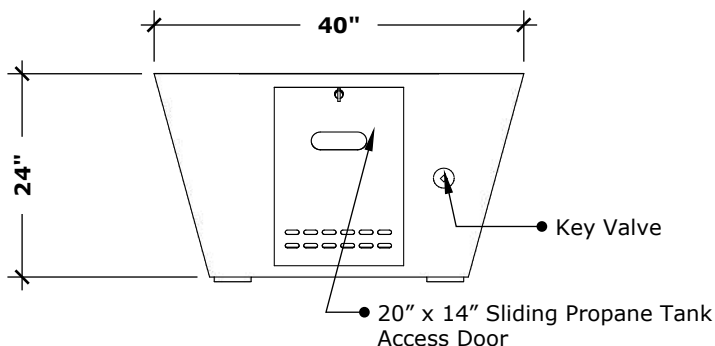

**RIGHT VIEW**

scale: 1/2" = 1'-0" (1:24)

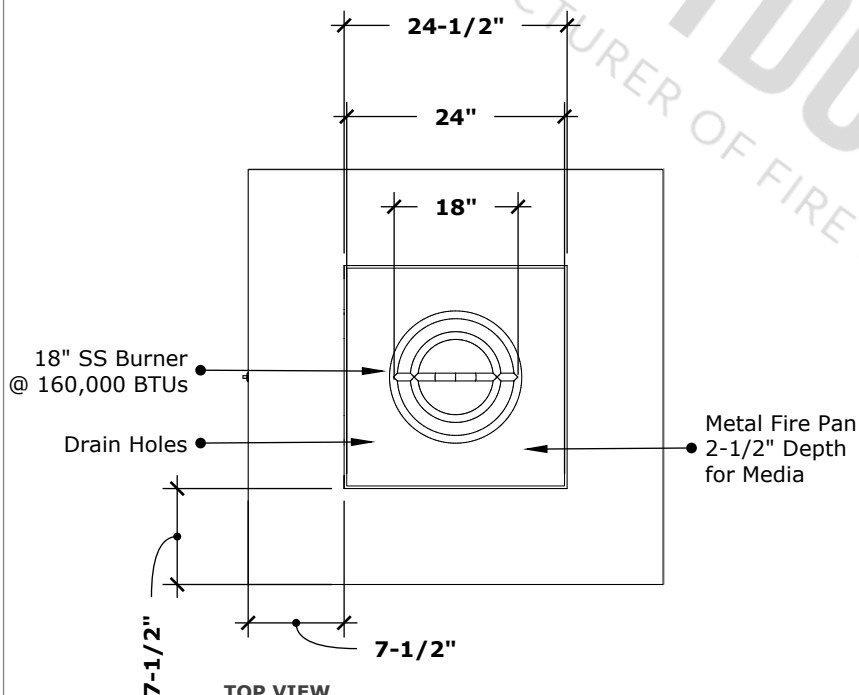

**TOP VIEW**

scale: 1/2" = 1'-0" (1:24)

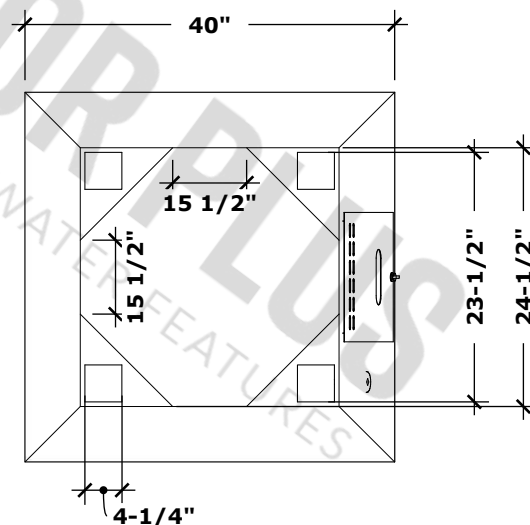

**UNDERSIDE VIEW**

scale: 1/2" = 1'-0" (1:24)

Fire Pit Material: Copper, Powder Coated Steel, Stainless Steel, or Corten Steel

Pan Material: 316 Stainless Steel

Burner Material: 316 Stainless Steel

Gas Type: Liquid Propane (Door Included) or Natural Gas

**Match Lit Unit Includes:** Pan, Burner, Gas Orifice, Gas Hoses, Key Valve, Key, & Lava Chunks.

**110v Ignition Unit Includes:** Pan, Burner, Gas Orifice, Gas Hoses, Key Valve, Key, Plug & Play Electronic Valve, Pilot Igniter.



**110V ELECTRONIC IGNITION CERTIFICATION**  
 ANSI Z21.97-(2017) / CSA 2.41-(2017)

**Mill & Edge | 48" x 48" x 18"**  
**FP-484818**



Manufactured By **THE OUTDOOR PLUS**  
USA MANUFACTURER OF FIRE & WATER FEATURES

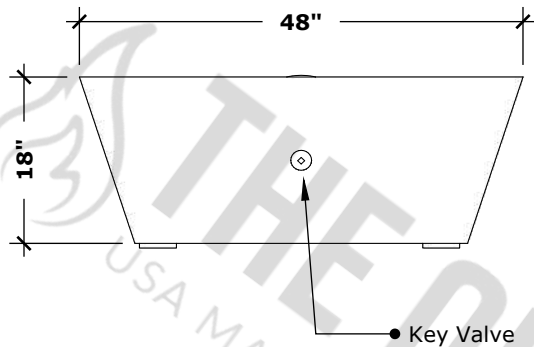

**FRONT VIEW**

scale: 1/2" = 1'-0" (1:24)

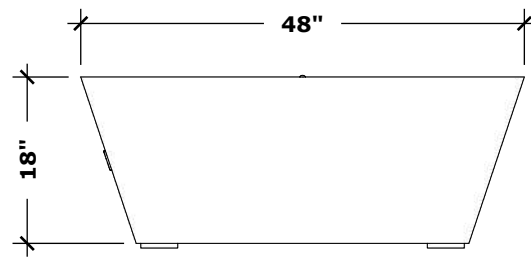

**RIGHT VIEW**

scale: 1/2" = 1'-0" (1:24)

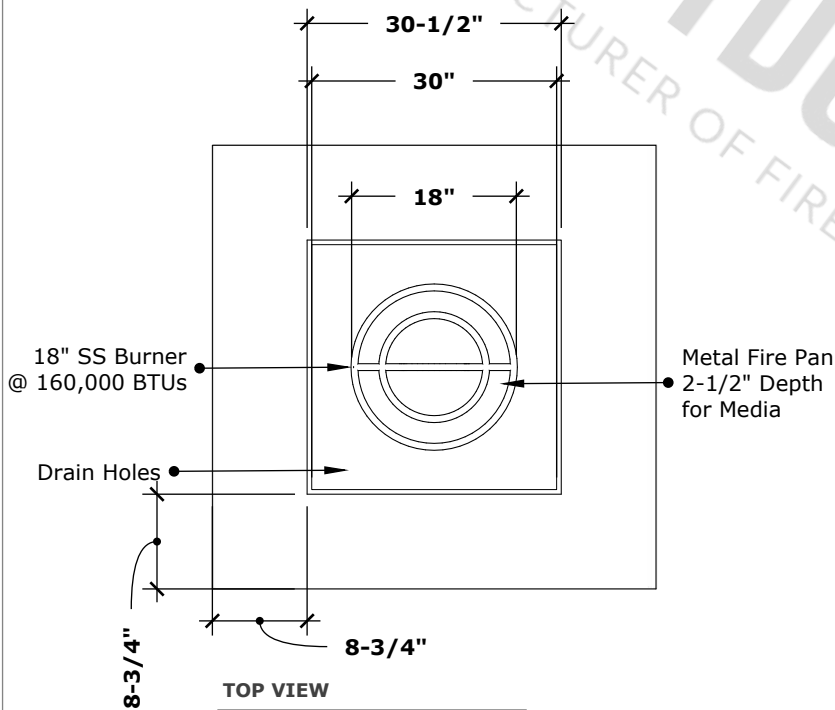

**TOP VIEW**

scale: 1/2" = 1'-0" (1:24)

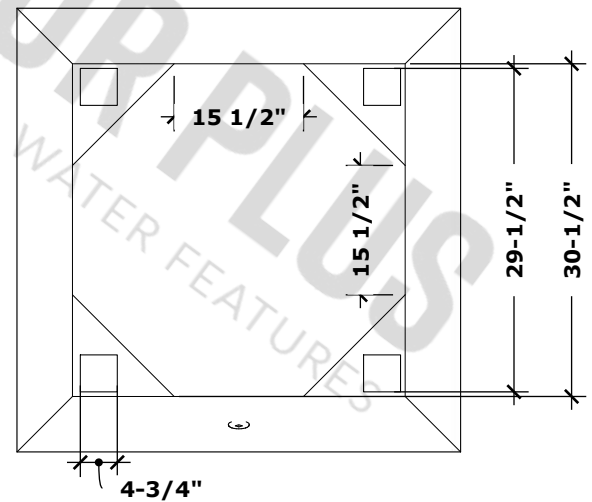

**UNDERSIDE VIEW**

scale: 1/2" = 1'-0" (1:24)

Fire Pit Material: Copper, Powder Coated Steel, Stainless Steel, or Corten Steel  
 Pan Material: 316 Stainless Steel  
 Burner Material: 316 Stainless Steel  
 Gas Type: Liquid Propane or Natural Gas

**Match Lit Unit Includes:** Pan, Burner, Gas Orifice, Gas Hoses, Key Valve, Key, & Lava Chunks.

**110v Ignition Unit Includes:** Pan, Burner, Gas Orifice, Gas Hoses, Key Valve, Key, Plug & Play Electronic Valve, Pilot Igniter.



**110V ELECTRONIC IGNITION CERTIFICATION**  
 ANSI Z21.97-(2017) / CSA 2.41-(2017)

# Mill & Edge | 48" x 48" x 24"

FP-484822



Manufactured By **THE OUTDOOR PLUS**  
USA MANUFACTURER OF FIRE & WATER FEATURES

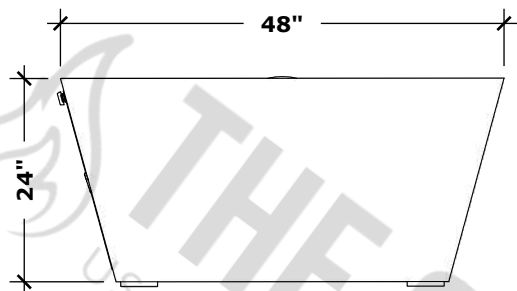

**FRONT VIEW**

scale: 1/2" = 1'-0" (1:24)

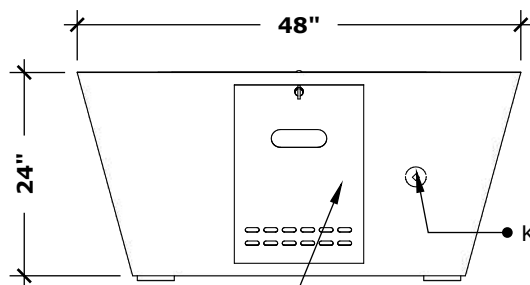

**RIGHT VIEW**

scale: 1/2" = 1'-0" (1:24)

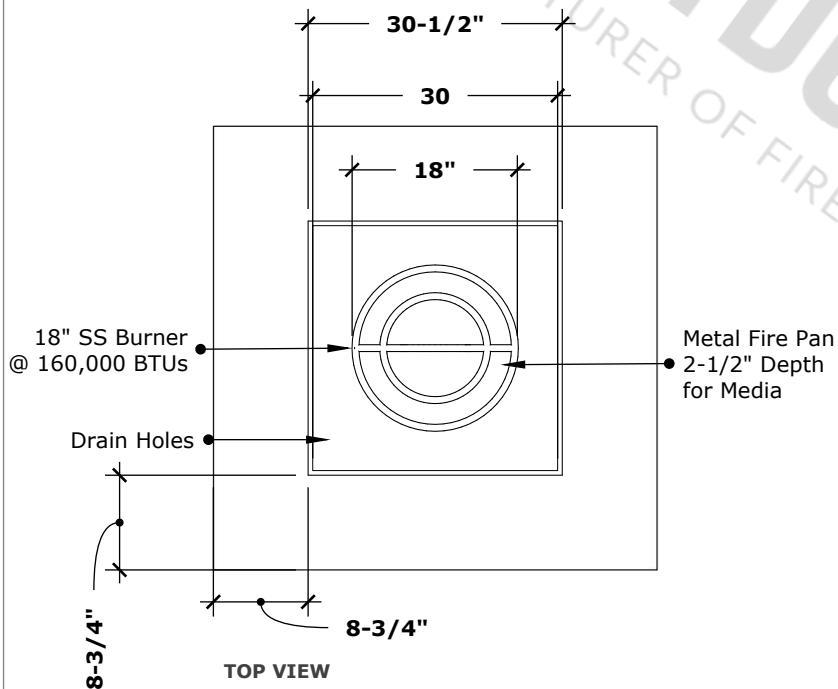

**TOP VIEW**

scale: 1/2" = 1'-0" (1:24)

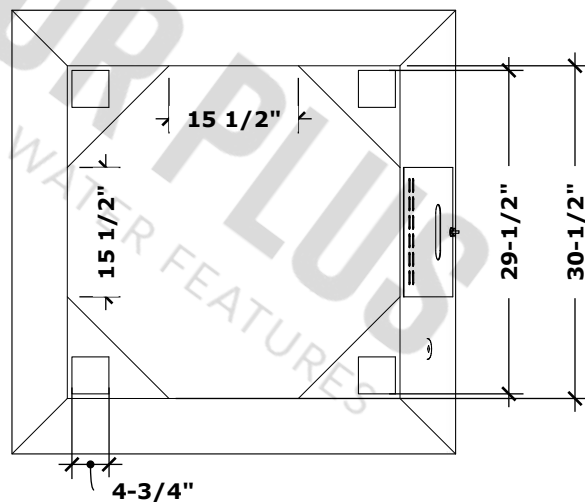

**UNDERSIDE VIEW**

scale: 1/2" = 1'-0" (1:24)

Fire Pit Material: Copper, Powder Coated Steel, Stainless Steel, or Corten Steel

Pan Material: 316 Stainless Steel

Burner Material: 316 Stainless Steel

Gas Type: Liquid Propane (Door Included) or Natural Gas

**Match Lit Unit Includes:** Pan, Burner, Gas Orifice, Gas Hoses, Key Valve, Key, & Lava Chunks.

**110v Ignition Unit Includes:** Pan, Burner, Gas Orifice, Gas Hoses, Key Valve, Key, Plug & Play Electronic Valve, Pilot Igniter.



**110V ELECTRONIC IGNITION CERTIFICATION**  
 ANSI Z21.97-(2017) / CSA 2.41-(2017)

# Mill & Edge | 48" x 32" x 18"

FP-483218



Manufactured By **THE OUTDOOR PLUS**  
USA MANUFACTURER OF FIRE & WATER FEATURES

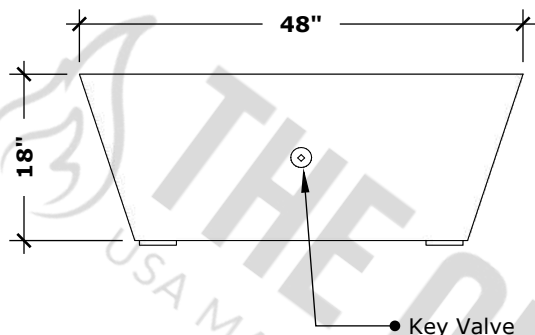

**FRONT VIEW**

scale: 1/2" = 1'-0" (1:24)

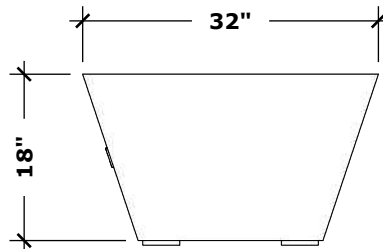

**RIGHT VIEW**

scale: 1/2" = 1'-0" (1:24)

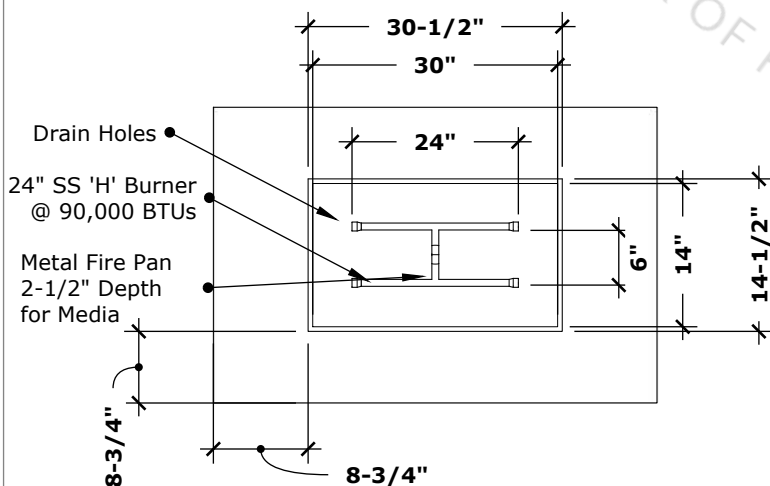

**TOP VIEW**

scale: 1/2" = 1'-0" (1:24)

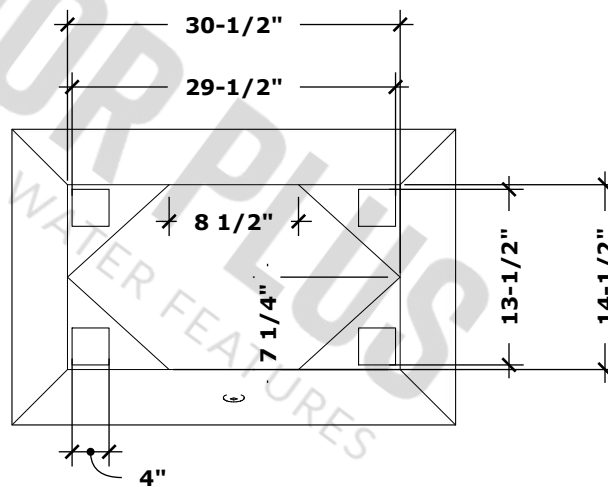

**UNDERSIDE VIEW**

scale: 1/2" = 1'-0" (1:24)

Fire Pit Material: Copper, Powder Coated Steel, Stainless Steel, or Corten Steel

Pan Material: 316 Stainless Steel

Burner Material: 316 Stainless Steel

Gas Type: Liquid Propane or Natural Gas

**Match Lit Unit Includes:** Pan, Burner, Gas Orifice, Gas Hoses, Key Valve, Key, & Lava Chunks.

**110v Ignition Unit Includes:** Pan, Burner, Gas Orifice, Gas Hoses, Key Valve, Key, Plug & Play Electronic Valve, Pilot Igniter.



**110V ELECTRONIC IGNITION CERTIFICATION**  
 ANSI Z21.97-(2017) / CSA 2.41-(2017)

# Mill & Edge | 48" x 32" x 24"

FP-483222



Manufactured By **THE OUTDOOR PLUS**  
USA MANUFACTURER OF FIRE & WATER FEATURES

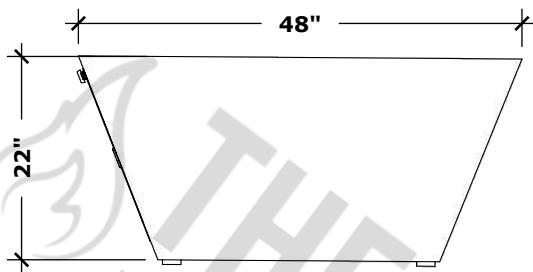

**FRONT VIEW**

scale: 1/2" = 1'-0" (1:24)

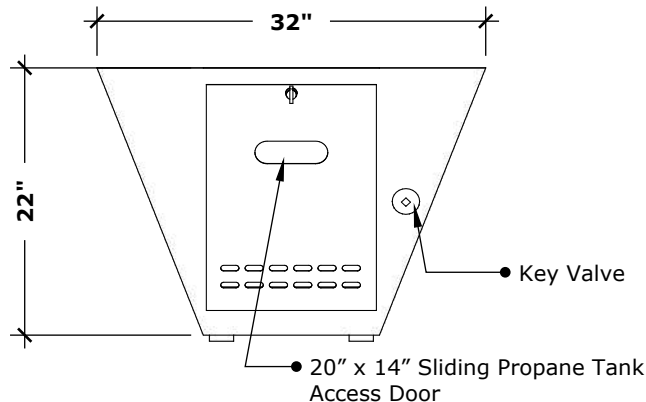

**RIGHT VIEW**

scale: 1/2" = 1'-0" (1:24)

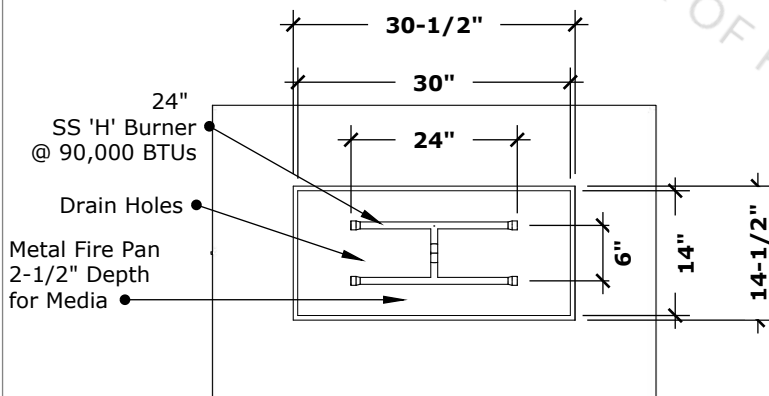

**TOP VIEW**

scale: 1/2" = 1'-0" (1:24)

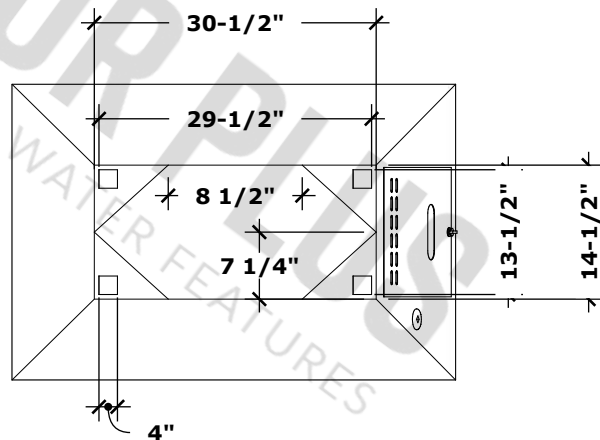

**UNDERSIDE VIEW**

scale: 1/2" = 1'-0" (1:24)

Fire Pit Material: Copper, Powder Coated Steel, Stainless Steel, or Corten Steel

Pan Material: 316 Stainless Steel

Burner Material: 316 Stainless Steel

Gas Type: Liquid Propane (Door Included) or Natural Gas

**Match Lit Unit Includes:** Pan, Burner, Gas Orifice, Gas Hoses, Key Valve, Key, & Lava Chunks.

**110v Ignition Unit Includes:** Pan, Burner, Gas Orifice, Gas Hoses, Key Valve, Key, Plug & Play Electronic Valve, Pilot Igniter.



**110V ELECTRONIC IGNITION CERTIFICATION**  
 ANSI Z21.97-(2017) / CSA 2.41-(2017)

# Mill & Edge | 60" x 32" x 18"

FP-603218



Manufactured By **THE OUTDOOR PLUS**  
USA MANUFACTURER OF FIRE & WATER FEATURES

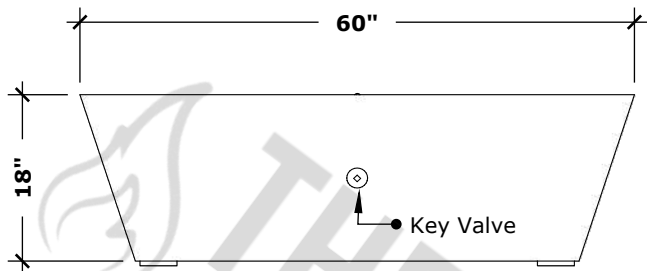

**FRONT VIEW**

scale: 1/2" = 1'-0" (1:24)

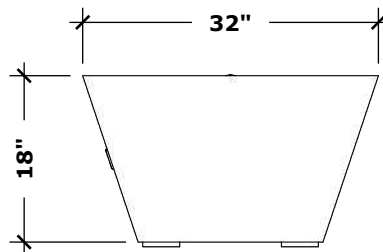

**RIGHT VIEW**

scale: 1/2" = 1'-0" (1:24)

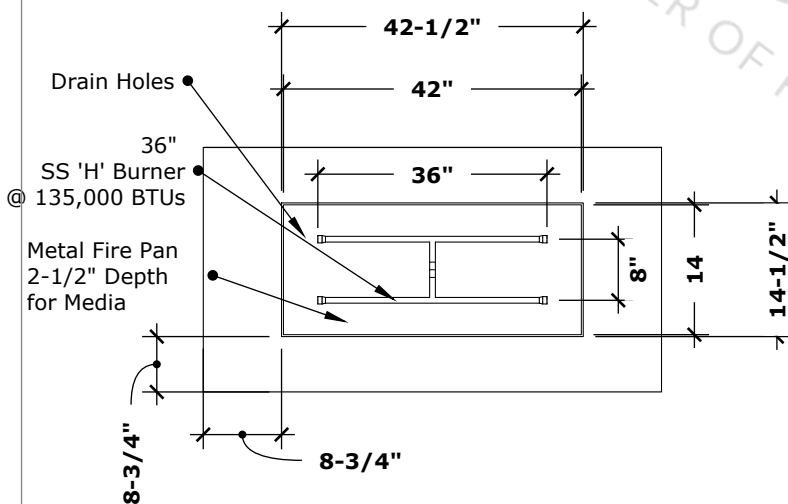

**TOP VIEW**

scale: 1/2" = 1'-0" (1:24)

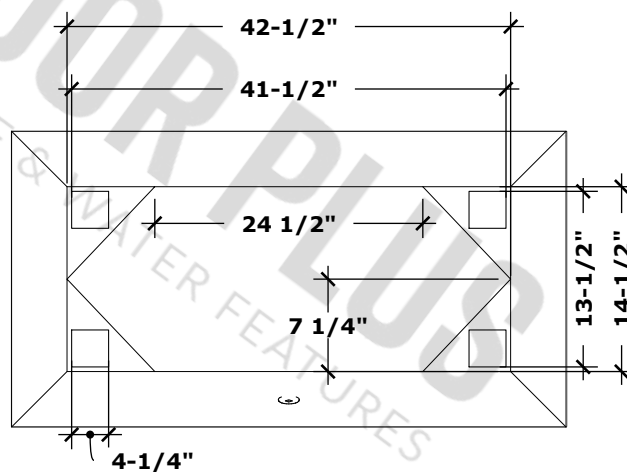

**UNDERSIDE VIEW**

scale: 1/2" = 1'-0" (1:24)

Fire Pit Material: Copper, Powder Coated Steel, Stainless Steel, or Corten Steel  
 Pan Material: 316 Stainless Steel  
 Burner Material: 316 Stainless Steel  
 Gas Type: Liquid Propane or Natural Gas

**Match Lit Unit Includes:** Pan, Burner, Gas Orifice, Gas Hoses, Key Valve, Key, & Lava Chunks.

**110v Ignition Unit Includes:** Pan, Burner, Gas Orifice, Gas Hoses, Key Valve, Key, Plug & Play Electronic Valve, Pilot Igniter.



**110V ELECTRONIC IGNITION CERTIFICATION**  
 ANSI Z21.97-(2017) / CSA 2.41-(2017)

# Mill & Edge | 60" x 32" x 24"

FP-603222



Manufactured By **THE OUTDOOR PLUS**  
USA MANUFACTURER OF FIRE & WATER FEATURES

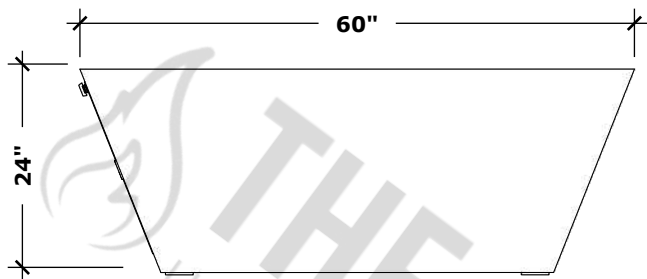

**FRONT VIEW**

scale: 1/2" = 1'-0" (1:24)

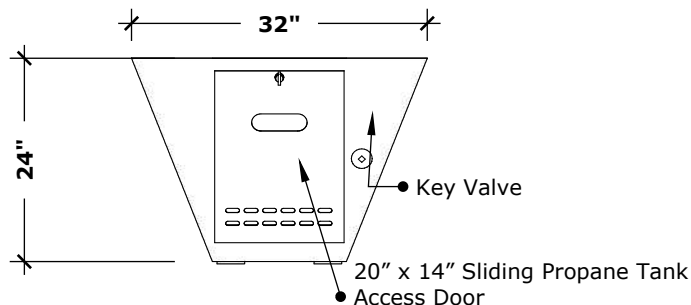

**RIGHT VIEW**

scale: 1/2" = 1'-0" (1:24)

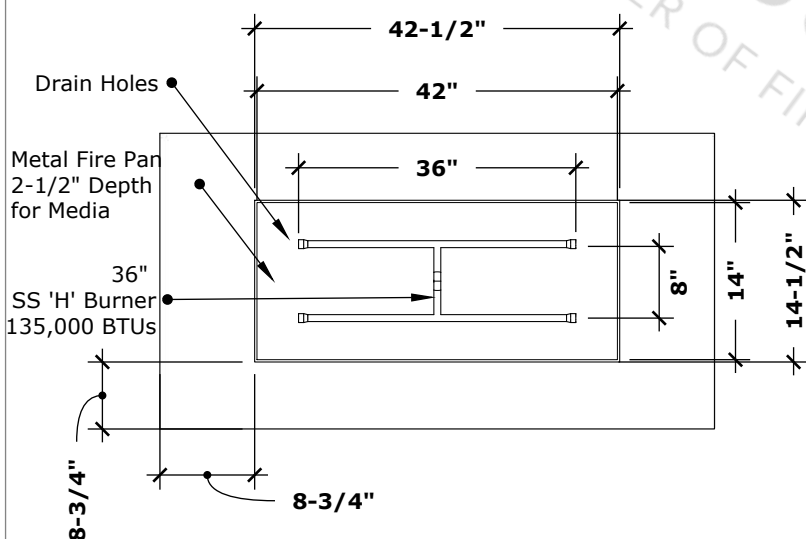

**TOP VIEW**

scale: 1/2" = 1'-0" (1:24)

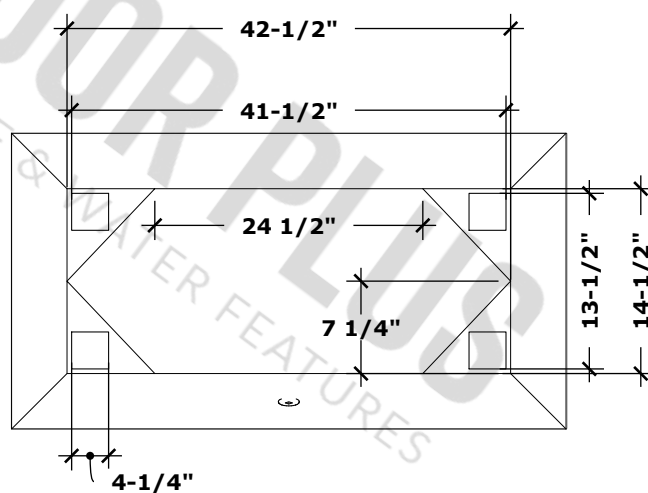

**UNDERSIDE VIEW**

scale: 1/2" = 1'-0" (1:24)

Fire Pit Material: Copper, Powder Coated Steel, Stainless Steel, or Corten Steel

Pan Material: 316 Stainless Steel

Burner Material: 316 Stainless Steel

Gas Type: Liquid Propane (Door Included) or Natural Gas

**Match Lit Unit Includes:** Pan, Burner, Gas Orifice, Gas Hoses, Key Valve, Key, & Lava Chunks.

**110v Ignition Unit Includes:** Pan, Burner, Gas Orifice, Gas Hoses, Key Valve, Key, Plug & Play Electronic Valve, Pilot Igniter.



**110V ELECTRONIC IGNITION CERTIFICATION**  
 ANSI Z21.97-(2017) / CSA 2.41-(2017)



# Mill & Edge | 72" x 38" x 18"

FP-724018



Manufactured By **THE OUTDOOR PLUS**  
USA MANUFACTURER OF FIRE & WATER FEATURES

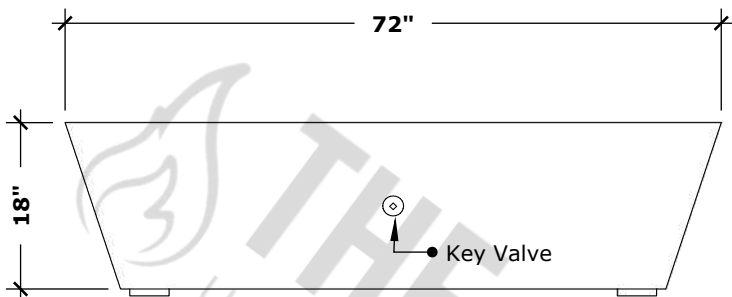

**FRONT VIEW**

scale: 1/2" = 1'-0" (1:24)

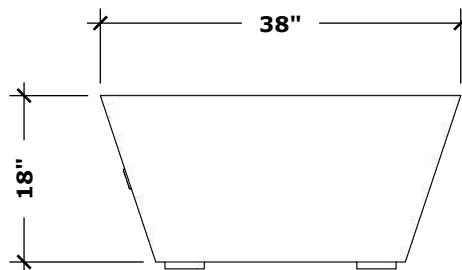

**RIGHT VIEW**

scale: 1/2" = 1'-0" (1:24)

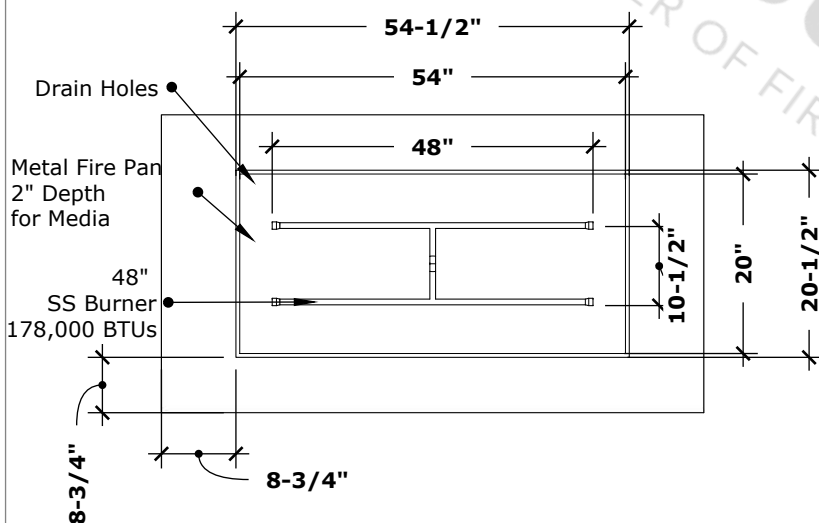

**TOP VIEW**

scale: 1/2" = 1'-0" (1:24)

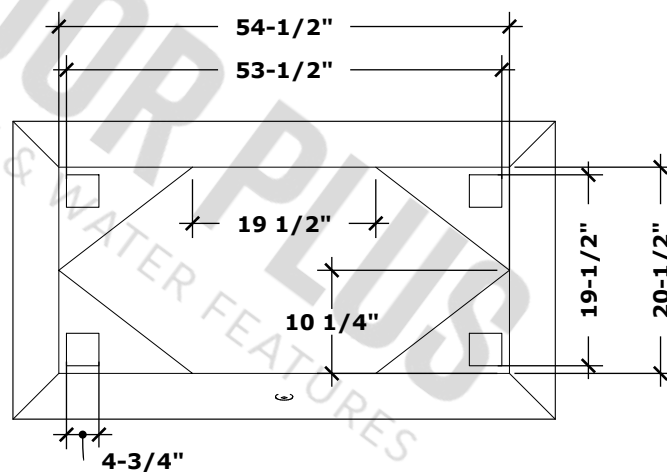

**UNDERSIDE VIEW**

scale: 1/2" = 1'-0" (1:24)

Fire Pit Material: Copper, Powder Coated Steel, Stainless Steel, or Corten Steel  
 Pan Material: 316 Stainless Steel  
 Burner Material: 316 Stainless Steel  
 Gas Type: Liquid Propane or Natural Gas

**Match Lit Unit Includes:** Pan, Burner, Gas Orifice, Gas Hoses, Key Valve, Key, & Lava Chunks.

**110v Ignition Unit Includes:** Pan, Burner, Gas Orifice, Gas Hoses, Key Valve, Key, Plug & Play Electronic Valve, Pilot Igniter.



**110V ELECTRONIC IGNITION CERTIFICATION**  
 ANSI Z21.97-(2017) / CSA 2.41-(2017)

**Mill & Edge | 72" x 38" x 24"**  
**FP-724022**



Manufactured By **THE OUTDOOR PLUS**  
USA MANUFACTURER OF FIRE & WATER FEATURES

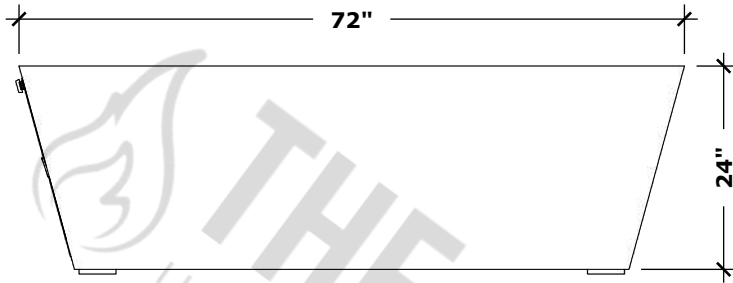

**FRONT VIEW**

scale: 1/2" = 1'-0" (1:24)

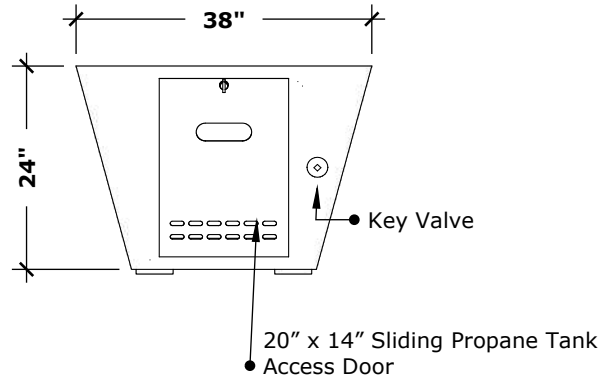

**RIGHT VIEW**

scale: 1/2" = 1'-0" (1:24)

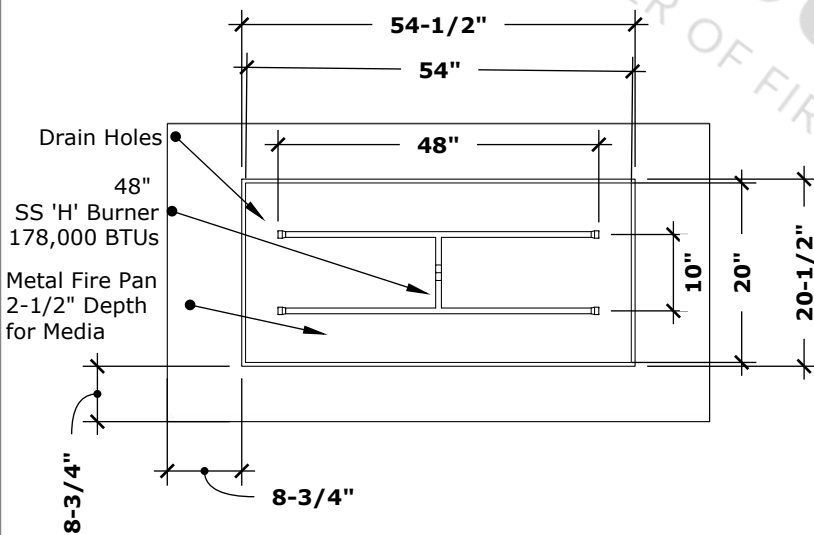

**TOP VIEW**

scale: 1/2" = 1'-0" (1:24)

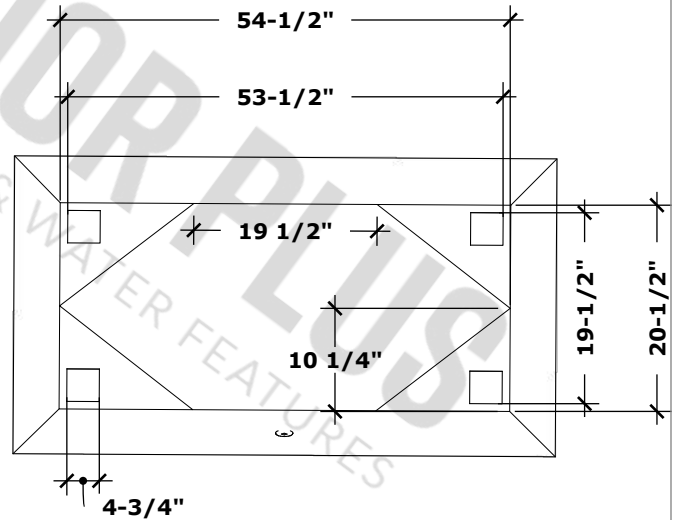

**UNDERSIDE VIEW**

scale: 1/2" = 1'-0" (1:24)

Fire Pit Material: Copper, Powder Coated Steel, Stainless Steel, or Corten Steel  
 Pan Material: 316 Stainless Steel  
 Burner Material: 316 Stainless Steel  
 Gas Type: Liquid Propane (Door Included) or Natural Gas

**Match Lit Unit Includes:** Pan, Burner, Gas Orifice, Gas Hoses, Key Valve, Key, & Lava Chunks.

**110v Ignition Unit Includes:** Pan, Burner, Gas Orifice, Gas Hoses, Key Valve, Key, Plug & Play Electronic Valve, Pilot Igniter.



**110V ELECTRONIC IGNITION CERTIFICATION**  
 ANSI Z21.97-(2017) / CSA 2.41-(2017)

**Sliding Access Door** | Door: 20" x 14"  
 Sliding Tray: 14" x 14" x 2"

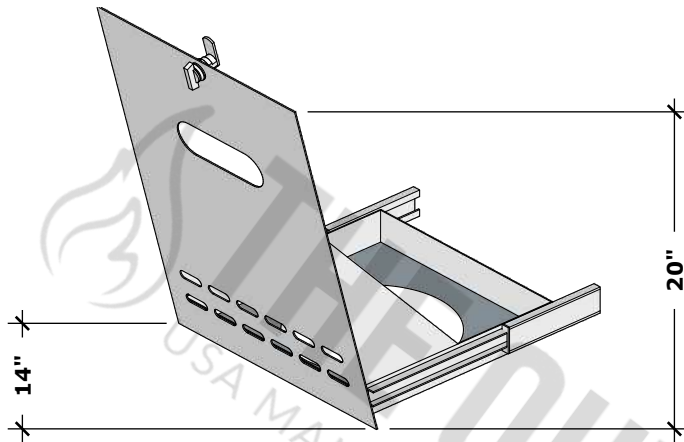

**FRONT VIEW**

scale: 1/2" = 1'-0" (1:24)

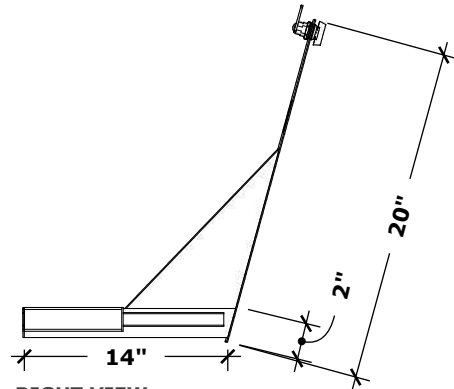

**RIGHT VIEW**

scale: 1/2" = 1'-0" (1:24)

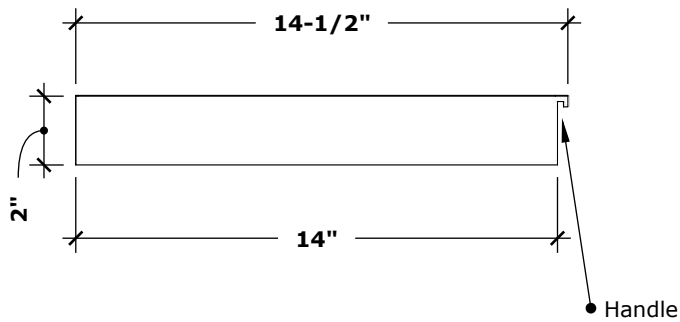

**TOP VIEW**

scale: 1/2" = 1'-0" (1:24)

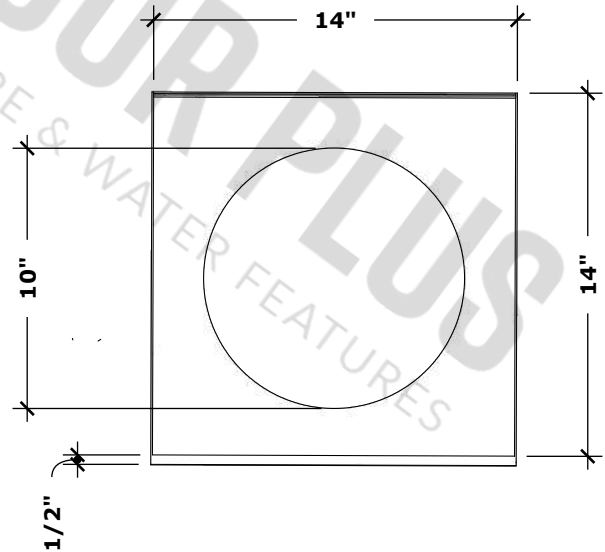

**UNDERSIDE VIEW**

scale: 1/2" = 1'-0" (1:24)

Access Door Material: Copper, Powder Coated Steel, Stainless Steel, or Corten Steel

Access Door Includes: Door with Latch & Sliding drawer



**110V ELECTRONIC IGNITION CERTIFICATION**  
 ANSI Z21.97-(2017) / CSA 2.41-(2017)