

4

3

2

1

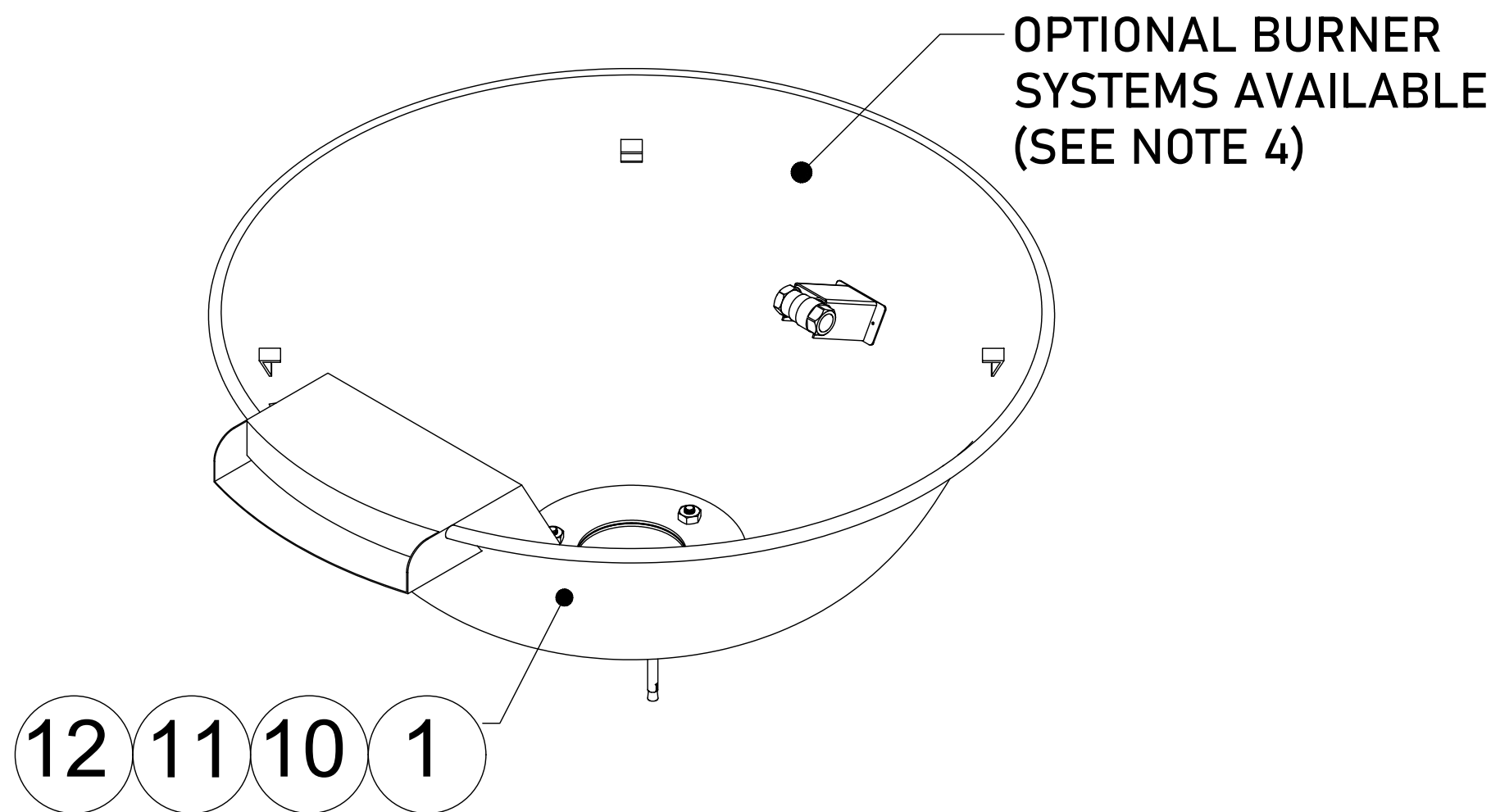

REVERSE PERSPECTIVE VIEW (LID OPENED)

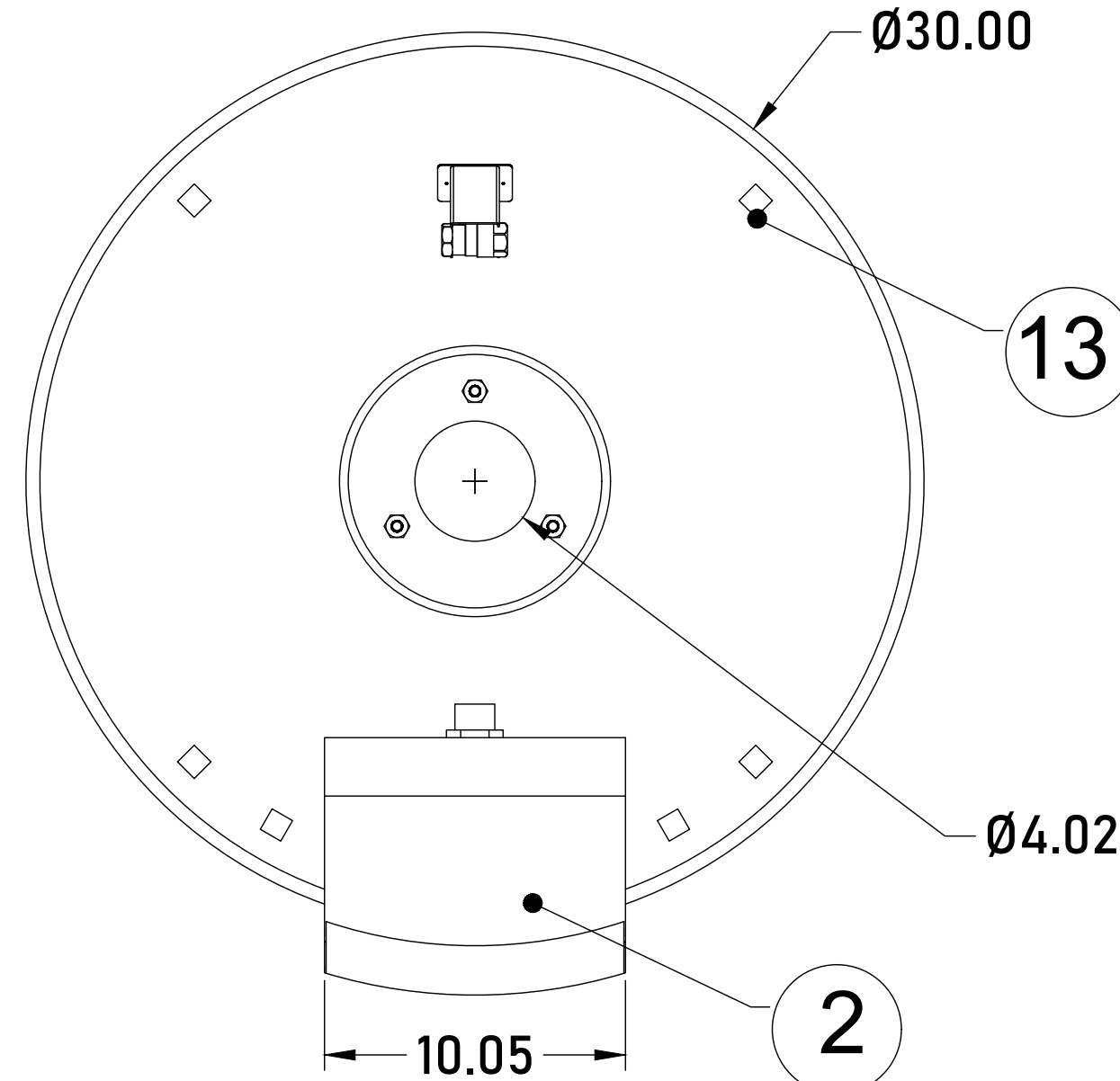

TOP VIEW



PERSPECTIVE VIEW

NOTES:

1. ALL DIMENSIONS ARE IN INCHES UNLESS OTHERWISE SPECIFIED.
2. MATERIAL: 20 OUNCE COPPER FINISHED WITH MACHINED HAMMER TEXTURE
3. UNIT WEIGHT: ____ LBS
4. IGNITION: ELECTRONIC IGNITION, MANUAL SPARK IGNITION, MATCH LIT IGNITION
5. SOME ITEMS ARE NOT SHOWN IN DRAWING VIEWS. SEE BILL OF MATERIALS FOR FULL PARTS LIST.

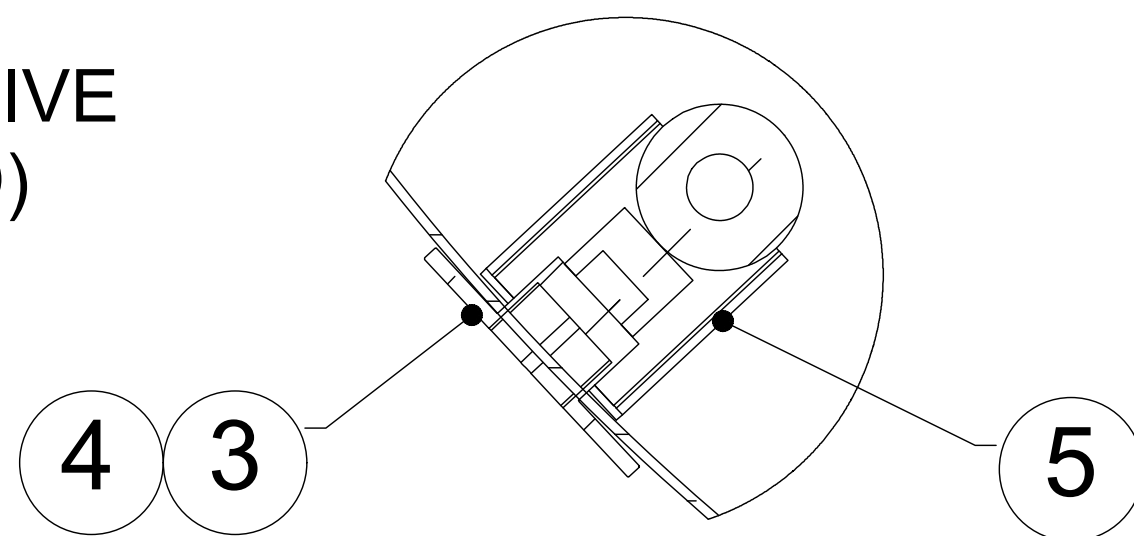

DETAIL C SCALE 1:4

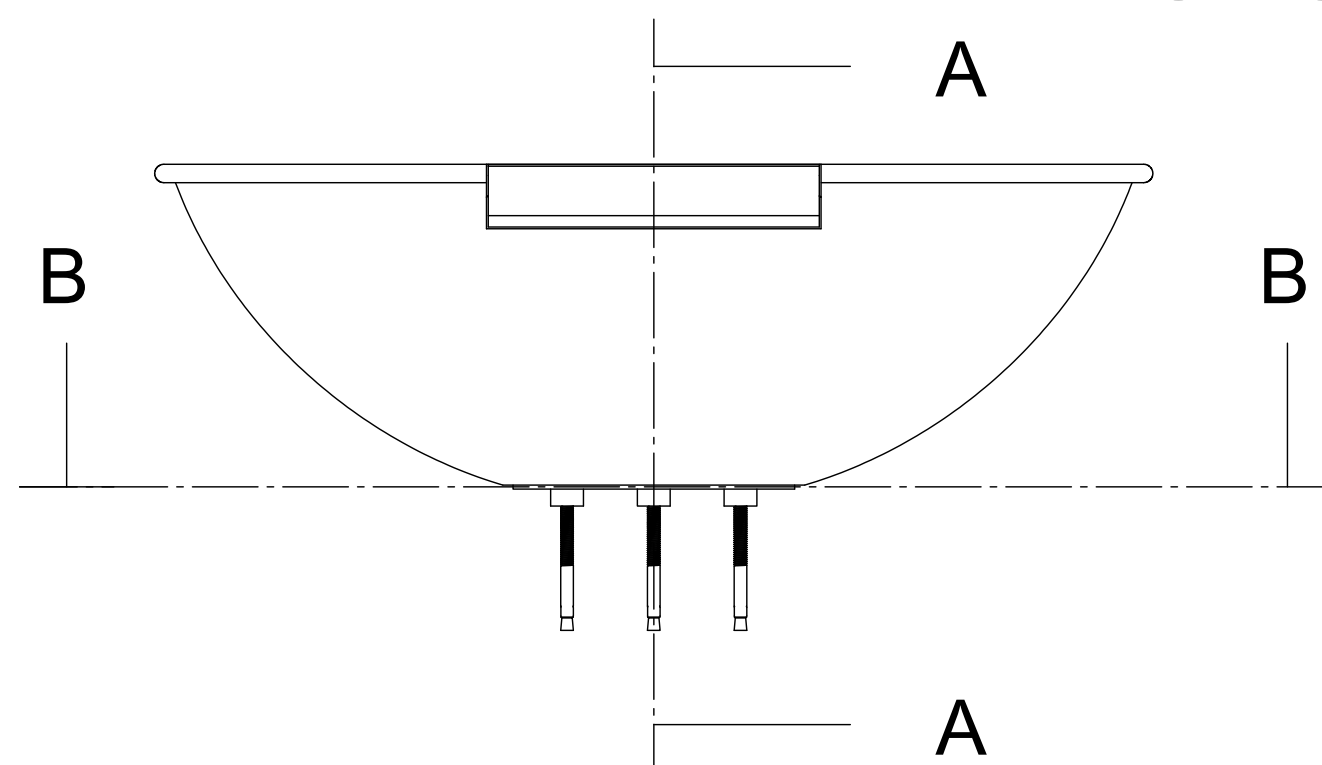

FRONT VIEW

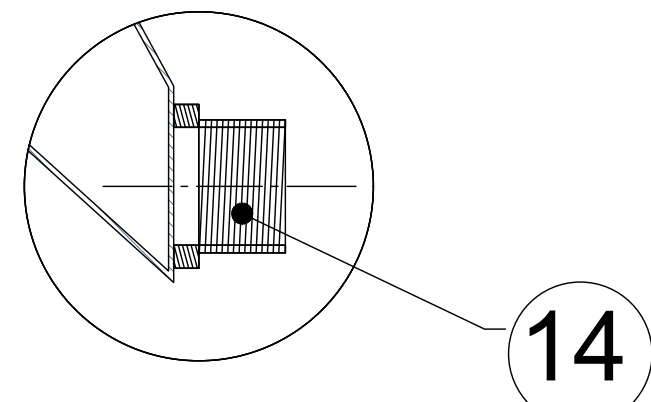

DETAIL E SCALE 1:2

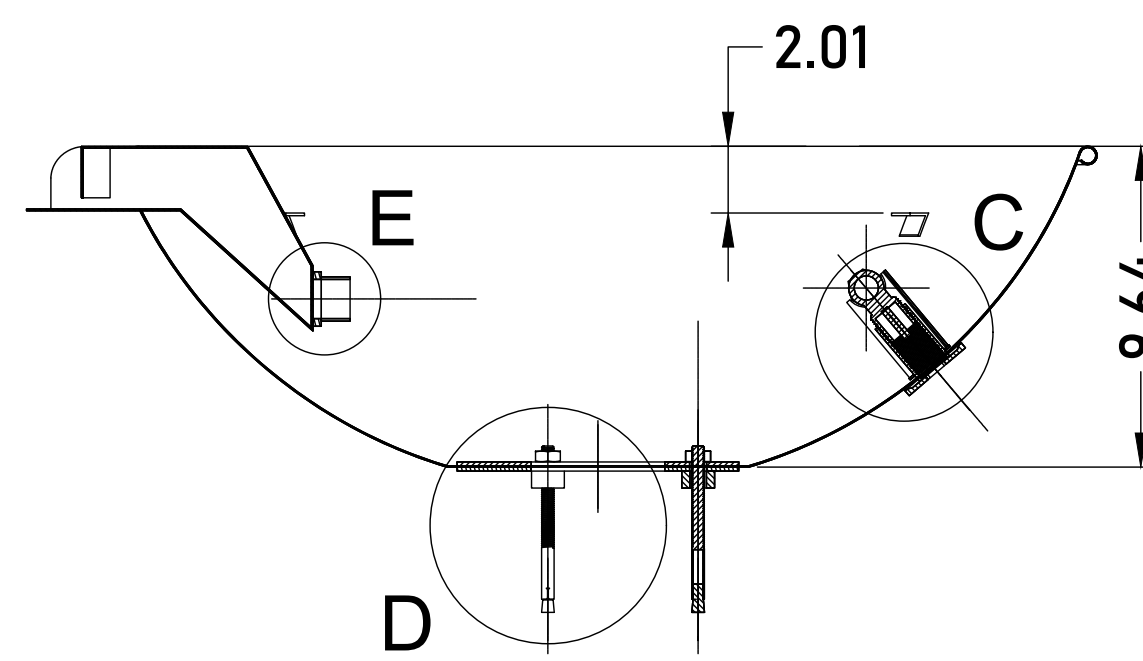

SECTION A-A

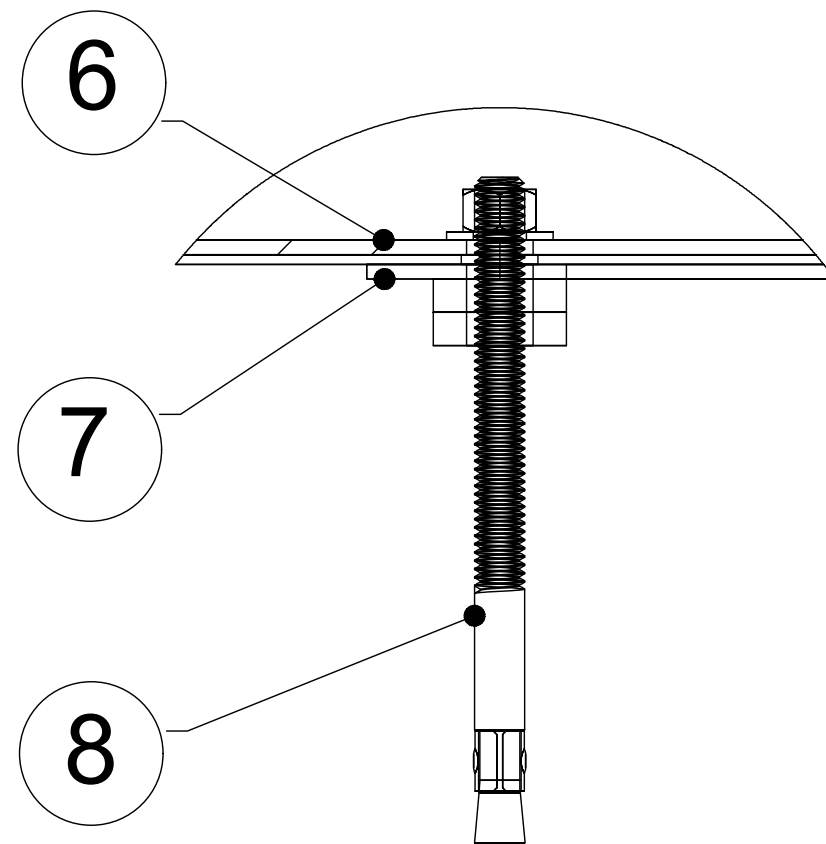

FOR CONCRETE DECKS

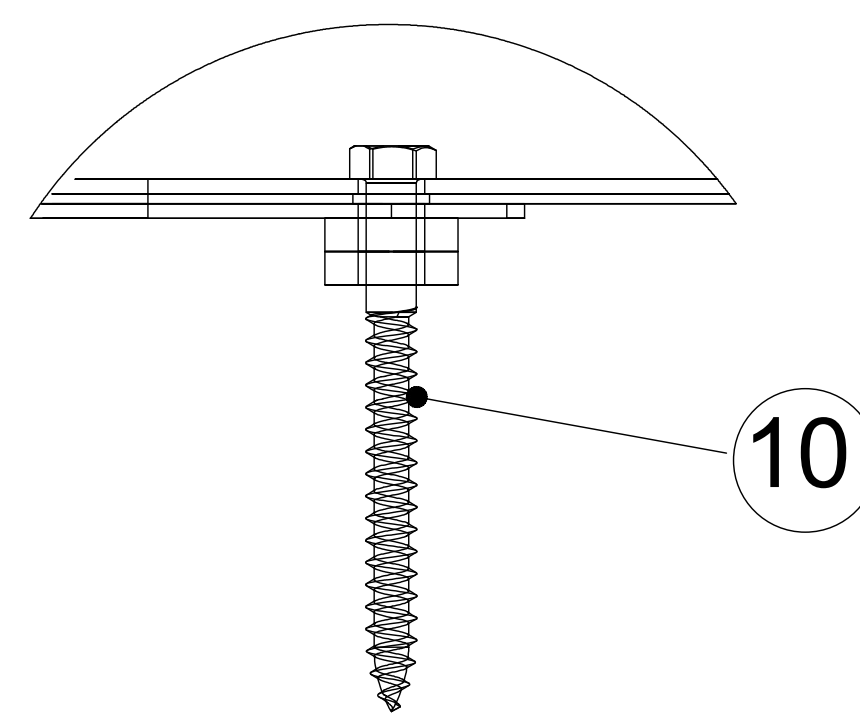

FOR WOOD DECKS

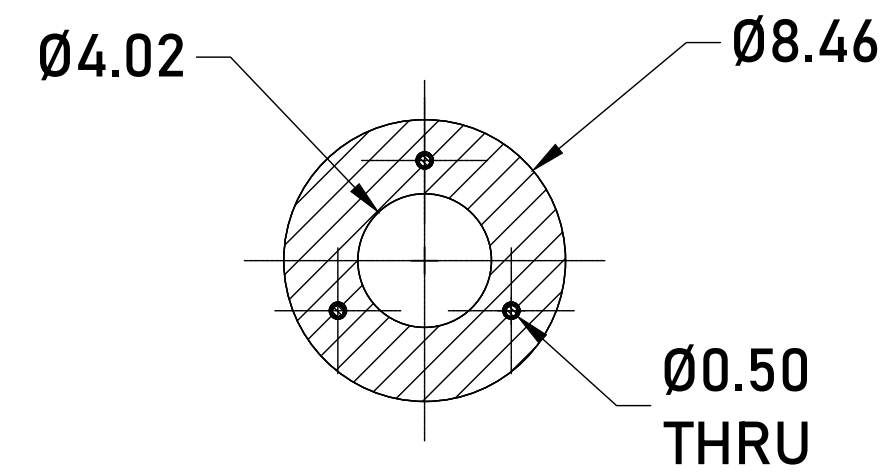

FRONT PRINT SECTION B-B

ITEM NO.	QTY.	PART NUMBER	DESCRIPTION
14	1	-	1" MNPT BRASS CNNCT, WATER CONNECTION
13	4	-	PAN HOLDER FEET
12	2	-	END COMPRESSION FITTING ADAPTER, 1/2" FIP X 5/8" FLARE
11	2	-	END COMPRESSION FITTING ADAPTER, 1/2" MIP X 5/8" FLARE
10	2	-	TRANQUILINE WHISTLE FREE FLEX LINE - 5/8" OD (1/2" ID)
9	3	-	WOOD ANCHOR (LAG SCREW), 3/8" X 4" LONG
8	3	-	CONCRETE ANCHOR, 3/8" X 5" LONG
7	1	-	STARFIRE DESIGNS, MOUNTING BRACKET
6	1	-	TRANQUILINE WHISTLE FREE FLEX LINE - 5/8" OD (1/2" ID)
5	1	-	KEY VALVE BRACKET
4	1	-	STARFIRE DESIGNS 3" UNIVERSAL KEY & VALVE FLANGE COMBO, FINISH: ANTIQUE COPPER
3	1	-	STARFIRE DESIGNS 1/2" MANUAL STRAIGHT QUARTER TURN GAS KEY VALVE
2	1	MORENO-TAZA-30RES	TAZA MORENO FW RESERVOIR
1	1	MORENO-TAZA-FW-309	FIRE PIT ENCLOSURE, TAZA MORENO

PROPRIETARY AND CONFIDENTIAL

THE INFORMATION CONTAINED IN THIS DRAWING IS THE SOLE PROPERTY OF STARFIRE DIRECT. ANY REPRODUCTION IN PART OR AS A WHOLE WITHOUT THE WRITTEN PERMISSION OF STARFIRE DIRECT IS PROHIBITED.

DETAIL D SCALE 1:4

UNLESS OTHERWISE SPECIFIED:		NAME	DATE	
DIMENSIONS ARE IN INCHES	DRAWN			
TOLERANCES:				
FRACTIONAL: ±1/8"		CHECKED		
ANGULAR: MACH ± BEND ±		ENG APPR.		
TWO PLACE DECIMAL ±	MFG APPR.			
THREE PLACE DECIMAL ±	Q.A.			
INTERPRET GEOMETRIC TOLERANCING PER:				
MATERIAL				
FINISH				
NEXT ASSY	USED ON	TAZA MORENO FIRE PIT FIRE/WATER 30" X 9"		
APPLICATION	DO NOT SCALE DRAWING	SIZE B DWG. NO. MORENO-TAZA-FW-309 REV A	SCALE: 1/12 WEIGHT: SHEET 1 OF 1	

4

3

2

1