

JCP.201

Centerpost Push-Up



IMPORTANT:

Please read this entire manual before installing or operating your umbrella.

DIAGRAM & PARTS LIST

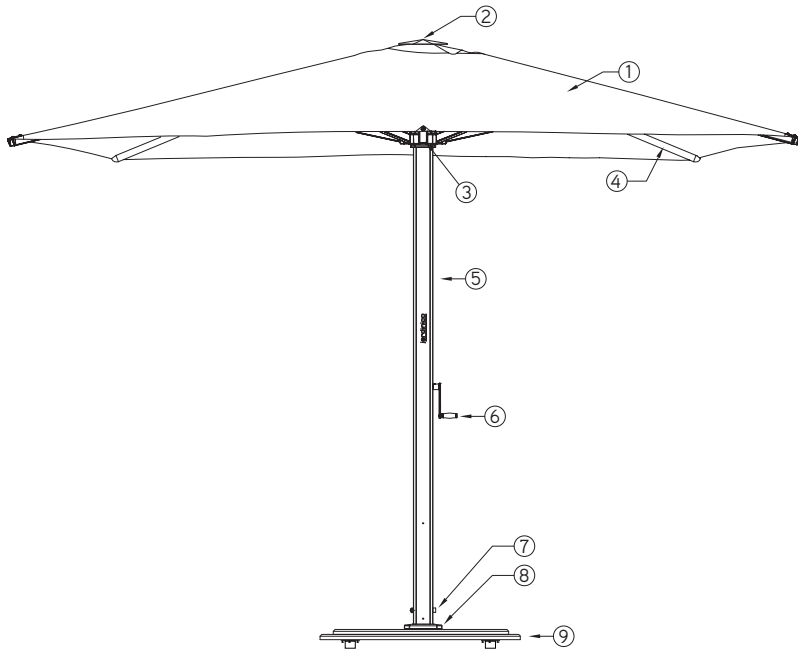

- | | |
|-----------------|--|
| 1. Canopy | 7. Release Screw |
| 2. Finial | 8. Internal Mast Stem Cover |
| 3. Hub | 9. JCB201 Base with Wheels (sold separately) |
| 4. Rib | 10. Strap (not shown) |
| 5. Center Pole | 11. Protective Cover (not shown) |
| 6. Crank Handle | |

SPECIFICATIONS

15 ft (4.5m)		8.30 ft (2.53m)	11.94 ft (3.64m)	n/a	n/a	n/a

WARRANTY:

Jardinico Caractère manufactures all its shade styles from the finest aluminum alloys to ensure the strength, durability, and integrity of each and every style. We pride ourselves as a totally vertical operation. This means that we manufacture and produce over 90% of the components used in our products from the raw state. We can monitor every stage of the manufacturing process and maintain a consistent level of quality.

Our only business and focus is shade and shade type products. Our goal is that each and every Jardinico Caractère style will exceed your expectations.

Our **Limited Warranty** is outlined below. **NOTE: Wind damage is not covered under any manufacturer's warranty.**

5 Year Limited Warranty includes the mast, boom, head fitting, elbow, center pole, top and bottom hub, rust and corrosion on base, and stainless steel hardware only. If there is damage under the warranty, Jardinico Caractère will replace and/or repair any item listed in this category at its discretion. Labor charges are not covered under this limited warranty.

5 Year Limited Warranty covers the Sunbrella® Natté fabrics. Visit www.sunbrella.com/warranty for more details. Labor charges are not covered under this limited warranty.

1 Year Limited Warranty covers the wheels and powder coat finish on all bases. If the powder coat finish flakes, bubbles, peels or loses color; Jardinico Caractère will re-finish or replace the defective base at its discretion. Normal wear and tear is not covered under this limited warranty. Labor charges are not covered under this limited warranty.

Exclusions: Wind damage, acts of nature (such as, but not limited to, freezing or any type of extreme weather). Failures caused by abusive use and normal wear and tear are not covered under this warranty.

Caution: Seaside and indoor pool use, salt & chlorides can accumulate on the powder coat finish, leading to finish failure. Failure or neglect to make needed cleanings may cause paint to blister, and such failure will void limited warranty.

Those filing warranty claims will be responsible for all shipping, handling, and freight charges on all claims to Jardinico Caractère in Baldwin Park, CA. All warranty claims must be submitted with the original proof of purchase, date of purchase, name of dealer, and the description of the damage. The Jardinico Caractère warranty is not transferable. Jardinico Caractère reserves the right to repair, replace, and/or redesign any product that is returned under a warranty claim.

It is our policy to continuously improve designs, materials and manufacturing methods in order to provide you with the finest products. Therefore, variations in specifications, materials, prices, styles and finishes may be made without notice.

For questions, contact Customer Service: 626-338-8810 or info@jardinicousa.com

MAINTENANCE :

MAINTAINING THE JARDINICO CARACTÈRE FRAME AND FITTINGS

1. Hose mast and frame with water periodically, more often if installation is in a salty or industrial environment.
2. Inspect the installation fittings, mount bolts, rib spacers, etc. on a regular basis and tighten if necessary.
3. Seaside and indoor pool use: Due to demands of both of these environments, Jardinico Caractère recommends weekly or biweekly cleaning with mild soap and water to remove the concentrated deposits and protect the powder coat finish.

MAINTAINING THE JARDINICO CARACTÈRE CANOPY FABRIC

1. Clean up spills and stains right away. Spills can be removed by using a clean absorbent cloth.
2. For general maintenance, use a soft brush to remove dust and dry soil. Wash down with clean, warm water (i.e., garden hose) every so often to avoid dirt becoming ingrained. Allow the fabric to air dry before closing the canopy.
3. If a thorough cleaning is necessary, sponge over the fabric using a mild soap solution (2% solution). Rinse well with plenty of water to remove all soap residue.
4. Never use detergents, cleaning fluids or solvents.
5. Please visit the fabric websites for more details: www.jardinico-caractere.com or www.sunbrella.com
6. Use protective canopy cover during storage or when not in use.

GENERAL GUIDELINES

1. Jardinico Caractère highly recommends that no umbrella, regardless of size or weight, ever be left unattended in the open position. In windy conditions, it is further recommended that umbrellas be closed, removed from their base, and stored, or laid horizontally. This will reduce the risk of damage to your umbrella, furniture, and other belongings or property. To ensure stability of your umbrella, please observe proper placement, and use sufficient weight (base). This catalog contains minimum recommendations for necessary weight; but this can vary, depending on the conditions in your particular area.
2. NOTE: Wind damage (or any damage caused by acts of nature) is not covered under warranty.
3. Sufficient base weight must be used to secure umbrellas at all times. Please see individual product pages for recommended minimum weight requirements for free-standing applications.

ASSEMBLY INSTRUCTIONS

Two-person team is recommended for assembly

Installing Internal Stem

1. Lay umbrella on soft clean surface. Attach finial to canopy structure.
2. Remove release screw and washer with supplied wrenches from bottom of center pole and set aside. Remove internal stem from bottom of center pole.
3. Install internal stem onto steel base with supplied 4 bolts and tighten using allen wrench. NOTE: Do not use power drill. May cause damage to base.
4. Slide internal mast stem cover over internal stem.

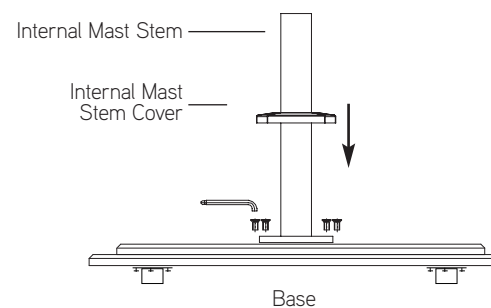
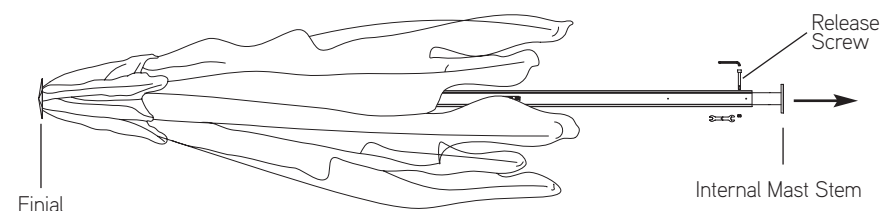

5. Using a two-person team, carefully lift umbrella and insert bottom of center pole onto internal mast stem.
6. Turn center pole to line up internal mast stem hole with center pole holes. Re-attached release screw and washer with supplied wrenches.

You are now ready to operate your umbrella!

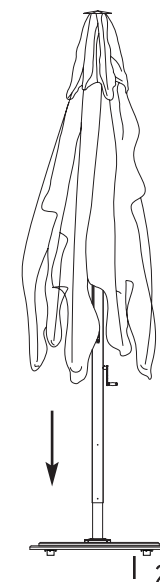

OPERATING INSTRUCTIONS

Remove all packaging from umbrella.

To Open Canopy

1. Remove the strap that holds the canopy structure to center pole when in the closed position. Take note of the “parachute” folding method used to fold the canopy when closed. (See page 4 to properly fold canopy.)
2. Slightly loosen arms. **CAUTION: NEVER FORCE THE ARMS.** If you experience any resistance, make sure all arms are freed manually to facilitate opening.
3. Insert crank handle into socket on center pole and crank handle clockwise until canopy is completely open.



To Close Canopy

1. Turn crank handle counter clockwise until canopy is completely closed.



To Properly Fold Canopy

The 100% solution dyed canopy will last longer if you fold it as it was packed and shipped. This technique is similar to the way a parachute is folded and is especially important when folding the canopy for seasonal storage or when left in the closed position for an extended period of time.

Using this technique at all times will significantly extend the life of the canopy.

1. When the canopy has been fully closed, stand in front of the canopy structure and begin the folding process by pulling out two panels opposite the center pole.
2. Once rolled tight, pull adjacent panels out one at a time and fold to the center, alternating sides until all the panels have been pulled out from the arms and folded into the center.
3. Wrap provided strap around canopy to secure.
4. When not in use, cover umbrella with provided protective cover.

