

Aspen



Assembly, Operation, & Maintenance
Instructions

Please read before opening and operating umbrella

A

Included Items for Assembly

(A) - Upper Umbrella Assembly (Includes Upper Pole)

(B) - Lower Pole Assembly

(C) - 1/4" - 20 x 2.0" Socket Head Cap Screws

(D) - 1/4" - 20 x 1.75" Socket Head Cap Screws

(E) - 1/4" - 20 Socket Insert Nuts

(F) - Cord Control Lever

(G) - 3/16" Allen Wrench

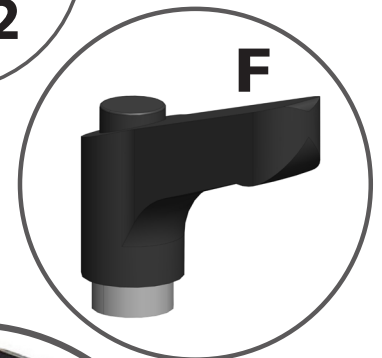
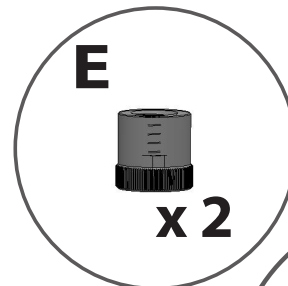
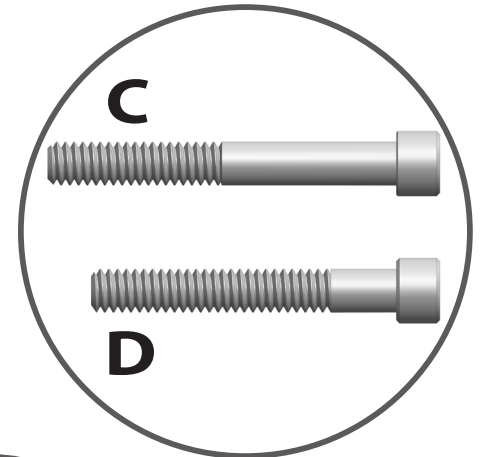

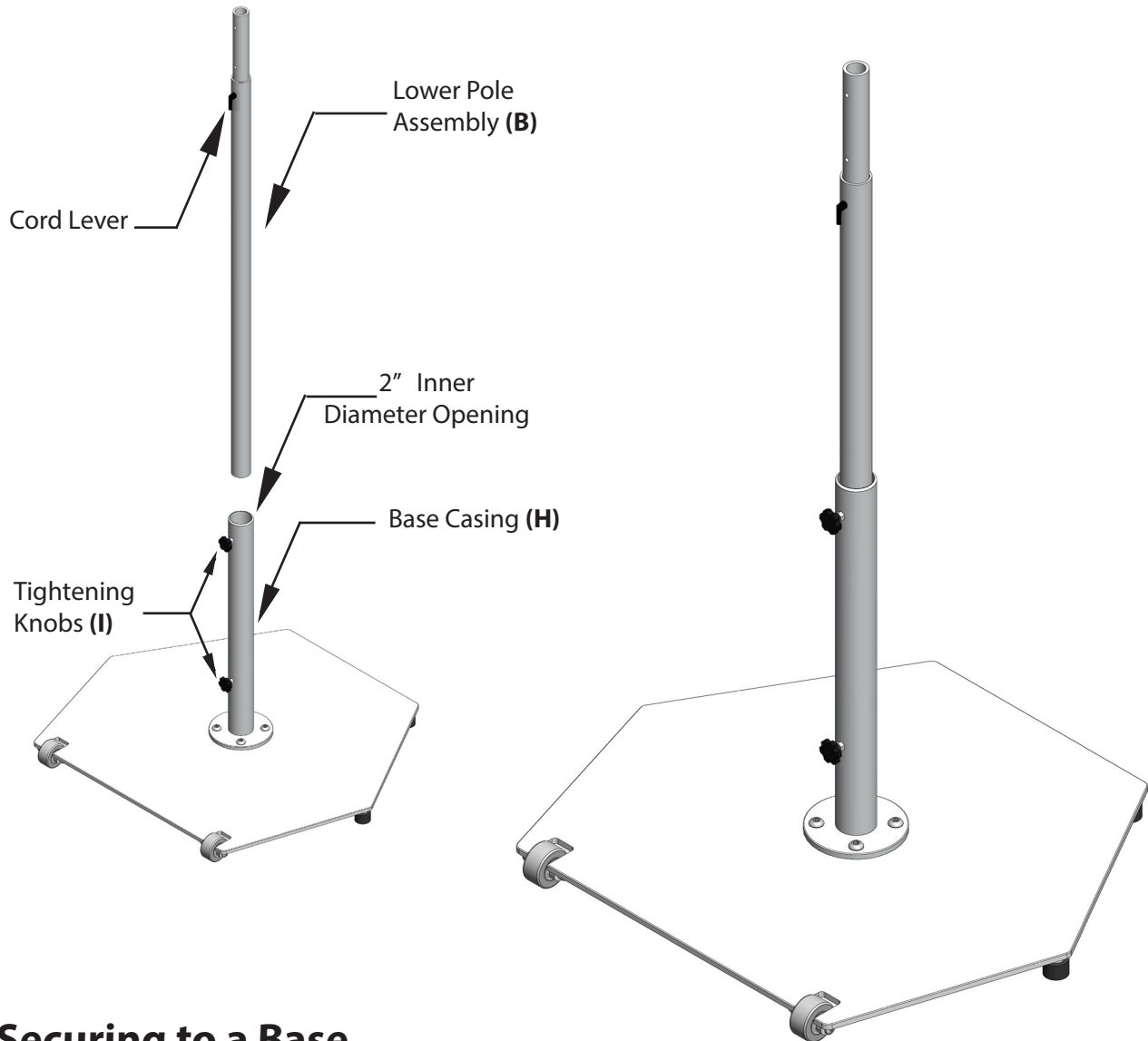

2. Securing to a Base

- i. Insert lower pole assembly (B) into base casing (H).
- ii. If placing umbrella in table, ensure table opening is clear and ground base is properly situated below.
- iii. Insert lower pole assembly through table opening and into ground base casing.
- iv. Tighten available knobs (I) until pole is secure.

 **Warning:** Wind can cause the umbrella to fall over or fly away, resulting in property damage and personal injury. Always secure the umbrella to a base having enough weight and resistance to anchor the umbrella. Always close the umbrella in moderate to high winds and when not attended.

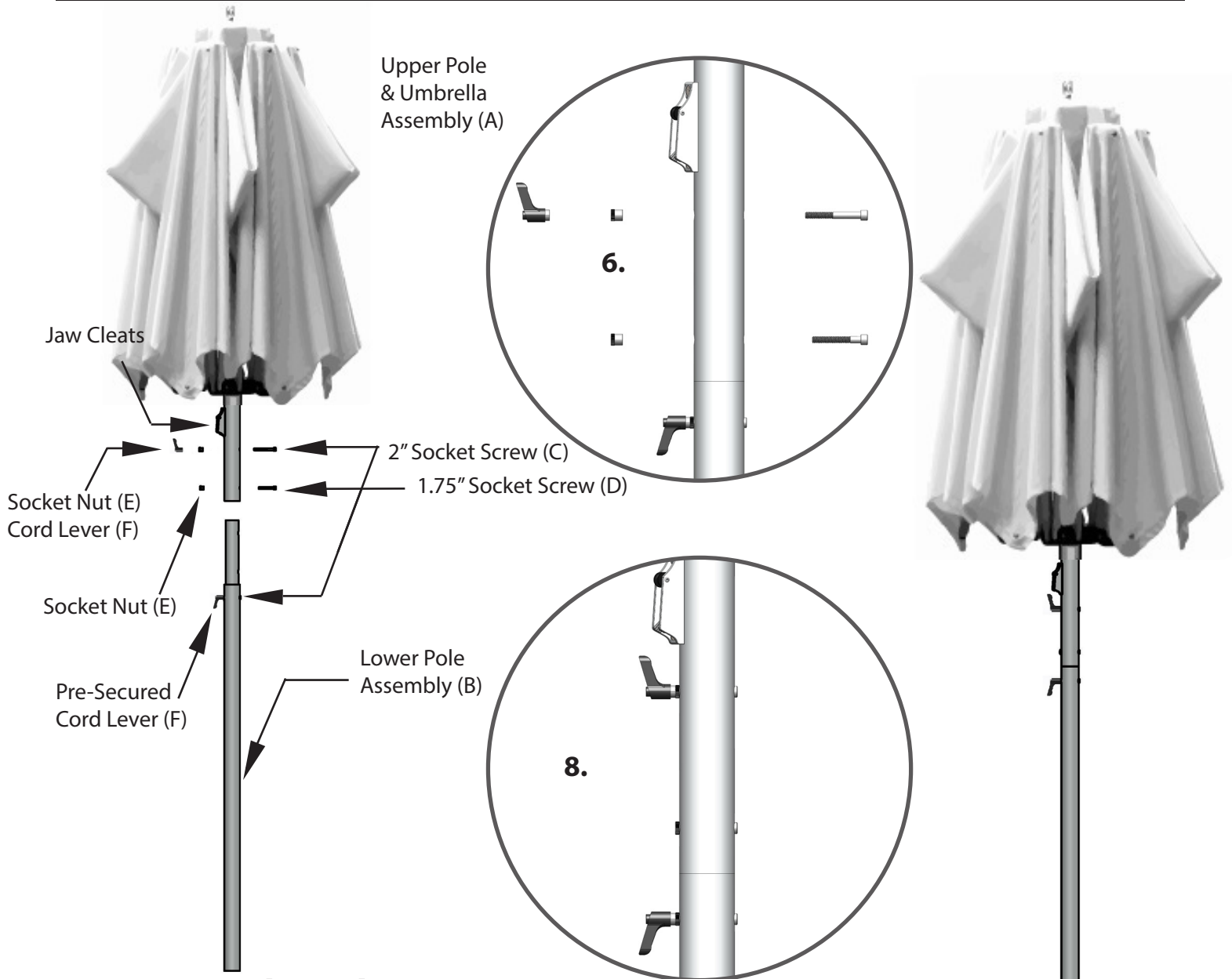

3. Securing the Splice

- i. Ensure lower pole section (B) is securely anchored in base. (Page 3)
- ii. Lift upper umbrella assembly (A) and settle onto reduced end of lower pole assembly (B).
- iii. Align the jaw cleats on the same side as the lower pole's pre-secured cord lever (F). Rotate upper pole (A) to align holes in upper pole with holes in lower pole.
- iv. Insert longer socket screw (C) into upper hole, from opposite side of the jaw cleats.
- v. Insert shorter socket screw (D) into lower hole, from opposite side of jaw cleats.
- vi. Attach socket nuts (E) to end of socket screws (C & D).
- vii. Tighten both socket screws with provided allen wrench (G) to secure upper and lower pole.
- viii. On upper socket screw end, attach cord lever (F) and tighten. Splice complete.

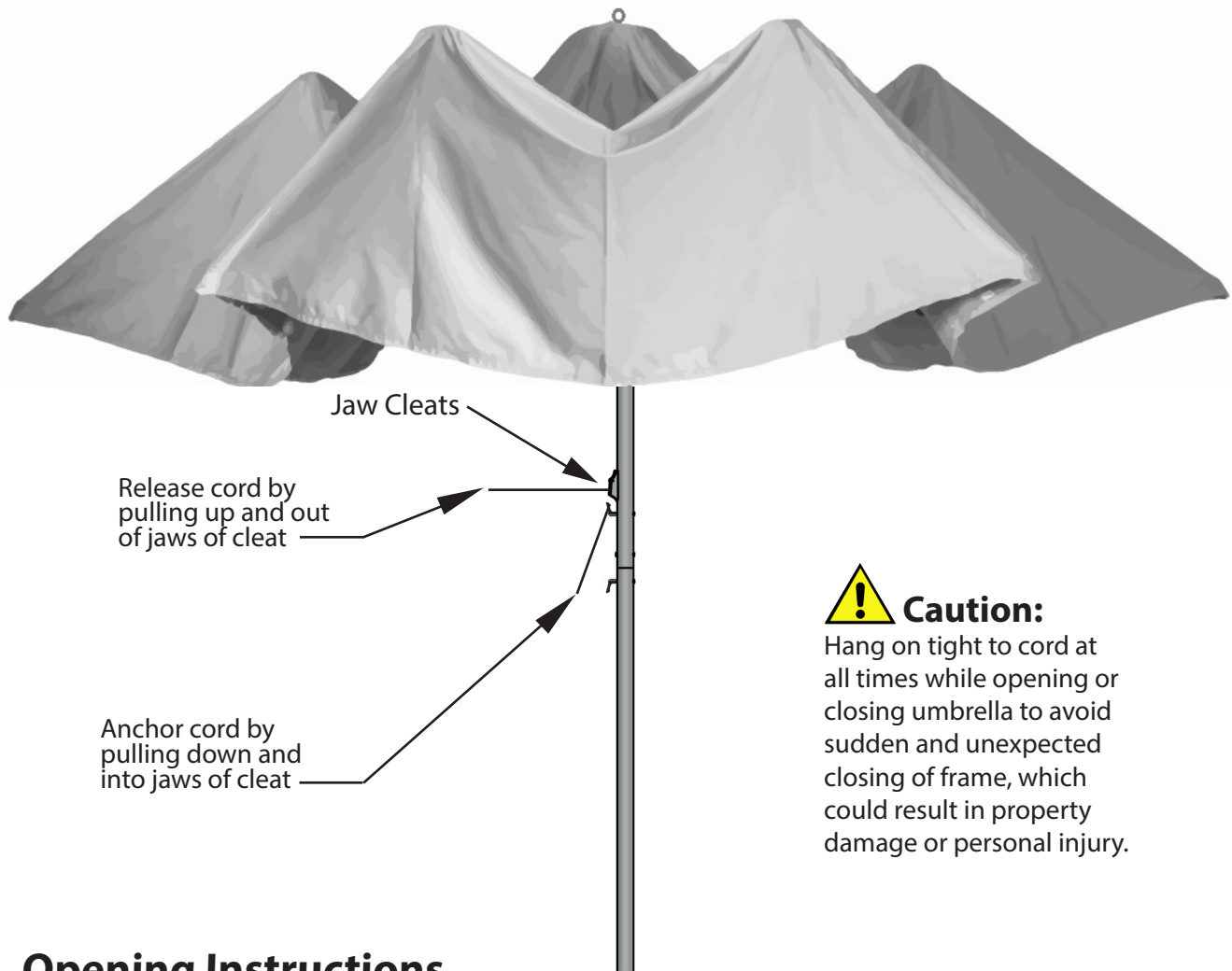

Caution:

Hang on tight to cord at all times while opening or closing umbrella to avoid sudden and unexpected closing of frame, which could result in property damage or personal injury.

4a. Opening Instructions

- i. Prior to opening, always ensure the umbrella is properly secured to an adequate anchor.
- ii. Release cord from jaws of cleats by pulling upward.
- iii. Open umbrella by pulling cord away from cleats (remain seated or walk backward to avoid ribs as they expand).
- iv. Secure cord by pulling downward into jaws of cleats.
- v. Wrap extra cord around cord levers.

4b. Closing Instructions

- i. Push button on one cord lever, and turn lever 180 degrees.
- ii. Pull cord off levers.
- iii. Release cord from jaws of cleats by pulling upward.
- iv. Close umbrella slowly by releasing cord, straightening cord as necessary to prevent twists. Be careful not to lose grip of cord at any time. (Remain seated or walk forward to avoid contracting ribs).



Warning: The cord on this umbrella can present a strangulation hazard. Keep children away.

5a. Securing the Optional Pin

- i. Once the umbrella is fully open, insert the hanging lock pin (K) into the provided hole.
- ii. To close, hold tight to cord and pull forcefully on ring, removing lock pin (K) from column.

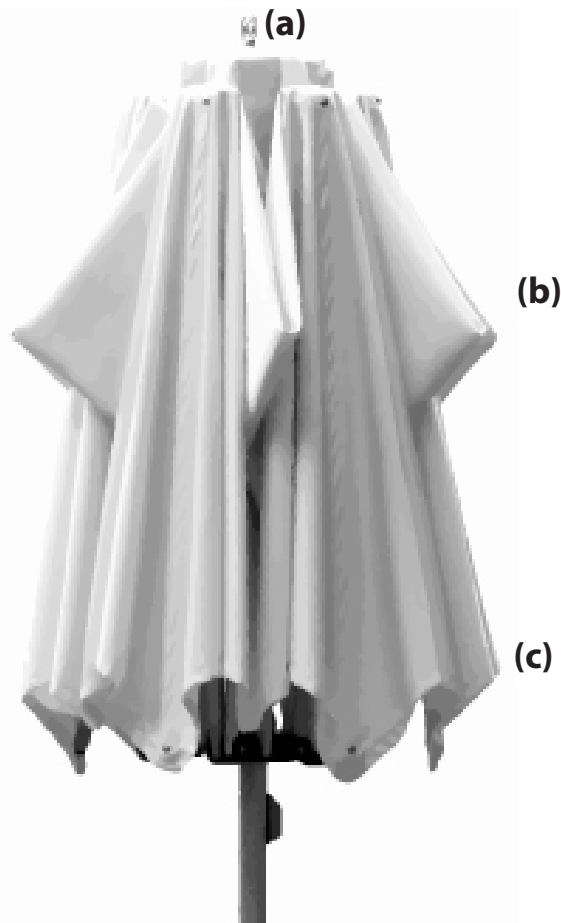
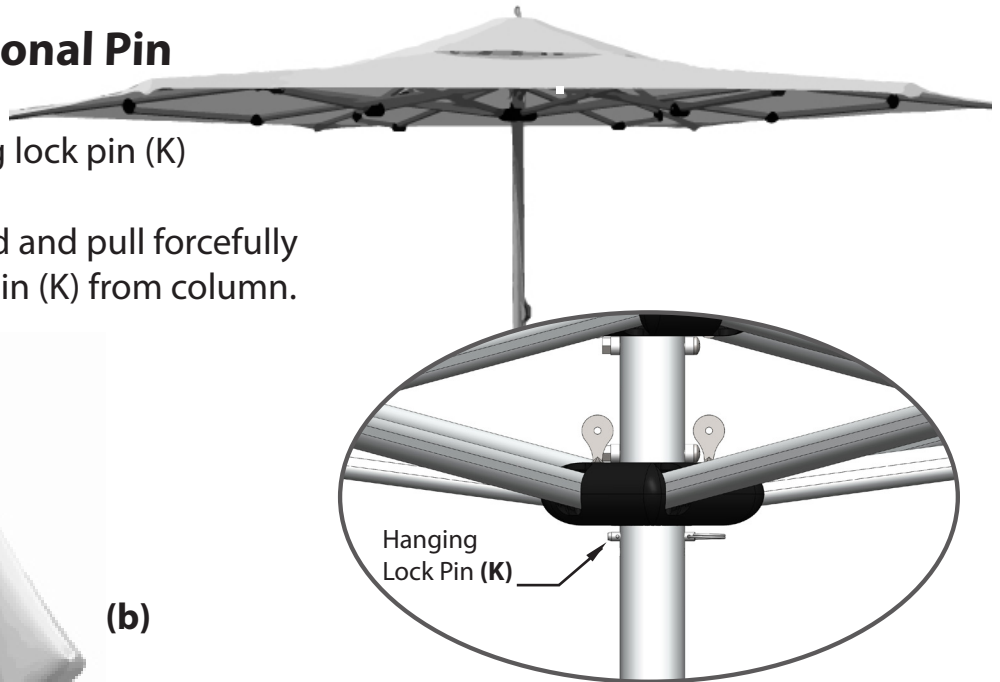

5b. Using the Tie Cord

The canopy design allows for drainage and air ventilation when closed. Tie the cord low around the canopy to prevent flapping and allow water to drain through the upper portion of the canopy when not being used.

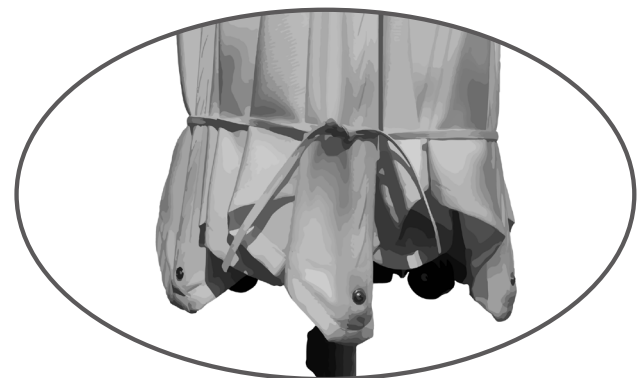

5c. Storing the Umbrella

Before storing the umbrella, ensure the pleats and folds have been smoothed.

- i. Pull the draping pockets (b) out to a 90 degree corner.
- ii. Smooth skirt hems (c) so that fabric hangs flat and is absent of wrinkles.
- iii. If using a cover, tie provided cord around pockets (b) so that they are pressed in place against the umbrella, then secure cover.
- iv. Store horizontal with the pole flat on the ground or hung from a ceiling using the functional finial (a).
- v. Never seal umbrella; always allow for air flow to prevent moisture buildup.

Your satisfaction is our number one priority. ARTiculatedshade umbrellas are designed to be structurally sound, deliberately functional, and aesthetically unique. We source all materials from US companies focusing on durability and weather resistance. Proper use and care is critical to prolonging the longevity and functionality of all ARTiculatedshade products. We strongly recommend the following:

- * Prior to use, always ensure the umbrella is properly secured to an adequate anchor.
- * Never force the umbrella to open.
- * Hang on tight to cord at all times while opening or closing umbrella to avoid sudden and unexpected closing of frame.
- * If it is too windy for you to enjoy your patio, it is too windy for your umbrella to be open. The Apsen has been successfully tested to 40 mph wind loads, however base size and local conditions may not merit the same results. As such, please adhere to the following guidelines:
 - * As winds strengthen or gusts increase, close the umbrella.
 - * Always close the umbrella when unattended.
 - * In anticipation of and during severe weather conditions, store the umbrella out of harm's way to prevent damage.
- * Articulatedshade recommends routine inspection of frame and hardware. Loose fasteners should be tightened and any broken elements replaced immediately to prevent further damage to the umbrella.
- * If operating in marine or industrial environments, the canopy and frame should be rinsed off with fresh water monthly to remove salt and particle accumulation.
- * Canopy should be cleaned regularly. Hand wash with mild soap, lukewarm water, and a soft bristle brush. Always allow to air dry. For stubborn stains or a more thorough machine washing, follow Glen Raven's guide for Sunbrella fabrics: www.sunbrella.com/en-us/how-to-clean/clean-sunbrella-shade-fabrics.
- * Do not use a pressure washer to clean canopies.
- * The canopy was designed with self draining vents to avoid a build up of water when not in use. Regularly check the folds to ensure proper ventilation and drainage.
- * Check base and base hardware routinely, and tighten as necessary.
- * Do not operate rolling bases on stairways or steep inclines.
- * See base manufacturer's instructions for care and use.

1. Limited Warranty; Warranty Period. Subject to the exclusions and other limitations set forth below, ARTiculatedshade, LLC. (“We” or “Us”) warrants to the original end-user (“You”) that (a) **the frame (including the mast, ribs, plastic hubs and connectors, pulleys, cleats, fasteners, and cord)** (the “Frame”) of the ARTiculatedshade, LLC Compact Patio Umbrella manufactured by Us will be free from material defects in both material and workmanship (the “Frame Limited Warranty”) **for a period of five years after Your purchase of the Frame** (the “Frame Warranty Period”) and (b) **the canopy** (the “Canopy” and together with the Frame, the “Product”) of the ARTiculatedshade, LLC Compact Patio Umbrella manufactured by Us will be free from material defects in both material and workmanship (the “Canopy Limited Warranty” and together with the Frame Limited Warranty, the “Limited Warranty”) **for a period of three years after Your purchase of the Canopy** (the “Canopy Warranty Period” and together with the Frame Warranty Period, the “Warranty Periods”). THE LIMITED WARRANTY IS MADE IN LIEU OF ALL OTHER GUARANTEES AND/OR WARRANTIES, EXPRESS OR STATUTORY AND IS GIVEN ONLY TO YOU AND IS NOT TRANSFERABLE TO ANY THIRD PARTY. ALL IMPLIED WARRANTIES, INCLUDING THE IMPLIED WARRANTIES OF MERCHANTABILITY AND FITNESS FOR A PARTICULAR PURPOSE APPLICABLE TO (i) THE CANOPY ARE LIMITED IN DURATION TO THE CANOPY WARRANTY PERIOD OR (ii) THE FRAME ARE LIMITED IN DURATION TO THE FRAME WARRANTY PERIOD. This Limited Warranty gives You specific legal rights, and You may also have other rights that vary from State to State.

2. Limitations on the Warranty.

The Limited Warranty DOES NOT cover

- (a) any cosmetic damage, including exposed parts of the Product that are scratched or damaged, fading, or variations in color,
- (b) non-material damage that does not directly influence shade production of the Product or safety, or
- (c) any defects caused by
 - (i) normal wear and tear;
 - (ii) abuse, neglect, tampering, or misuse of the Product;
 - (iii) any accident, act of God (**including wind**), or other event occurring beyond Our reasonable control or after Your purchase of the Product (including but not limited to corrosion and other effects of natural contaminants at a location where the Product has been located);
 - (iv) misapplication, overloading, or improper installation;
 - (v) improper operation, maintenance, repair, handling, transport, storage, or environmental conditions;
 - (vi) Product alteration in any manner by anyone other than Us;
 - (vii) shipping; or
 - (viii) falling over of the Product due to any of the foregoing (i) - (vii).

The presence of such limitations shall be determined by Us in Our sole discretion.

3. Remedies and Limitations. If the Product does not comply with the Limited Warranty during the applicable Warranty Period, (a) You shall submit to Us within 10 days after Your discovery of such non-compliance a written claim meeting the requirements set forth below (a “Warranty Claim”), and (b) Your sole and exclusive remedy is that We will, at Our option, either (i) replace the applicable Product or the defective part of the applicable Product or (ii) repair the applicable Product or the defective part of the applicable Product, in each case, within a reasonable time after Your submission of the Warranty Claim. We shall, at Our option, use new or refurbished parts for replacement. YOUR SOLE AND EXCLUSIVE REMEDY, AND OUR SOLE AND EXCLUSIVE LIABILITY, FOR NON-COMPLIANCE WITH THE LIMITED WARRANTY IS AS SET FORTH IN THIS PARAGRAPH. WE SHALL NOT BE LIABLE FOR ANY LOSS OF USE, LOSS OF PROFITS, OR LOSS OR DAMAGE TO YOUR PROPERTY, OR FOR ANY OTHER INCIDENTAL, CONSEQUENTIAL, OR EXEMPLARY DAMAGES THAT MAY ARISE, AND THE TOTAL LIABILITY OF US SHALL NOT EXCEED THE PRICE PAID BY YOU FOR THE PRODUCT. Some States do not allow the exclusion or limitation of incidental or consequential damages, so the above limitations or exclusions may not apply to You.

4. Obligations of Purchaser. To make a Warranty Claim, contact Us by mail or courier at Our principal address of 1089 Gilbert Street, Boulder, Colorado 80302, and in Your Warranty Claim, (a) identify Your name and contact information (including Your phone number, email address, and address where the Product is located), (b) identify the Product by model and serial number, (c) describe with reasonable specificity the alleged non-compliance, (d) identify the date of Your discovery of the non-compliance, and (e) enclose a copy of Your purchase receipt to verify date of purchase and that You are the original end-user. After We contact You regarding Your Warranty Claim, You shall follow the instructions We provide for returning the non-complying Product. At Our request, You shall return any Product or part that is replaced by Us to the location designated by Us, and such Product or part shall become Our property upon such request. (Continued on page 9)

4. **Obligations of Purchaser. (Continued from page 8)**

You are responsible for all of the following if incurred by Us as a result of Your Warranty Claim:

- (i) any labor charges that apply to
 - (A) Our cutting or sewing of the Canopy or
 - (B) the installation of any part, and
- (ii) any shipping and freight charges, and You shall pay all such amounts within 30 days after our delivery of an invoice therefor.

If You would like to speak with Us regarding this Limited Warranty, Our customer service team is available at 303-817-4606 and can be emailed at service@articulatedshade.com from 9:00 a.m. to 5:00 p.m. Mountain Prevailing Time, Monday through Friday except holidays.

5. Assumption of Risk. Your use of the Product for any purpose other than the specified uses stated in the Product instructions is at Your own risk.

6. Governing Law. The Limited Warranty gives You specific legal rights, and You also may have other rights which vary from state to state. The Limited Warranty and the rights and obligations herein are governed by the laws of the State of Colorado, without regard to rules pertaining to conflicts of law. The state courts located in Boulder County, Colorado shall have exclusive jurisdiction for any disputes relating to the Limited Warranty.



Warning: Wind can cause the umbrella to fall over or fly away, resulting in property damage and personal injury. Always secure the umbrella to a base having enough weight and resistance to anchor the umbrella. Always close the umbrella in moderate to high winds and when not attended.



Warning: The cord on this umbrella can present a strangulation hazard. Keep children away.



Caution: Hang on tight to cord at all times while opening or closing umbrella to avoid sudden and unexpected closing of frame, which could result in property damage or personal injury.

ARTiculatedshade, LLC

1089 Gilbert Street
Boulder, Colorado 80302
303.817.4606

For questions, email info@articulatedshade.com.
For warranty claims, email service@articulatedshade.com.