

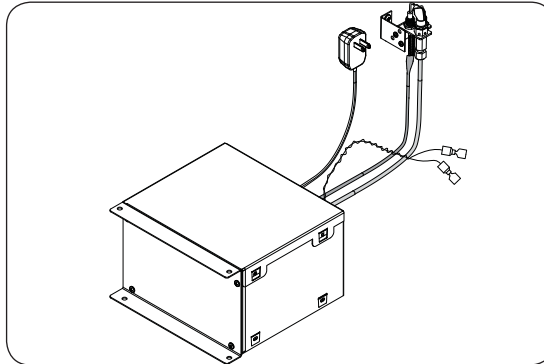

### AUTOMATIC LIGHTING SAFETY PILOT SYSTEM FOR NATURAL OR PROPANE GAS

**Models:**  
**EPK-2M-AD**  
**EPK-2M-AD/LP**



#### FEATURES:

- INTERMITTENT PILOT IGNITION •
- NON-STANDING FLAME-SENSING PILOT •
- MANUAL SWITCH ON/OFF (not included) •
- AC POWER OPERATION •

#### SUITABLE FOR THE FOLLOWING BURNERS:

- P BURNERS •
- PB BURNERS •
- P45 BURNERS •
- G4 SERIES BURNERS •
- G45 SERIES BURNERS •

## EPK-2M-AD PILOT KITS

### WARNING

If the information in this manual is not followed exactly, a fire or explosion may result, causing property damage, personal injury, or loss of life.

Do not store or use gasoline or other flammable vapors and liquids in the vicinity of this or any other appliance.

#### WHAT TO DO IF YOU SMELL GAS:

- Open a window.
- Do not try to light any appliance.
- Do not touch any electrical switch; do not use any phone in the building.
- Immediately call the gas supplier from a neighbor's phone and follow the gas supplier's instructions.
- If you cannot reach the gas supplier, call the fire department.

**Installation and service must be performed by an NFI Certified or other qualified professional installer, service agency, or the gas supplier.**

#### INSTALLER & CONSUMER

These instructions **MUST** be retained with this appliance

**Important:** Read these instructions carefully before starting installation of the burner control system.

The Peterson Real Fyre burner system is to be installed only in a solid-fuel-burning fireplace with a working flue constructed of noncombustible material. Solid fuels shall not be burned in a fireplace where the unit is installed. The installation, including provisions for combustion, ventilation air, and required minimum permanent vent opening, must conform with the *National Fuel Gas Code (ANSI Z223.1/NFPA 54)* and applicable local building codes. In Canada, the installation must conform with the *Natural Gas and Propane Storage and Handling Installation Code (CSA-B-149.1)*. A damper stop clamp is included to maintain the minimum permanent vent opening and to prevent full closure of the damper blade. **The chimney damper must be fixed fully opened when burning the unit. The burner system is designed to burn with yellow flames; thus, adequate ventilation is absolutely necessary.**



# TABLE OF CONTENTS

## GETTING STARTED

|  |   |
|--|---|
| IMPORTANT INFORMATION.....             | 3 |
| ELECTRICAL SAFETY INFORMATION .....    | 4 |
| SPECIFICATIONS.....                    | 4 |
| EPK-2M-AD REPLACEMENT PARTS LIST ..... | 5 |

## INSTALLATION

|   |    |
|---|----|
| INSTALLATION.....                                     | 6  |
| <i>PREPARATION</i> .....                              | 6  |
| <i>CREATE VALVE HOUSING OPENING/FRAME</i> .....       | 6  |
| <i>ELECTRICAL SETUP</i> .....                         | 6  |
| <i>INSTALL THE FLAME DIVERTER BRACKET</i> .....       | 7  |
| <i>INSTALL THE PILOT ASSEMBLY TO THE BURNER</i> ..... | 7  |
| <i>CONNECT TO GAS SUPPLY</i> .....                    | 8  |
| <i>CHECK THE WIRE CONNECTIONS</i> .....               | 9  |
| <i>CONNECT TO A WALL SWITCH</i> .....                 | 10 |
| <i>CONNECT TO A POWER SUPPLY</i> .....                | 10 |
| <i>SECURE THE VALVE BOX</i> .....                     | 10 |
| <i>DECORATIVE MEDIA REPLACEMENT</i> .....             | 10 |

## USE, CARE, & SERVICE

|  |    |
|--|----|
| LIGHTING INSTRUCTIONS .....                        | 11 |
| <i>FOR YOUR SAFETY, READ BEFORE LIGHTING</i> ..... | 11 |
| <i>LIGHTING</i> .....                              | 11 |
| <i>SHUTTING DOWN</i> .....                         | 11 |
| <i>PILOT APPEARANCE</i> .....                      | 11 |
| GAS TYPE CONVERSION .....                          | 12 |
| TROUBLESHOOTING .....                              | 13 |
| NOTES PAGE.....                                    | 14 |
| ELECTRONIC PILOT TROUBLESHOOTING .....             | 15 |
| WARRANTY .....                                     | 16 |

## IMPORTANT INFORMATION

### **CHECK TO BE SURE THAT THE PROPER FUEL GAS IS BEING USED WITH THIS PILOT KIT.**

The installation, including provisions for combustion and ventilation air, must conform with local codes, or in the absence of local codes, with the National Fuel Gas Code (ANSI Z223.1/NFPA 54).

This component and its individual shutoff valve must be disconnected from the gas-supply piping system when testing at pressures that exceed  $1/2$  psig. This is accomplished by closing the gas-supply line valve.

This component must be isolated from the gas-supply piping system by closing its individual manual shutoff valve during any testing of the gas-supply system at test pressures up to and including  $1/2$  psig.

A fireplace screen must be in place when the gas burner system is in operation. Unless other provisions for combustion air are provided, the screen shall have an opening(s) for introduction of combustion air.

### **WHEN GLASS FIREPLACE ENCLOSURES (DOORS) ARE USED, OPERATE THE BURNER SYSTEM WITH THE GLASS DOORS FULLY OPEN; BOTH SIDES IF THE FIREPLACE IS A SEE-THROUGH TYPE.**

This appliance may be installed in an aftermarket, permanently located, manufactured (mobile) home where not prohibited by local codes. Installation of appliances designed for manufactured homes or mobile homes must conform with *Manufactured Home Construction and Safety Standard, Title 24 CFR, Part 3280* in the U.S.; or with *CAN/CSA Z240 MH* in Canada; or with *ANSI/NCSBCS A225.1/NFPA 501A, Manufactured Home Installations Standard* when such as standard is not applicable.

Do not use this appliance if any part has been underwater. Immediately call a qualified service technician to inspect the appliance and to replace any part of the control system and any gas control that has been underwater.

## ELECTRICAL SAFETY INFORMATION

- To protect against electric shock, do not immerse cord or plugs in water or other liquid.
- Unplug from the outlet before servicing. Allow to cool before putting on or taking off parts.
- Do not operate with a damaged cord, plug, or after the appliance malfunctions or has been damaged in any manner. Contact the manufacturer for repair.
- Do not let the cord touch hot surfaces.
- When connecting, first make wire connections then plug appliance into the outlet.
- Do not use for purposes other than intended.
- **Use only a properly wired and inspected 120VAC (15 AMP minimum) Ground Fault Circuit Interrupter (GFCI) GROUNDED 3-wire receptacle with this unit.**
- Use only extension cords with a 3 prong grounding plug and rated for the power of the equipment.
- **The provisions of the National Electric Code as well as any local codes must be observed when installing the product.**

## SPECIFICATIONS

The **EPK-2M-AD** accommodates burners up to 30" (nat. gas only).  
 The **EPK-2M-AD/LP** accommodates burners up to 60" (L.P. gas only).

Refer to the burner owner's manual for minimum firebox dimensions.

| Model          | BTUs |      |
|----------------|------|------|
|                | Nat. | L.P. |
| EPK-2M-AD(/LP) | 120k | 180k |

**Table 1 - Maximum BTUs**

| Specification                 | Value   | Qty. |
|-------------------------------|---|------|
| Input electrical requirements | 120VAC / 15 AMP minimum / 60 Hz / GFCI outlet | N/A  |

**Table 2 - Technical Data**

# EPK-2M-AD REPLACEMENT PARTS LIST

**DO NOT REMOVE THE PILOT ASSEMBLY FROM THE VALVE OR IGNITER PACK.**

**Note: Photos not to scale**

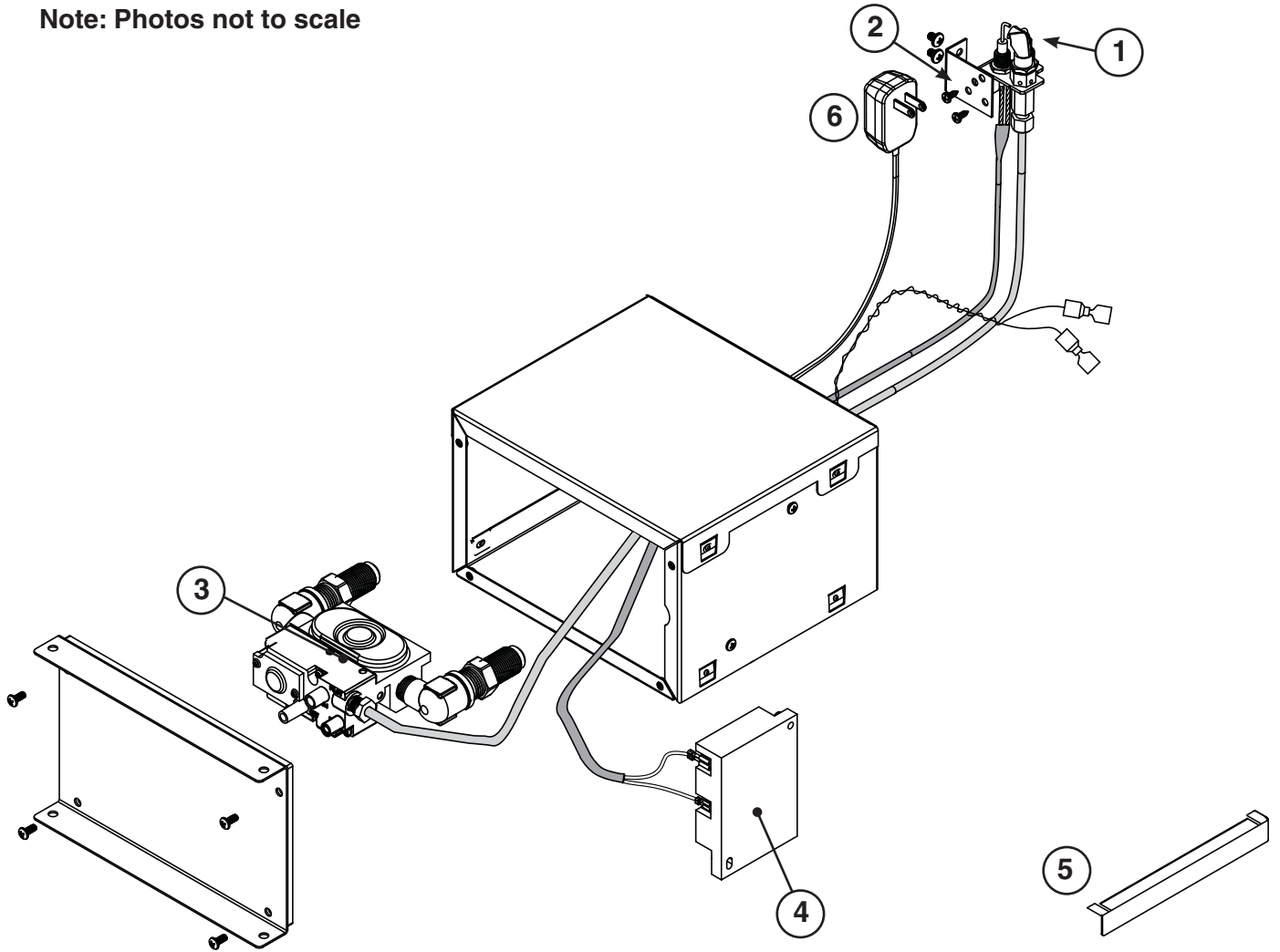

| Item | Description  | Part No.              | Qty.   |
|------|--|-----------------------|--------|
| 1.   | Pilot assembly (natural)<br>or<br>Pilot assembly (propane) | PAC-6-42<br>PAC-6-42P | 1<br>1 |
| 2.   | Pilot mounting bracket kit                                 | PB-51                 | 1      |
| 3.   | Control valve  | SV-52                 | 1      |
| 4.   | Control module   | IMP-1                 | 1      |
| 5.   | Flame diverter bracket                                     | SH-1                  | 1      |
| 6.   | Power supply   | TR-01                 | 1      |
| 7.   | Main valve wire harness *                                  | WH-08                 | 1      |

\* not shown

# INSTALLATION

**This safety pilot system must be installed by a qualified professional service technician. Instructions must be followed carefully when installing to ensure proper performance and full benefit from the burner system and safety pilot system.**

These instructions must be used as a supplement to the instructions supplied with the R.H. Peterson burner system. Follow the burner system instructions and make adjustments as appropriate for the addition of a safety pilot system. Use gas pipe sealing compound that is resistant to all gasses (or Teflon tape) and apply to all male pipe connections. **DO NOT** apply pipe sealing compound to any flare connections. Make sure that all connections are tight.

The valve system is shipped pre-assembled for easy installation onto the burner pan. **Perform installation with care ensuring not to damage the pilot assembly.**

## PREPARATION

If the burner that the valve system is to be added to is already installed, remove all decorative media, set aside to be reinstalled later, and disconnect the flex connector and adapter from the burner pan (using the instructions that came with the original burner).

**CAUTION:** Check to be sure this pilot kit is designed and labeled for the type of gas (natural or propane gas) supplied to the fireplace. See **GASTYPE CONVERSION** section if needed.

## ORIENTATION

Prior to installation, please review and determine the orientation of this unit by referencing Fig. 6-1. **Be sure the location of the valve housing is within reach of the burner (for flex connector and pilot assembly), the gas supply (for flex connector), the 120VAC receptacle (for transformer adaptor), and the wall switch (for ON/OFF control wires).**

**Note:** The flex connectors and wall switch are not included.

## CREATE VALVE HOUSING OPENING/FRAME

The valve housing must be secured in an opening/frame within the allowed range of the burner as mentioned in Fig. 6-1. The cutout for the valve housing is  $8\frac{5}{8}$ " wide by  $5\frac{1}{2}$ " high, with a mounting plate depth of  $8\frac{1}{2}$ " (see Fig. 6-2). Be sure to allow for wires/tubing clearance behind the housing. The valve housing will be secured upon completion of installation.

## ELECTRICAL SETUP

**A 120VAC (15 AMP minimum) GFCI GROUNDED 3-wire receptacle (not included) is required** within the vicinity of the fireplace to provide power to the unit. Power supply cord is located on the rear of the control box. Your individual installation may vary. **Observe the National Electric Code and all local codes.**

1. Wire the receptacle into the vicinity of the fireplace.
  - **Verify proper polarity of the receptacle.**
  - **If an extension cord is used, ensure it is a 3-wire GROUNDED cord that is rated for the power of the equipment. DO NOT use 2-prong adapters.**
  - **DO NOT TAMPER WITH THE EXTENSION CORD OR THE UNIT POWER-SUPPLY CORD.**

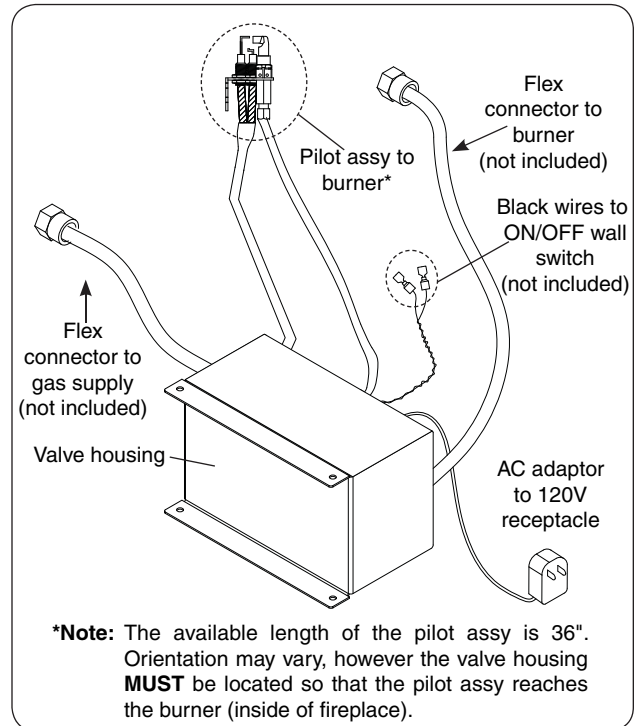

**Fig. 6-1** Overall orientation

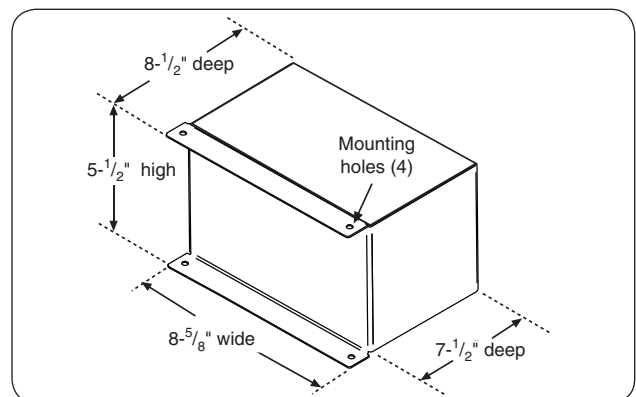

**Fig. 6-2** Valve housing cutout dimensions

## INSTALLATION (Cont.)

### INSTALL THE FLAME DIVERTER BRACKET

For installation on G4/G45 burners only. When properly installed onto the burner pan, the flame diverter bracket will promote quicker ignition.

**Note:** You must first install the flame diverter bracket before installing the pilot/igniter assembly .

1. Place the flame diverter bracket over the side edge of the burner pan, near the location the safety control system pilot bracket will be attached. It should be placed **approximately 2-1/4"** from the rear wall of the burner pan (see Fig. 7-1).
2. Tap the bracket lightly with a hammer to secure it in place.

### INSTALL THE PILOT ASSEMBLY TO THE BURNER

**CAUTION:** Use only the pilot assembly pre-assembled with this kit. Never substitute with an existing pilot.

**CAUTION:** Do not kink or damage the pilot supply tube, sparking, and sensor probes. Do not unscrew the gas line from the valve.

1. Route the pilot assembly coming from the valve system to the burner (inside of fireplace).
2. The pilot assembly comes with an L-shaped mounting bracket. Using the two black screws, fasten the bracket to burner pan (short side toward the back of the pan) using the pre-drilled holes in the pan (see Fig. 7-2).
3. Using the two (2) remaining screws, mount the pilot assembly and ground wire onto the bracket (See Fig. 7-3 and Fig. 7-4) and tighten until snug. **Check to be certain the pilot hood and probes are situated above the edge of the pan. Adjust if necessary.**

**WARNING:** Keep the pilot assembly clear at all times. Never cover any part of the pilot assembly.

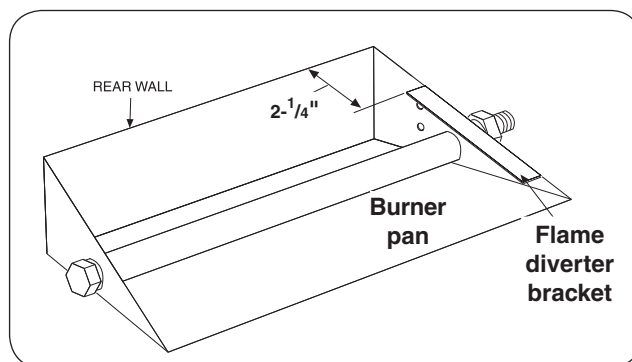

Fig. 7-1 Install diverter bracket (if applicable)



Fig. 7-2 Install pilot bracket

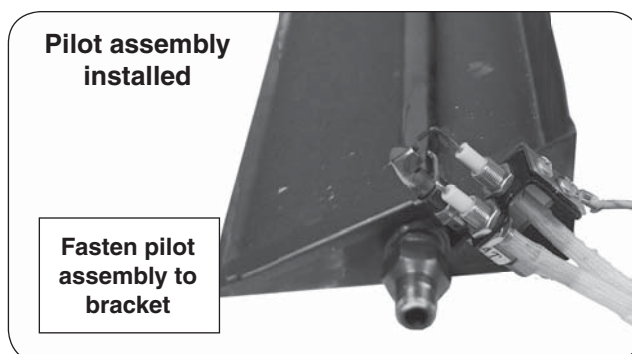

Fig. 7-3 Install pilot assembly

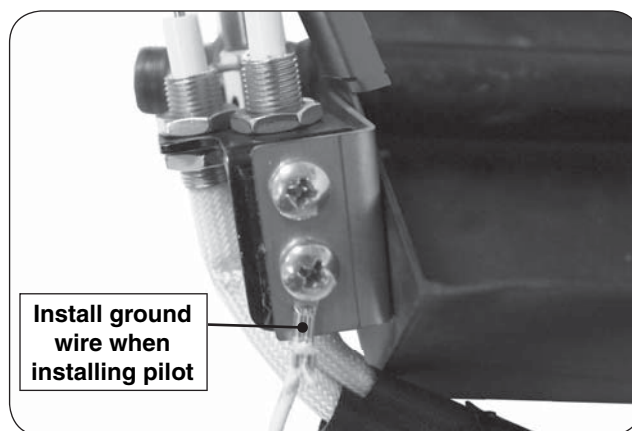

Fig. 7-4 Ground wire to bracket detail



## INSTALLATION (Cont.)

### CONNECT TO GAS SUPPLY

**Important:** Two flex connectors and adapters (not included) are needed to connect the unit to the gas supply and burner.

1. MAKE SURE THE FIREPLACE GAS SUPPLY IS TURNED OFF.
2. Locate the gas-supply stub inside the fireplace and remove the cap, if attached.

**CAUTION:** When removing the cap, make sure the stub does not turn, loosening the connection inside the wall.

3. Connect a  $\frac{1}{2}$ " flex connector (not included) to the **OUT** adapter found on the rear of the valve system. Tighten securely. See Fig. 8-1, A.

Next attach an adapter to the fuel injector / air mixer found on the side of the burner pan using a pipe compound resistant to all gasses. Tighten securely. Then attach the flex connector to the adapter. Tighten securely. See Fig. 8-1, B.

**Important: DO NOT remove the fuel injector / air mixer.**

4. **Be sure gas to the fireplace is off.** Connect another  $\frac{1}{2}$ " flex connector (not included) to the **IN** adapter found on the rear of the valve system. Tighten securely. See Fig. 8-2, C.

Next attach an adapter to the gas-supply stub using a pipe compound resistant to all gasses. Tighten securely. Then attach the flex connector to the adapter. Tighten securely. See Fig. 8-2, D.

5. **LEAK TEST:** Turn on the fireplace gas supply, and test at all connections for leaks using the appropriate soapy water solution. If bubbles appear, a leak is present. Turn off the gas and tighten at all connections. Repeat until no leaks are present. If a leak persists, turn off the gas supply and contact the local gas company or dealer. **NEVER USE A FLAME TO CHECK FOR LEAKS.**
6. Follow the instructions supplied with the Peterson burner system for any additional requirements regarding specific burner setup and placement.

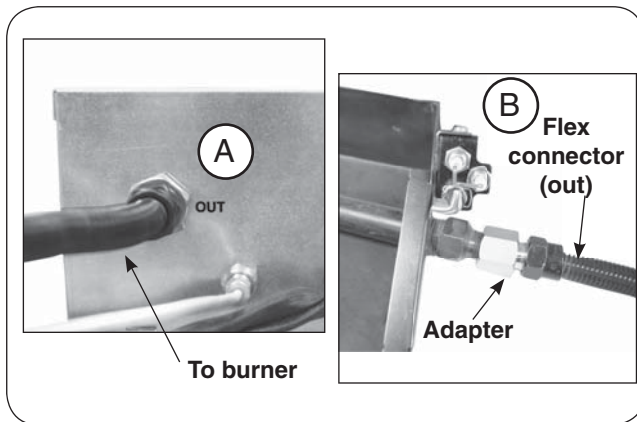

**Fig. 8-1** Connect to burner

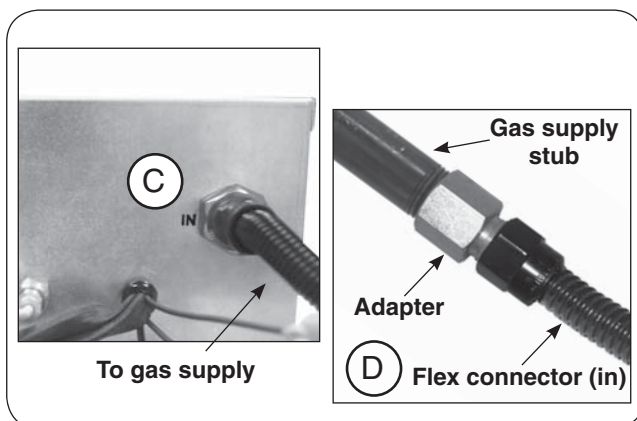

**Fig. 8-2** Connect to gas supply



# INSTALLATION (Cont.)

## CHECK THE WIRE CONNECTIONS

The unit comes completely assembled with the wiring harness already connected to the valve and control module. The AC Adaptor and wall switch wires comes connected to the control module. We recommend that you follow the steps below to ensure they have not become detached during shipping **before** connecting to a power supply.

1. Check that the wiring harness is fitted tightly into the connector on the green control module in the rear of the valve housing (Fig. 9-1).

**Note:** The two (2) spare black wires with coated male connectors coming from the wiring harness are used to connect to the wall switch. See Fig. 6-3 and the CONNECT THE TO A WALL SWITCH section.

2. Check that the female connectors on the AC adaptor wires are inserted fully into the male connectors on the control module (Fig. 9-1).
3. Check that the female connectors on the two black wires from the pilot assembly (wires marked "I" and "S") are inserted fully into the male connectors on the control module (Fig. 9-1).
4. Check the connections of the wires to the valve (see Fig. 9-2).

The diagram below (Fig. 9-3) shows the wiring layout for the complete unit.

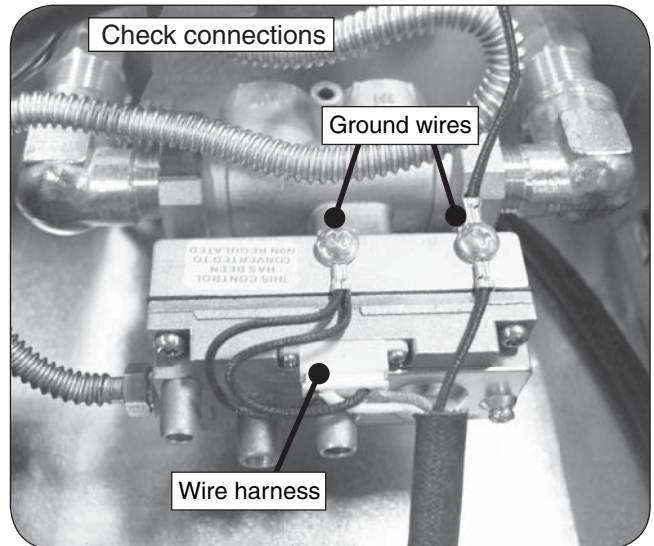
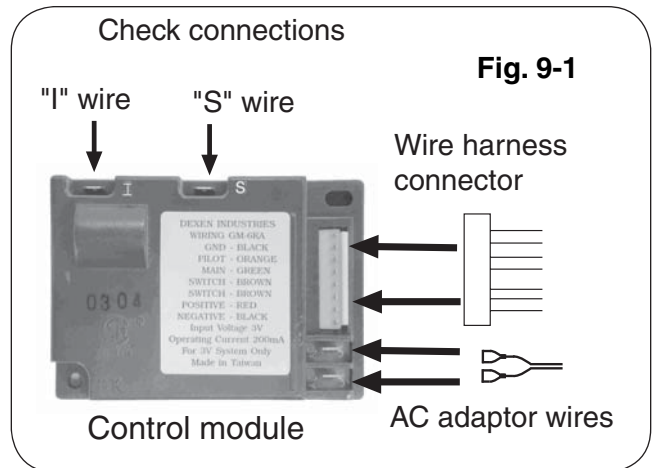

Consult this wiring diagram to ensure correct connection of wires.

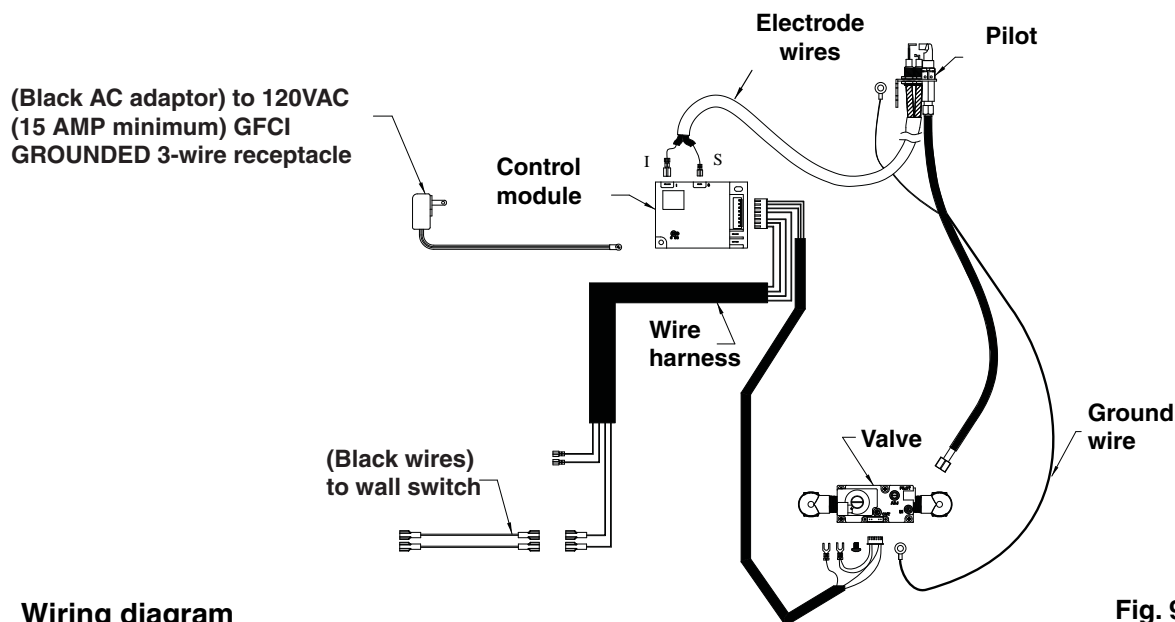

## CONNECT TO A WALL SWITCH

Connect the two black wires coming from the rear of the valve box to an ON/OFF wall switch (not included). Reference Fig. 10-1 for the black wires location.

## CONNECT TO A POWER SUPPLY

Locate the supplied power supply coming from the valve box. Then route it to the previously wired **120VAC (15 AMP minimum) GFCI GROUNDED 3-wire receptacle** and connect (see Fig. 10-2).

## SECURE THE VALVE BOX

Align the valve box into the opening/frame (previously made) and fasten using four screws (not provided).

**Important:** Be sure all wires/tubing are completely inside the opening and are not pinched or kinked when fastening the housing. See Fig. 10-3 & Fig. 10-4.

## DECORATIVE MEDIA REPLACEMENT

Refer to the burner instructions for proper replacement of decorative media.

**Important:** Keep lava granules/coals, sand/vermiculite, embers/glass, and all foreign objects away from the pilot assembly, and heat shield during media placement and at all times.

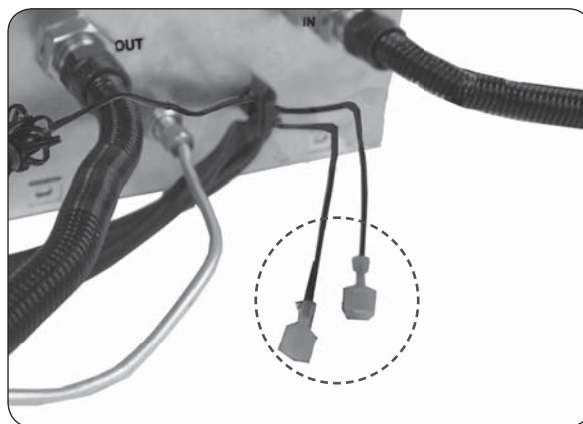

Fig. 10-1 Connect to wall switch

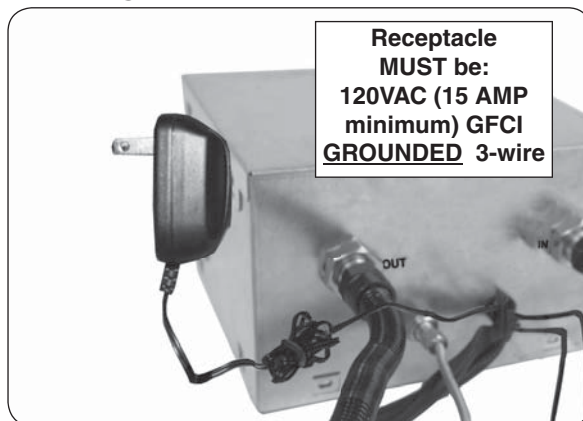

Fig. 10-2 Connect power supply

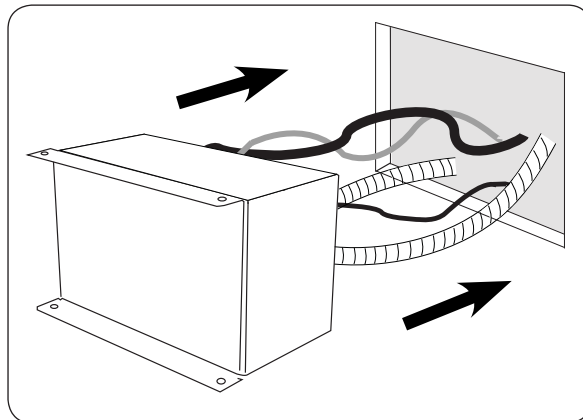

Fig. 10-3 Install valve box

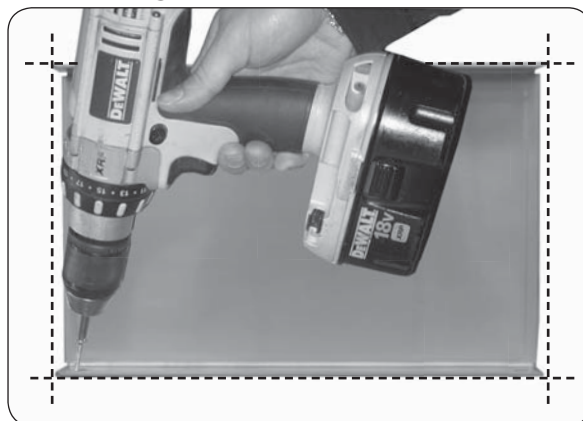

Fig. 10-4 Secure valve box

# LIGHTING INSTRUCTIONS

## FOR YOUR SAFETY, READ BEFORE LIGHTING

**WARNING:** If you do not follow these instructions exactly, a fire or explosion may result causing property damage, personal injury or loss of life.

- A. This appliance is equipped with an ignition device that automatically lights the pilot. DO NOT attempt to light the pilot by hand.
- B. **BEFORE OPERATING**, smell all around the appliance area for gas. Be sure to smell next to the floor because some gas is heavier than air and will settle on the floor.

### WHAT TO DO IF YOU SMELL GAS

- Do not light any appliance.
  - Do not touch any electric switch; do not use any phone in your building.
  - Immediately call your gas supplier from a neighbor's phone. Follow the gas supplier's instructions. If you cannot reach your gas supplier, call the fire department.
- C. Use only the control system to light the pilot. This valve will not operate if the pilot is not lit and stable.
  - D. Do not use this appliance if any part has been under water. Immediately call a qualified service technician to inspect the appliance and to replace any part of the control system and any gas control which has been under water. Attempted operation may result in fire or explosion resulting in property damage, personal injury or loss of life.

## LIGHTING

**CAUTION:** DO NOT attempt to light the pilot by hand.

1. Locate the ON/OFF wall switch. Flip the switch to the **ON** position. See Fig. 11-1.

The igniter will begin to spark. After the pilot lights and is established, the valve will automatically open and the burner will light.

**Note:** The ignition sequence will take approximately 5 seconds.

**WARNING:** If the pilot fails to light within 5 seconds, or the burner fails to light within 5 seconds of pilot lighting, flip the switch to the OFF position. Allow five (5) minutes for any gas in the unit to dissipate, then repeat step above. **IF YOU SMELL GAS, SEE STEP B AT BEGINNING OF LIGHTING INSTRUCTIONS.**

If the pilot fails to light after several tries, turn the system **OFF** and contact a qualified professional service technician.

## SHUTTING DOWN

Flip the ON/OFF wall switch to the **OFF** position.

## PILOT APPEARANCE

Periodically check the pilot for proper flame pattern. The pilot flame should encircle the generator tip, and is preset at the factory (see Fig. 11-2).

**If the pilot flame burns incorrectly; shut down completely and contact a qualified professional service technician.**

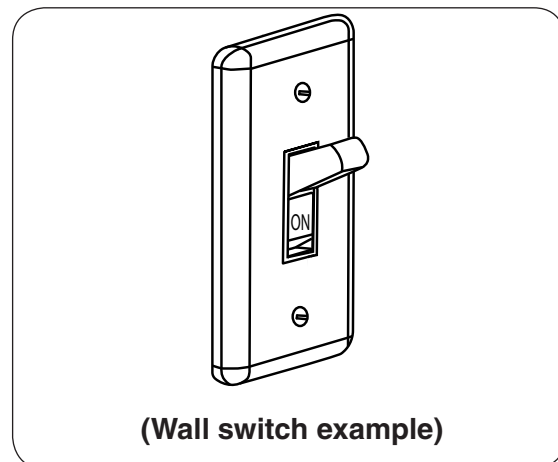

Fig. 11-1 Lighting

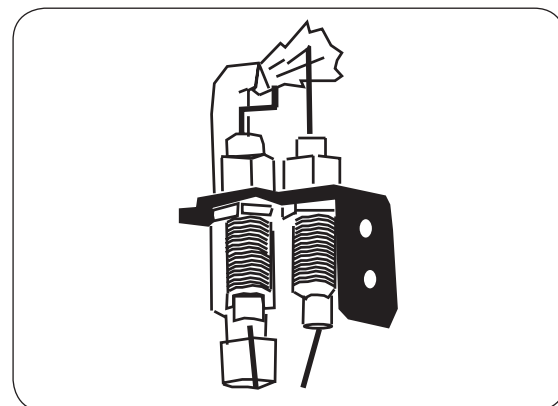

Fig. 11-2 Proper pilot flame

## GAS TYPE CONVERSION

To convert this appliance from natural to propane gas or propane to natural gas, carefully follow the steps below:

1. **Ensure the unit is OFF and completely cool, the gas supply to the unit is turned off, and the power supply is disconnected.**
2. Remove the pilot hood from the pilot assembly as shown in Fig. 12-1.  
**Note:** The pilot hood is secured in place with a retainer pin. Slightly flex open (or completely remove) the pin so that the pilot hood can be easily removed.
3. Using a flat head screwdriver, unscrew the orifice from the pilot assembly (see Fig. 12-2). Locate the replacement orifice and fasten it into the pilot assembly.
4. Replace the pilot hood onto the pilot assembly. Ensure the retainer clip is secured in place.

**CAUTION:** During any conversions, all components must be set/converted for the appropriate gas type (i.e. burner orifice, regulator, etc.). Contact your dealer and a qualified professional service technician.

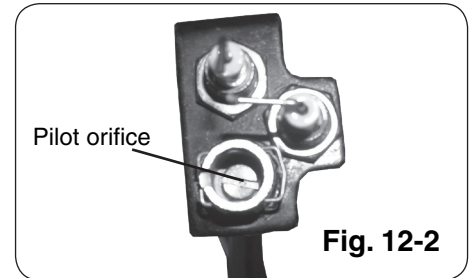
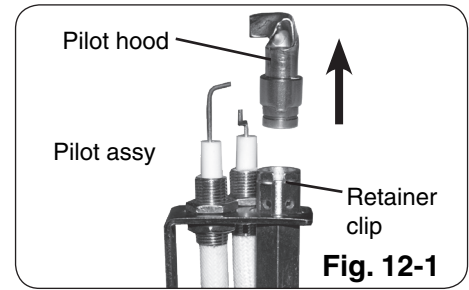

## TROUBLESHOOTING

| PROBLEM   | CAUSE   | SOLUTION  |
|---|---|---|
| 1. Pilot will not light   | <ul style="list-style-type: none"> <li>a. Obstruction in pilot gas supply or pilot gas-supply line is kinked</li> <li>b. Inadequate gas supply</li> <li>c. Air in line</li> </ul>                   | <ul style="list-style-type: none"> <li>a. Clear out obstruction. Replace pilot gas-supply line if kinked</li> <li>b. Have gas pressure checked by installer or gas supplier</li> <li>c. Air should clear; attempt to relight</li> </ul>   |
| 2. No spark at pilot  | <ul style="list-style-type: none"> <li>a. Loose wires</li> <li>b. AC adaptor</li> <li>c. Faulty wall switch</li> </ul>  | <ul style="list-style-type: none"> <li>a. Check all wires are securely in place</li> <li>b. Ensure AC adaptor is connected to a 120VAC (15 AMP minimum) GFCI grounded 3-wire receptacle</li> <li>c. Replace the wall switch</li> </ul>  |
| 3. Pilot lights, but main burner will not   | <ul style="list-style-type: none"> <li>a. Wire leads are not connected to proper valve terminals or toggle switch terminals not tight</li> <li>b. AC adaptor</li> <li>c. Defective valve</li> </ul> | <ul style="list-style-type: none"> <li>a. Make sure all wire leads are tight and attached to proper terminals see wiring diagram in INSTALLATION section</li> <li>b. Ensure AC adaptor is connected to a 120VAC (15 AMP minimum) GFCI grounded 3-wire receptacle</li> <li>c. Replace valve</li> </ul> |
| 4. Burner system not burning properly   | <ul style="list-style-type: none"> <li>a. Low flame/uneven flame</li> </ul>   | <ul style="list-style-type: none"> <li>a. Check for low gas pressure; should have operating pressures of 7" w.c. for natural gas, 11" w.c. for propane at manifold</li> <li>b. Burner should be filled completely with sand or vermiculite</li> </ul>   |
| 5. Burner system shuts down during operation  | <ul style="list-style-type: none"> <li>a. Glass doors closed, causing excessive heat buildup</li> <li>b. Pilot electrode not properly set to pilot location</li> </ul>                              | <ul style="list-style-type: none"> <li>a. Open glass doors</li> <li>b. See INSTALL THE PILOT ASSEMBLY TO THE BURNER section</li> </ul>  |
| 6. Intermittent ignitor spark during use (main burner has been burning for well over a minute). | <ul style="list-style-type: none"> <li>a. Decorative media covering pilot assembly</li> </ul>   | <ul style="list-style-type: none"> <li>a. Clear all decorative media and foreign material from around the pilot assembly</li> </ul>   |

Periodically inspect the pilot assembly and maintain it free of obstruction or debris. If the pilot flame is not blue with possibly yellow tips and does not impinge on the electrodes or if the pilot does not stay lit, contact a qualified professional service technician to service the pilot system.

Please use this page to record any information that you may want to have at hand.



## Detail A

### Electrode (A)

When adjusting the spark electrode (if necessary); NEVER adjust the electrode by bending the wire. ALWAYS adjust the electrode by loosening the retainer nut(s), then adjust accordingly.

The minimum gap between the spark electrode/heat sensor and the pilot flame hood is  $\frac{1}{8}$ ". The maximum is  $\frac{5}{32}$ ".

If the electrode ceramic is loose in the threaded barrel; the pilot assembly must be replaced.

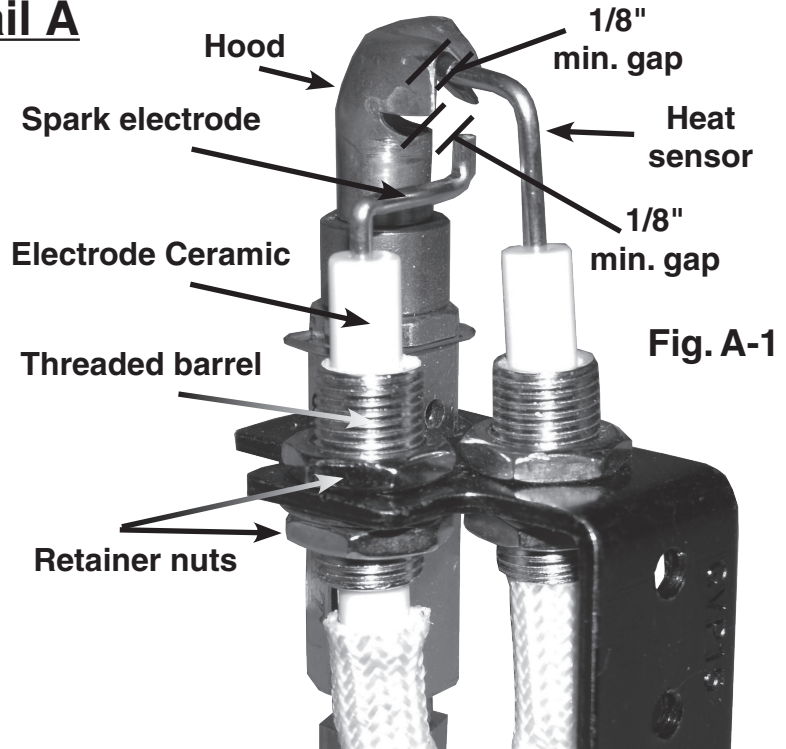

Fig. A-1

## Detail B

### Terminal Connections (B)

All of the connections on the control module must be properly attached. If the spade terminals are loose; inspect to ensure they correctly appear as detailed below. Use needle nose pliers to clamp down on the center/sides of the terminals if needed (to provide a tight fit.) See Fig B-3 below.

#### Spade Terminal Detail



Ensure that spade terminals (S and I) are attached securely

Ensure that multi-wire connector is properly engaged

Control Module (DESIGN MAY VARY) (Fig. B-2)

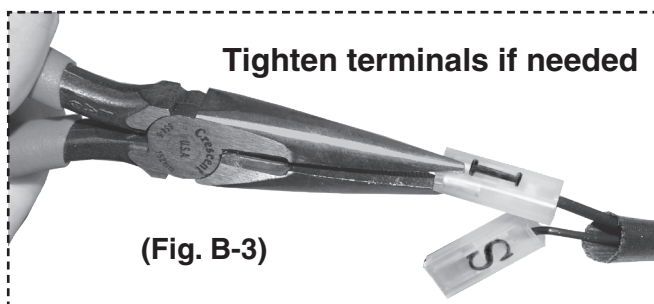
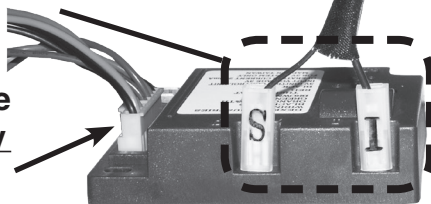

## Detail C

(Fig. C-1)

DO NOT bundle tightly together as shown

### Assembly Wires (C)

DO NOT bundle the excess pilot assembly wires tightly together as this can reduce the intensity of the spark.

# WARRANTY

## PETERSON INDOOR VENTED DECORATIVE GAS APPLIANCE LIMITED WARRANTY

Robert H. Peterson Co. ("RHP") warrants your Real Fyre® vented decorative gas appliance to be free from defects in material and workmanship. This warranty is for indoor use only.

Peterson vented ceramic refractory gas logs are warranted for **as long as you own them (lifetime)**.

Peterson vented burner assemblies excluding valves, pilots, and controls are **WARRANTED for TEN (10) YEARS**.

Peterson glass, gems, nuggets, and fiber-ceramic blend gas logs are warranted for **FIVE (5) YEARS**.

SPK-26 controls are warranted for **THREE (3) YEARS**.

APK-17 controls (including -17 valve) are warranted for **TWO (2) YEARS**.

All other Peterson valves, pilots, and controls are warranted for **ONE (1) YEAR (excluding batteries)**.

### A COPY OF YOUR SALES SLIP FOR PROOF OF PURCHASE IS REQUIRED

This warranty applies to the original purchaser for products which are installed in the United States or Canada and which are operated and maintained as intended for single family residential usage (If the grill is installed in a multi-user setting, a separate Multi-User Limited Warranty applies and is available from R.H. Peterson Co.). This warranty is valid only with proof of purchase, shall commence on the date of purchase, and shall terminate (both as to original and any replacement products) on the anniversary date of the original purchase of the product stated on the above schedules.

This warranty covers defects in material and workmanship. This warranty **does not** cover parts which become defective as a result of negligence, misuse, use not in compliance with the Owner's Manual/Installation Instructions, accidental damage, improper handling, improper storage, improper installation, **lack of required routine maintenance** (as specified in the Owner's Manual/Installation Instructions), electrical damage, local gas impurities or failure to protect against combustibles. Product must be installed (and gas must be connected) as specified in the Owner's Manual/Installation Instructions by a **qualified professional installer**. Modifications to products which are not specifically authorized will void this warranty. Accessories, parts, valves, remotes, etc. when used must be Peterson products or this warranty is void. Warrantied items will be repaired or replaced at Peterson's sole discretion. This warranty **does not** apply to rust, corrosion, oxidation, or discoloration unless the affected part becomes inoperable.

This warranty **does not** cover labor or labor related charges, except as provided by separate specific written programs from the Peterson Co. All repair work must be performed by a qualified professional service person and requires prior approval of Peterson.

Peterson may require the defective product or part to be returned to the factory to determine the cause of failure. Peterson will pay freight charges if the product or part is determined to be defective. This warranty does not cover breakage in shipment from our (Independent) distributor to its customer if the damage is determined to have occurred during that shipment.

This warranty specifically excludes liability for **indirect, incidental, or consequential** damages. Some states and provinces do not allow the exclusion or limitation of incidental or consequential damages, so the above exclusion may not apply to you. This warranty gives you specified legal rights, and you may have other rights that vary from state to state or province.

For additional information regarding this warranty, or to place a warranty claim, contact the R. H. Peterson dealer where the product was purchased.

When contacting your Peterson dealer or the R. H. Peterson Co., please provide the following information:

- Your name, address, telephone number, e-mail
- Sales receipt showing where purchased and date purchased
- Model number, serial number of product, date code
- Relevant information: installer, additions, repairs, when defect was first noted

**TO REGISTER YOUR PRODUCT ONLINE GO TO: [WWW.RHPETERSON.COM](http://WWW.RHPETERSON.COM),  
AND CLICK ON PRODUCT REGISTRATION. THANK YOU FOR YOUR PURCHASE.**

|                         |                         |                    |                    |
|-------------------------|-------------------------|--------------------|--------------------|
| <b>Quality Check</b>    |                         | <b>Date:</b> _____ |                    |
| <b>Leak Test:</b> _____ | <b>Burn Test:</b> _____ | <b>Gas Type:</b>   | <b>Nat. / L.P.</b> |
| <b>Inspector:</b> _____ |                         |                    |                    |