

Primary Usage

Reference No.

Sign. and date

Copy inv. No.

Repl. Inv. No.

Sign. and date

Orig. Inv. No.

4" Galvanized Steel Revision Slot Drain

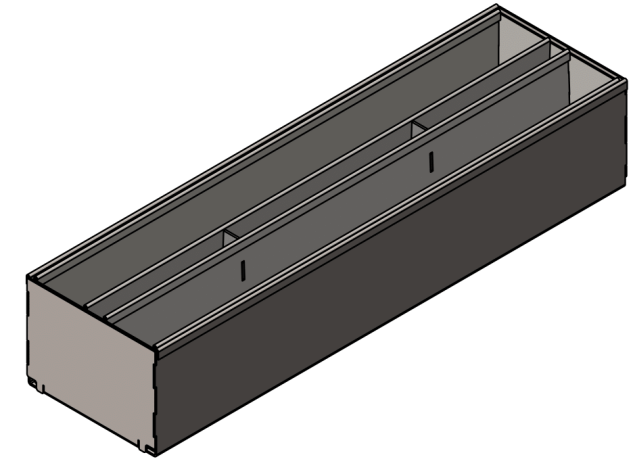
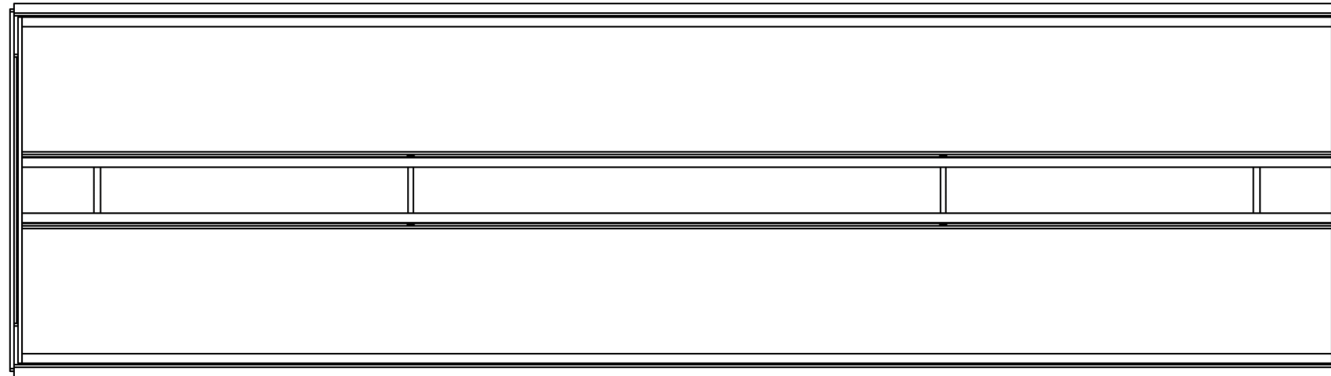
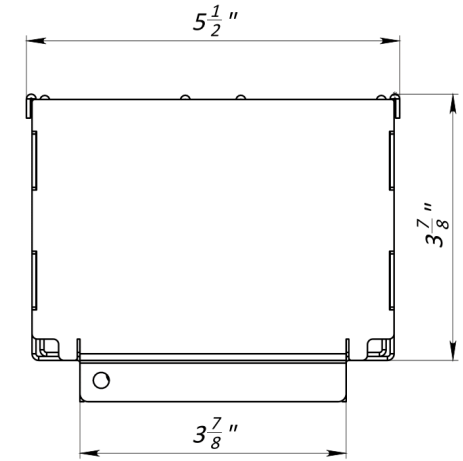
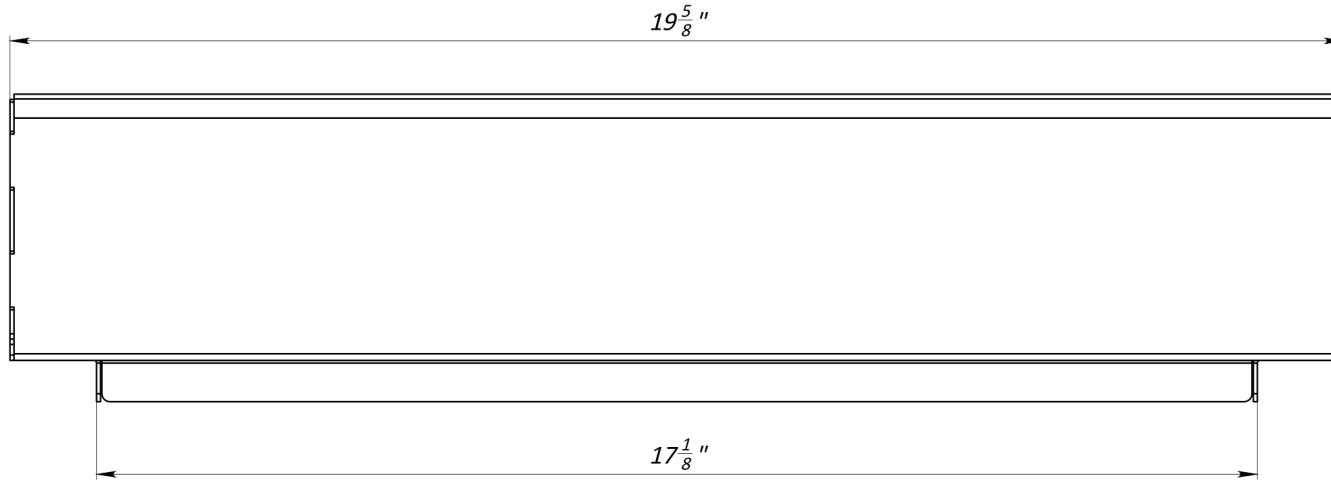

- 1. Area of water intake slots 13 sq in
- 2. Deviation of the actual weight of the nominal can be up to 10%

										Art. 20175-1T-100
										4" Galvanized Steel Revision Slot Drain
										Let. Weight (lb) Scale
										20175-1T-100
										5.43 1:2
										Sheet Sheets 1
										Galvanized Steel
										VODALAND