

LLC «FIBERIKA»

Ukraine, Cherkasy region, Cherkasy

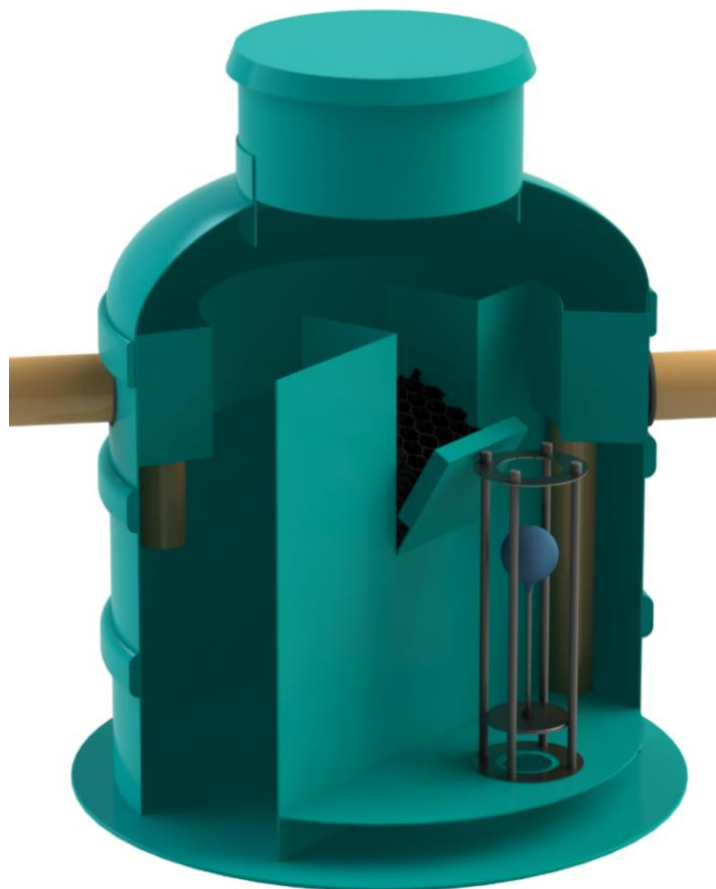

TECHNICAL PASSPORT

**SEPARATOR OF OIL PRODUCTS AND SAND VODALAND
OilBase100
(OB1)**





EN 858
Class I

OIL SEPARATOR
OB1
with sludge trap

NS ____

Volume of the separator ____ (l)
Volume of the sludge trap ____ (l)
Storage capacity for light liquids ____ (l)
Depth of maximum grease storage quantity ____ (mm)

Material: Glass fibre reinforced plastics

Certification body: ICECON S.A

LLC «FIBERICA» Ukraine, Cherkassy

CONTENTS

<u>1. GENERAL INFORMATION.....</u>	<u>4</u>
<u>2. OPERATING PRINCIPLE AND TECHNICAL CHARACTERISTICS</u> <u>.....</u>	<u>5</u>
<u>3. RECOMMENDATIONS FOR OPERATION AND MAINTENANCE..</u>	<u>7</u>
<u>4. TRANSPORTATION AND STORAGE.....</u>	<u>9</u>
<u>5. RECOMMENDATIONS FOR INSTALLATION.....</u>	<u>11</u>
<u>6. SAFETY GUIDELINES.....</u>	<u>20</u>
<u>7. WARRANTY OBLIGATIONS.....</u>	<u>22</u>
<u>8. TRANSFER ACCEPTANCE CERTIFICATE.....</u>	<u>28</u>



1. GENERAL INFORMATION

This data sheet has been developed and issued for the Vodaland **OilBase100*** oil and sand separator with sludge chamber (hereinafter referred to as "**OB1**"), which is a vertical cylinder made of reinforced fiberglass.

Fiberglass is a composite material consisting of glass filler and polymer binder. The main properties of fiberglass are high corrosion resistance, low specific weight, high strength, low thermal conductivity, dielectric properties.

Separator of oil products **OB1** is manufactured with capacity from 3 l/s to 45 l/s (by individual order, it is possible to manufacture products of other capacity).

Separator **OB1** is an autonomous modular filtration system designed to capture and retain oil products and suspended solids from rain, melt and industrial wastewater.

This filtration system can be used at an individual facility or a group of facilities: parking lots, gas stations, car services, garage complexes, industrial enterprises, logistics centers, etc.

Separator OB1 provides wastewater purification to the content of: oil products - no more than 5.0 mg/l (**Class-I, according to EN 858-1/2:1002**).

The facility is designed to receive liquids with temperature up to 60°C.

The manufacturer reserves the right to make changes to the design aimed at improving the performance of the product.

Long and proper operation of the unit depends on its correct use and maintenance.



ANY OPERATIONS WITH THE PRODUCT ARE CARRIED OUT ONLY AFTER FULL STUDY OF THE TECHNICAL PASSPORT

**The following designations may appear in the text of this Technical Passport: Structure, Product, Installation. The previous name OLE Rainpark/ Vodaland may be used.*

***The manufacturer does not guarantee the degree of purification in case of: failure to comply with the operating rules; exceeding the permissible performance loads, concentrations of contaminants at the inlet to the OilBase100 oil separator!*

2. OPERATING PRINCIPLE AND TECHNICAL CHARACTERISTICS

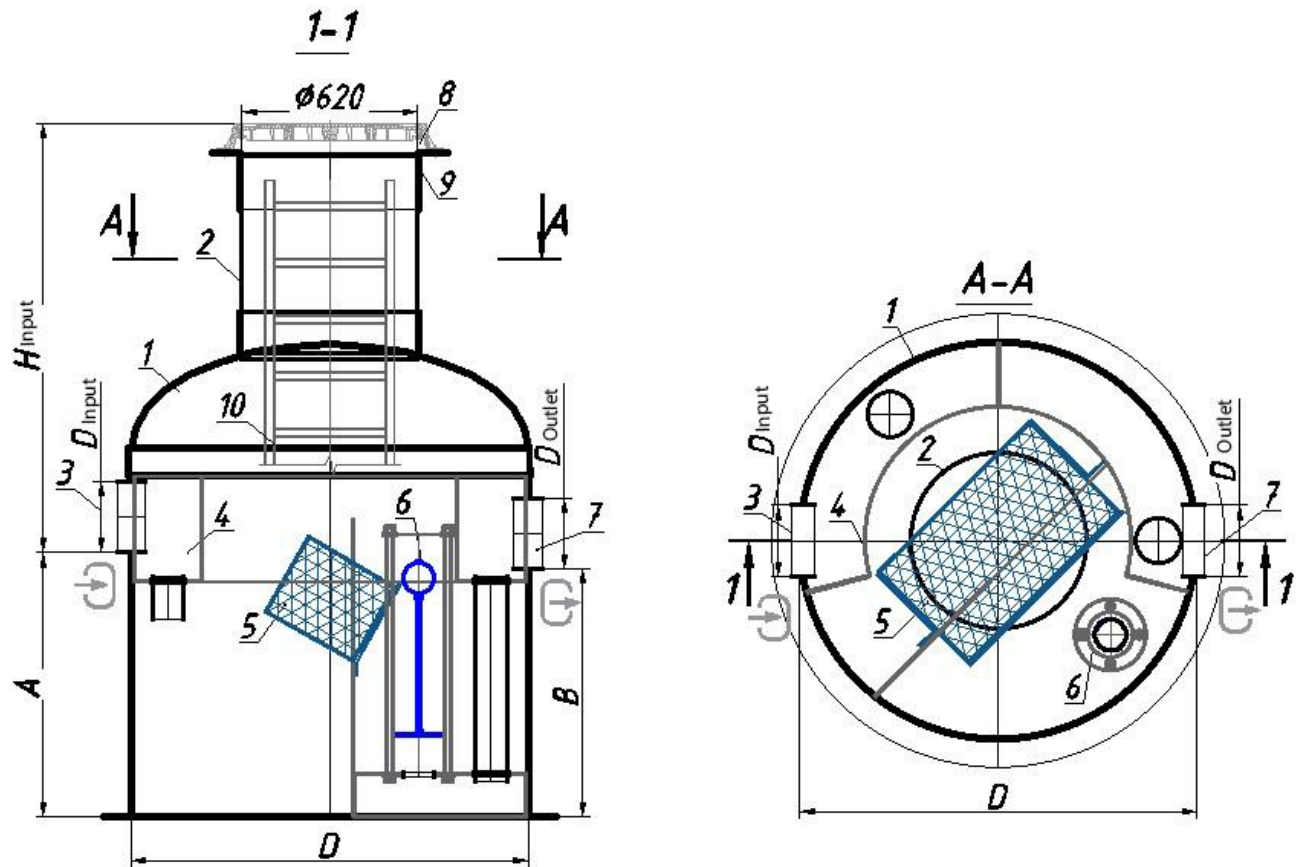
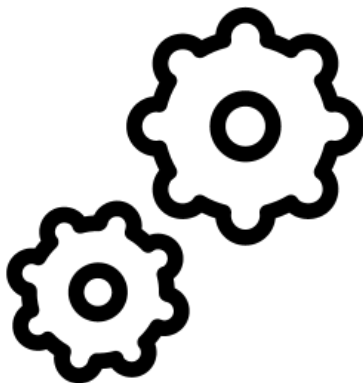

Fig.1* Separator of oil products Vodaland OilBase100(OB1)** with sludge chamber.

Technological scheme

- 1 - body*** of the OB1 oil and sand separator; 2 - maintenance neck;
 3 - inlet pipe (general); 4 - bypass; 5 - water supply pipe to the separator; 6 - coalescence unit; 7 - locking device;
 8 - water outlet pipe from the separator; 9 - outlet pipe (general);
 10 - hatch (or fiberglass cover); 11 - floating neck flange.
 H - depth of the supply pipeline, m (determined by the design organization).



Vertical body (1) Oil separator OB1, divided into two chambers by a special block (6).

The plant operates in self-powered mode. Waste water through the inlet pipe (3) enters the distribution chamber of the bypass (4). At low intensity of rainfall, wastewater is supplied for purification, and with increasing intensity - precipitation is discharged through the bypass tray (4) past the purification system. In the first compartment / chamber OB1 there is a gravitational detention of suspended solids, sand, etc., as well as part of oil products. Suspended solids in the form of sludge settle to the bottom of the structure. Then the wastewater flows by gravity through the coalescence unit (6) into the second chamber. Passing through the coalescing blocks (6), the main retention of oil products and oils occurs. Further, the drains through the outlet pipe (8,9) enter the sewage network.



To control the level of oil products inside, a shut-off device (7) is installed, which closes, blocking the flow, at the maximum volume of oil products; pressure losses increase and water in this case can only pass through the bypass (4), bypassing the purification. It is necessary to pump out the contamination and pull the float of the shut-off device upwards (6) by the cord/line for further proper operation of the oil separator (for more information see "Operating and maintenance recommendations").

**Detailed dimensions, technical data and equipment are given in the section "Transfer Acceptance Certificate".*

*** The manufacturer reserves the right to make changes to the design, which are aimed at improving the operation of the product!*

****Permissible deviation in the manufacture of products is up to 1-3%.*

***** When putting the structure into operation, it is necessary to OPEN the locking device - pull the rope/string up the float of the locking device, which automatically blocked the outlet when it was first filled with water during installation of the product.*

3. RECOMMENDATIONS FOR OPERATION AND MAINTENANCE



The unit operates in self-powered mode and does not require daily maintenance.

Maintenance* of OB1 consists in:

- From time to time to control the correctness of its operation visually (fastening of ladders; deformation or displacement of partitions of coalescing blocks, damage to pipes / sensors; water level, subsidence / collapse of the soil around the tank, etc. ***(at least once a month)***).
- Removal of oil products and retained sand. Pumping is performed with the help of a sewage machine as contaminants accumulate** ***(at least once every 6 months, mainly in spring and autumn)***).
- Full unloading of the product - B ***(at least once every 24 months)***).

A - Partial maintenance/unloading of OB1 is necessary (see Fig. 1):

- 1) Remove the hatch (or fiberglass cover) from the OB1 oil separator and leave the structure open for 10-15 minutes for ventilation or check the gas content with a gas analyzer***.
- 2) Lower the hose into the structure (chamber with a shut-off device / float) (approx. 100-400 mm from the junction of the neck with the body) and pump out the oil products collected on the surface of the liquid (up to 15-25% of the total volume of water).
- 3) Lower the hose to the bottom of the structure in the first chamber from the entrance to remove sand (sediment), pump out the sediment - the entire contents of the first chamber (up to 50% of the total volume of the structure).
- 4) Fill the oil separator ***OB1*** with clean water (technical) to the level of the bottom of the outlet pipe (until water appears in the well after the separator). ***Important: when filled with water, the Float sinks and blocks the flow inside the separator.***
- 5) Set the Float to "operation" mode - the top of the float should be floating on the surface of the liquid. To do this, pull the rope / line, which is attached at one end to the neck and the other to the Float, until the Float pops up, opening the outlet.

**** Maintenance should be carried out without wastewater inflow (in the absence of rain and melt runoff or discharge of irrigation and washing wastewater).***

***** To control the level of sediment and oil products, it is recommended to install a sand and oil product sensor and an alarm device.***

******It is allowed to go down into the oil separator only after its prolonged ventilation with open lids (at least 1 hour) in compliance with the rules of sewer well maintenance.***

B - When the OB1 is completely emptied, carry out points 1 to 3 and the following (see Fig. 1):

- 1) Pump all liquid contents out of the structure (to allow descent for inspection and maintenance)*.
- 2) Flush the internal walls and equipment with water at a pressure sufficient to flush contaminants from the internal walls and surface of the units (but not more than 100 bar). If necessary, take out the float of the locking device.
- 3) Pump out the flushing water with a sewage machine.
- 4) Go down into the building to check the condition of the casing, internal surface and internal structures visually for damage (fastening of ladders; deformation or displacement of overflow trays, partitions and plates of coalescing units; damage to pipes/sensors and an).

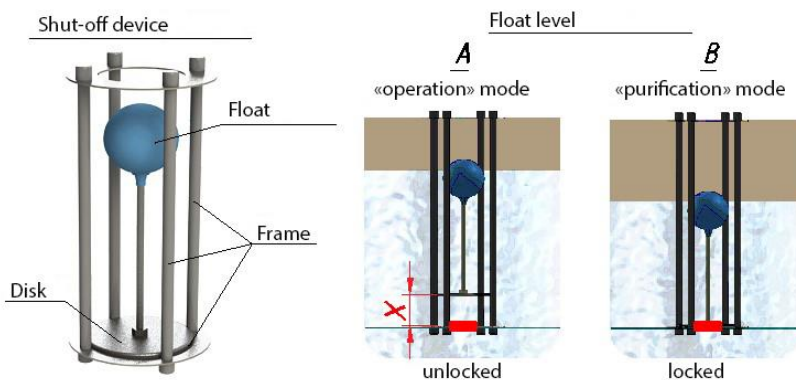

5) Install the Float in place in the frame (lower it from the top or push it between the pipes).

6) Fill the oil separator OB1 with clean water (technical water) to the level of the bottom of the outlet pipe (until water appears in the well after the separator). **Important: when filled with water, the Float sinks to the bottom and blocks the flow.**

7) Set the Float to "operation" mode - the top of the float should float on the surface of the liquid. To do this, pull the rope / line, which is attached at one end to the neck and the other to the Float, until the Float pops up, opening the outlet.

8) In the case of sensors. Remove the sensors from the structure before lowering the hose. Rinse the sensors with water or a mild detergent (e.g. dishwashing detergent). After filling the installation, replace the sensors in place. Dispose of the flushing water as sludge.

*** It is forbidden to leave the structure empty for more than 30 minutes! (subject to the installation conditions according to the recommendations of this technical passport section "Installation recommendations", it is permissible to leave the structure empty for a short time, at a low groundwater level (0.5 m below the bottom of the foundation slab), up to 1 hour. Otherwise, there is a possibility of floating products).**

4. TRANSPORTATION AND STORAGE

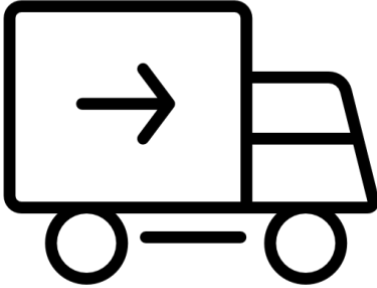

It is recommended **to transport** fiberglass products by vehicles in compliance with the Rules for the carriage of goods by motor transport of Ukraine. Shipping/unloading operations should be carried out without hitting the body. Construction slings are used for shipment and installation of the structure.

The structure is installed on wooden stands and secured to prevent displacement, falling and mechanical damage.

The permissible speed during transportation is 80 km/h.

Fiberglass products should be protected from collision, falling, bumps and mechanical damage.

During transportation, the products must be laid on a flat surface of vehicles, protecting from sharp metal corners and edges of the platform.

All open holes (pipes, necks, etc.) must be protected with film or plugs during shipment to prevent the infiltration of foreign objects, rubbish, dust and precipitations. Various soft materials are used as protective materials: rubber harnesses and rings, fabric, film made of polyvinyl chloride, polyethylene or polypropylene, etc. The occurrence of foreign objects, rubbish, dust and precipitation inside the enclosure does not adversely affect the operation of the system, while maintaining the integrity of internal elements and their fasteners. It is enough to remove these objects, and water from the casing.

It is not allowed to dump fiberglass products from vehicles.

It is forbidden to use steel cables or chains to lift or move the body of fiberglass products. It is prohibited to drag the container on the ground to the place of storage and installation.

****During transportation by other means of transport, it is recommended to follow all other rules of cargo transportation depending on the type of transport.***

*****The Customer is responsible for the quality of loading and unloading operations and storage conditions at the construction site.***

Storage



Before unloading, it is necessary to perform a visual inspection in order to detect possible damage received during transportation: severe cracks, splits, scratches, delamination or other mechanical damage. In case of detection of defects, it is necessary to inform the Supplier of the product about the damage, take photos, draw up an act of detected defects.

The place of storage of fiberglass products should be fenced to prevent mechanical damage by construction equipment.

Storage is allowed in: open air, but with closed neck openings that prevent atmospheric precipitation from entering the product; indoors or other conditions subject to the requirements that exclude mechanical damage and location closer than 1 m from heating and heating appliances.

If the products are laid out along the pit, before the excavation of the pit, they must be placed in such a way that they are not damaged during the maneuver of the equipment and the personnel operating the equipment can see the located products.

In cases of long-term storage (more than 1 year), fiberglass products should be placed on a flat surface under a shed or covered with tarpaulin or other dense material.

Fiberglass products that are in long-term storage for more than 1 year, before use and installation should be re-checked for possible mechanical damage received during storage.

5. RECOMMENDATIONS FOR INSTALLATION

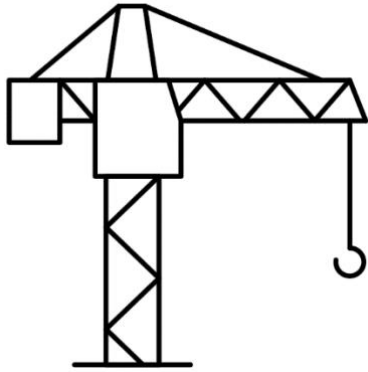

During the installation of the product* it is necessary to be guided by the regulations and requirements established in: State Building Code A.3.2-2-1009 "Occupational health and safety in construction"; State Building Code C. 2.1-10-1009 "Foundations and bases of structures".

Installation of the structure is a dangerous stage in terms of safety and labor protection. Before installing the equipment, it is necessary to check the implementation of the following measures to ensure safety and labor protection: Correct organization of the foundation pit shape, which excludes the possibility of soil collapse; Organization of the foundation pit fence; Organization of the fence of driveways; Correct selection of lifting equipment and correctness of lifting operations.



The installation of the tank in the ground should be carried out by a specialized organization, in accordance with the technical passport, working design and design of the work.

Installation of fiberglass products is carried out using geodetic instruments with a particularly careful check of compliance with the design marks and alignment along the axes.

All performers (engineering and technical personnel and workers) who install the products must be previously introduced to the specifics of working with fiberglass products.

Personnel must be provided with personal protective equipment, overalls and footwear, serviceable tools.

It is necessary to conduct a visual inspection of the installation and check the completeness of the product in accordance with the equipment (see "Transfer Acceptance Certificate" of this technical passport).

Clean the surface of the pit/reinforced concrete base and the unit casing from foreign objects and construction rubbish. Check the horizontal surface of the pit / reinforced concrete base.

****Before installation, check the absence of additional loose equipment inside the body, which was placed inside during transportation and storage.***

Table 5.1 Degree of compaction of backfill during installation

*Sealing method	Minimum weight, kg	Number of passages to achieve the required compaction category according to the Proctor method		Maximum thickness of the compacted layer, mm	Minimum sprinkling layer from the body to the seal, mm
		95%	88%		
Manual stamp	15	3	1	150	100
Vibrating stamp	70	3	1	100	150
Vibrating plate	50	3-5	1-2	100	150
	100	3-5	1-2	150	150
	100	3-5	1-2	100	100
	400	3-5	1-2	300	300
	600	3-5	1-2	400	500

Table 5.2 Recommended backfill materials

Backfill material	Fractional diameter, mm
Sand	< 3
Granite sieving	0 - 5
Rubble	0 - 10
Mixture of sand and granite sieving	0 - 5
Carving	-

Installation of equipment*:

- 1) Installation of equipment is carried out on a previously prepared base.
- 2) Preparation of the bottom of the pit:
 - **absence of groundwater:** the pit is developed 100 mm below the bottom mark of the product. At the bottom of the pit, a 100 mm high cushioning/levelling layer of sand is added and compacted (see Fig. 2).
 - **presence of flood or groundwater:** the procedure for excavation is similar to that for soils with low/absent groundwater table, but with parallel groundwater pumping/dewatering. The products are installed on a prepared reinforced concrete slab (after concrete has reached the design strength), designed for loading the product (calculation, manufacture and installation rules of reinforced concrete slabs are specified in the relevant section of the project) (see Fig. 3).
 - **it is not allowed to prepare the bottom of the pit in the presence of snow, ice in the pit;** also, it is not allowed to use frozen soil as a levelling layer.

(It is recommended for reinforced concrete slabs to use reinforcement class not lower than A-III and concrete class not less than B-25, slab thickness not less than 100 mm.)

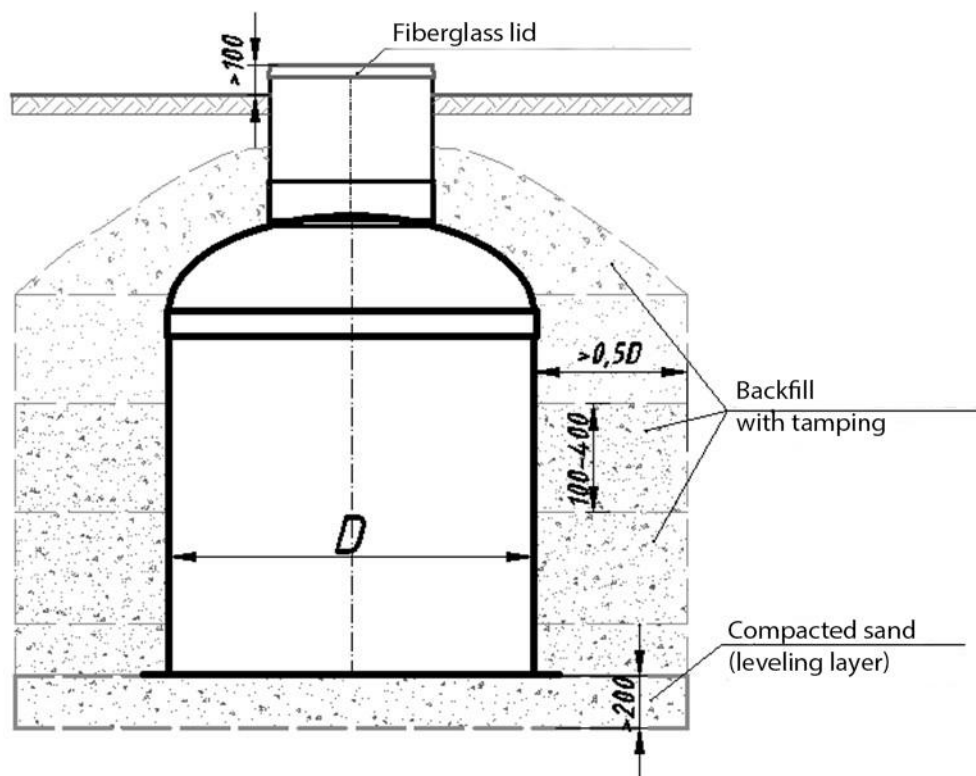

Fig.2 Installation diagram of the vertical body with low groundwater level

****Do not install Vertical products on unprepared ground (reinforced concrete slab or compacted sand).***

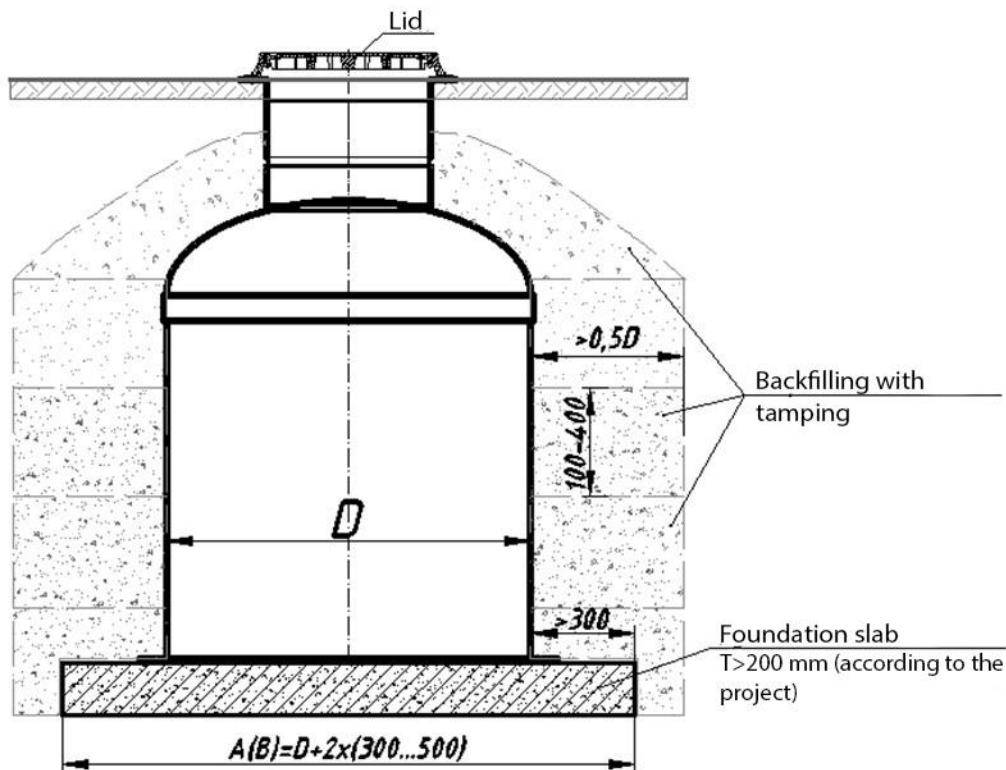
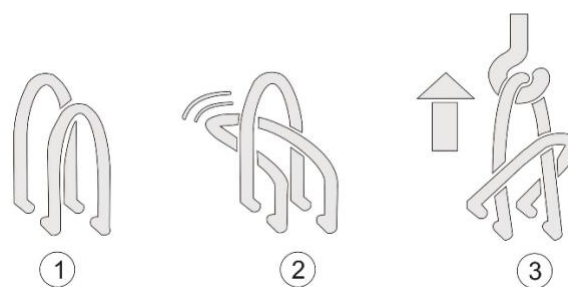

Fig.3 Scheme of installation of a vertical body with a high groundwater level*

- 3) Before installing the product in the pit, check for the absence of additional loose equipment inside the body, which was located inside during transportation and storage; inspect the mounting



hinges for defects or mechanical damage.

- 4) The equipment body is lifted by the mounting loops, and in the absence of such - use textile slings with even distribution of loads. To prevent pulling the mounting loop from under the fiberglass, you need to thread one end of the loop into the other, as shown in the figure.
- 5) Mount the enclosure according to the recommendations of the work project. Moving the product must be performed by specialized equipment (crane).

***The calculation of the loading reinforced concrete slab (Fig.3) and the method of attachment to it is carried out by a specialized design organization.**

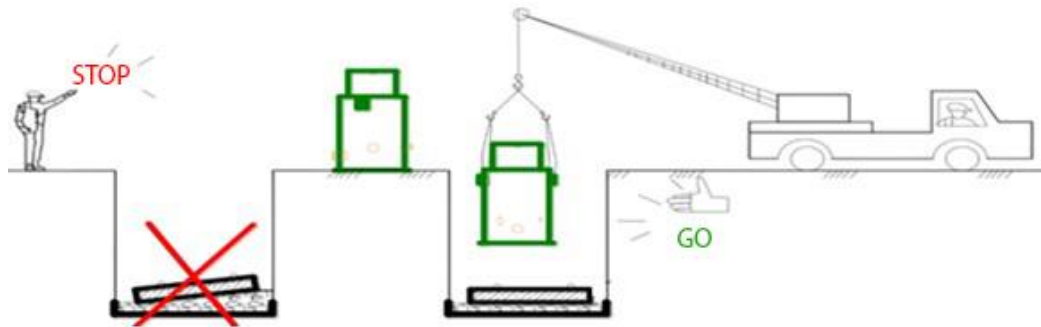

- 6) After installation, check the adhesion of the structure to the base. The enclosure should fit tightly to the base around the perimeter. In case of detection of a loose fit, the presence of stones and rubbish on the base, it is necessary: remove the rubbish and level the base using a cement mixture.
- 7) Perform verification of the product in plan and height. Check the verticality and horizontality of the installation.
- 8) If there is a possibility of flood or groundwater. Vertical structures are attached to the foundation slab by means of spacer anchors located around the perimeter. The type of anchors and the number of anchors depends on the groundwater level and the diameter of the body.

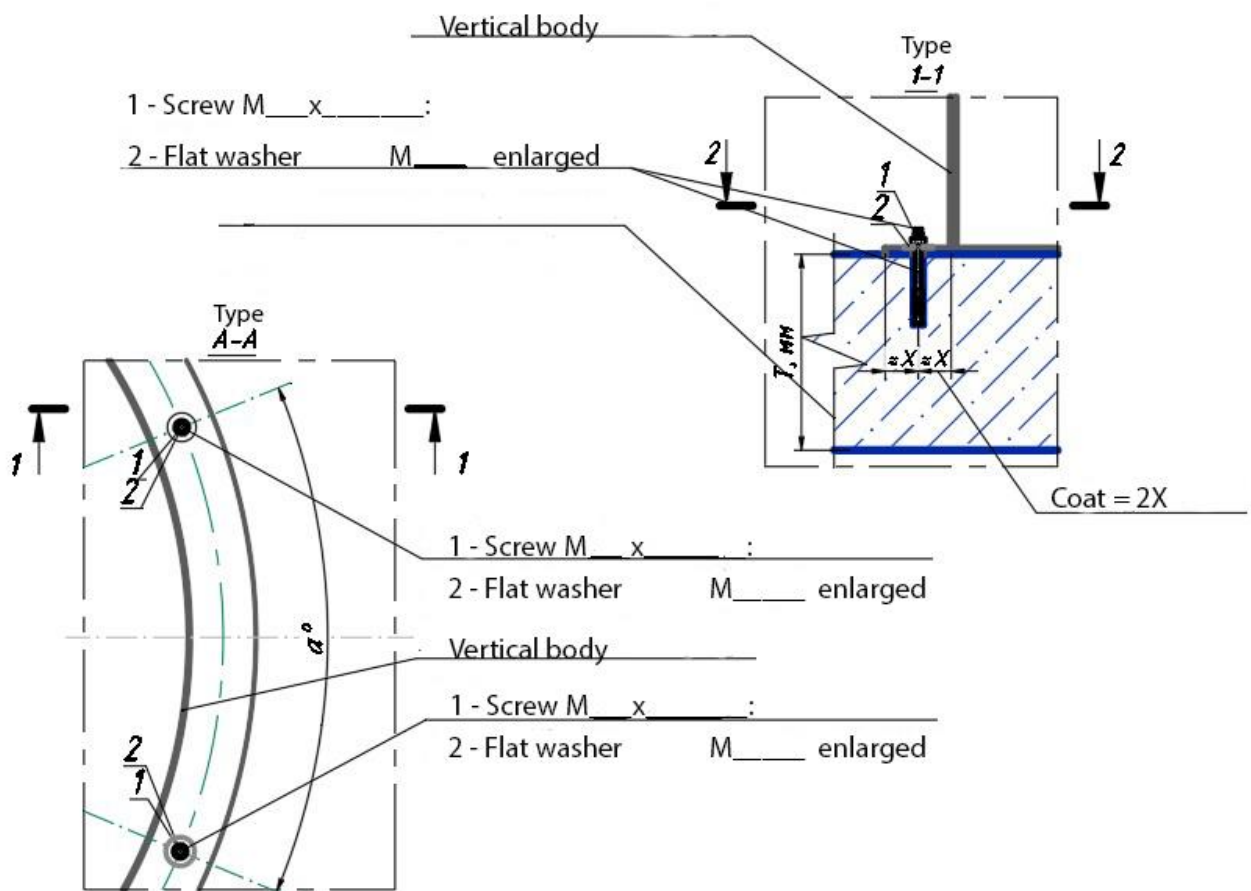

- 9) Start the backfilling process*.

- 10) Backfilling to the top of the pit should be carried out with sand without stones and inclusions with sharp edges with layer-by-layer compaction to the top of the pit with compaction $K > 0.95$ (up to the density of dry soil $\rho = 1.6...1.7 \text{ t/m}^3$).
- 11) It is recommended to backfill the equipment evenly around the perimeter with sand in layers of 100 - 300 mm or sand-cement mixture in layers of 400 - 500 mm.
- 12) Compaction of the backfill closer than 300 mm from the tank wall shall be performed with manual tamping machines** with special care to prevent damage to the walls of the structure. Do not allow the tamping equipment to come into contact with the fiberglass product. Combine compaction with water pouring. Water should be taken from the existing water supply or brought in.
- 13) After each layer of backfill, check the horizontal and vertical stability of the structure. Prevent displacement of the casing during backfilling.
- 14) **Backfill to a height of 1/3 of the height of the product**, compacting the space around the product in layers, paying special attention to the side and bottom of the product.
- 15) **Fill the product with water*** to a height of 1/3 of the product height**. The water level may differ from the backfill level by +/- 50-100mm.
- 16) **Backfill to a height of 1/2 of the product height and compact around the product**, paying particular attention to the sides and bottom of the product.
- 17) **Fill the product with water to a height of 1/2 the height of the product**. The water level may differ from the backfill level by +/- 50-100mm.
- 18) **Backfill to a height of 3/4 of the product height**, compressing the space around the product in layers, paying special attention to the side of the product.
- 19) **Fill the product with water to a height of 3/4 of the product height**. The water level may differ from the backfill level by +/- 50-100 mm.
- 20) **Backfill to the level of the upper pipes**. If there is a lower/outlet pipe, it must be connected to the pipeline/network, plug the area at the time of filling the product with water.
- 21) After filling the pit to the level of the inlet/outlet pipes, connect the upper pipelines, seal the joints. Pay special attention to the compaction of the soil under the pipelines to eliminate the possibility of damage.
- 22) Fill the tank with water to the level of the bottom of the upper pipes. This is the maximum water level in the tank, no further water filling is required.



****It is forbidden to backfill in the presence of snow, ice in the pit or use frozen backfill material.***

*****The use of mechanical vibrators weighing more than 100 kg is prohibited.***

******It is forbidden to install the tank without gradual filling of the tank with water. In this case, the manufacturer's warranty for the strength of the body and the operation of the structure does not apply.***

Incorrect!

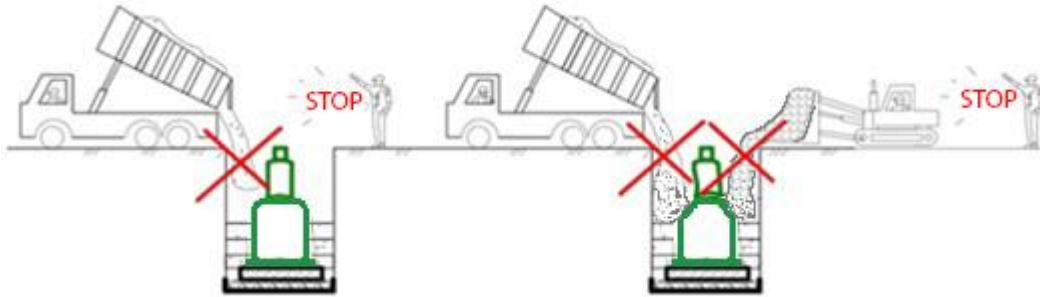

Correct!

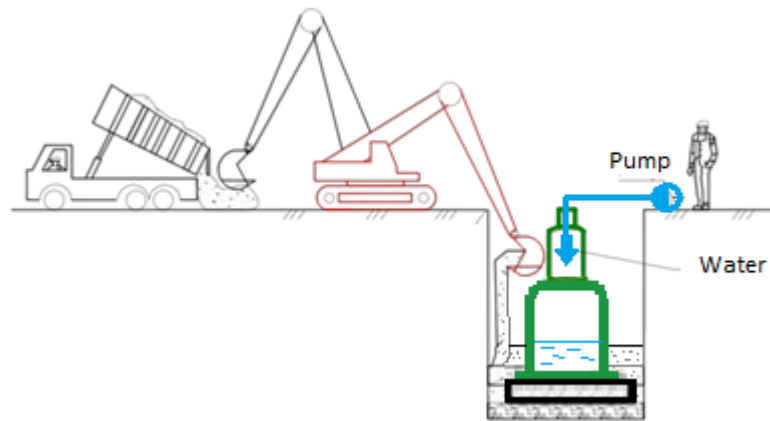

- 23) Installation of the neck (technical extension) is carried out after backfilling the body to the level of the place for installation of the neck / "saddle". Works on edging of the neck (if necessary) shall be agreed with the Manufacturer. In order to avoid the infiltration of ground, melt or storm water into the working container, the junction of the technical neck and the body must be degreased and sealed. It is recommended to use two-component adhesive or sealant for sealing and fixing.

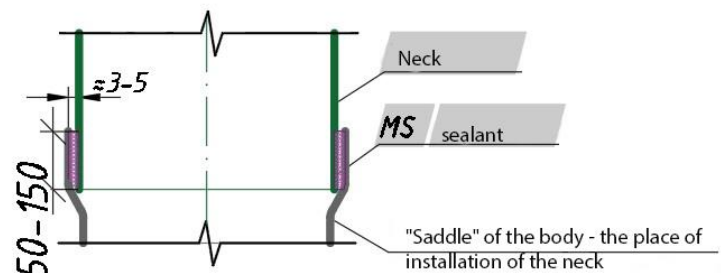
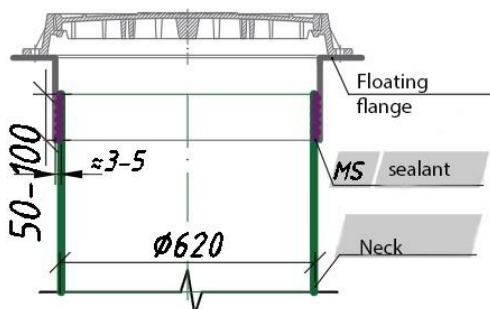

- 24) After the sealant has dried (approx. 3-4 hours), perform the final backfilling of the tank.
 25) Install the equipment supplied according to the order (ventilation pipes, ladder, sensors, etc.) in place.

- 26) To prevent accidental collision of vehicles on the location of the structure, set the danger zone at a distance of 1 m from the edges of the body around the perimeter.

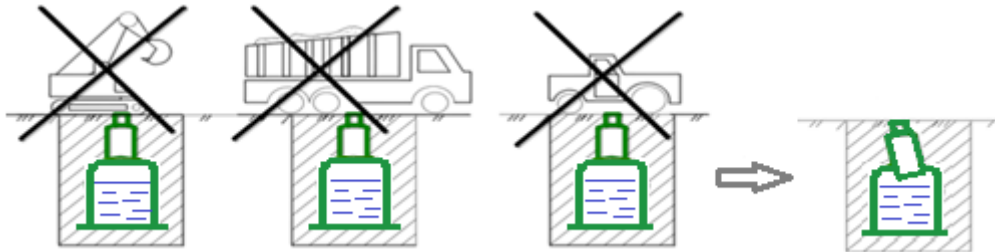

- 27) Vehicle access to the tank closer than 3 m must be carried out on the unloading* reinforced concrete slab.
- 28) The tank lid (or hatch) must protrude above ground level by: 50-70 mm - in the green adjacent zone; 100 mm - in the undeveloped, uninhabited zone; in the level with the coating - in the pedestrian zone and the zone of traffic.
- 29) When installing the tank under the carriageway, to distribute the loads, a reinforced concrete unloading slab* shall be mounted or poured over the structure.

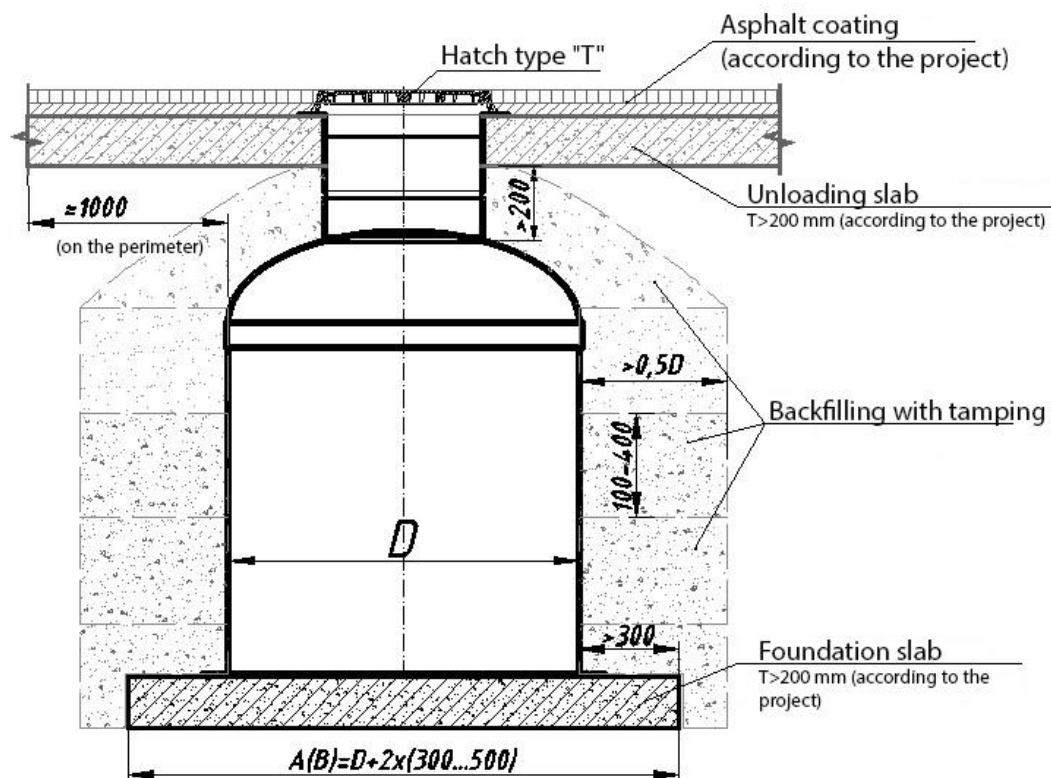

Fig. 4 Layout of the vertical housing in the area of transport collision

- 30) In case of temporary suspension of installation works, measures shall be taken to prevent foreign objects from entering the construction site, especially into the tank.

**The calculation of the unloading reinforced concrete slab is performed by a specialized design organization.*

Performance of works in winter period:



installation at the average daily temperature below $+5^{\circ}\text{C}$ and the minimum daily temperature below 0°C is performed in accordance with the instructions of this section.

1) Hydrological conditions: a) the average daily air temperature shall not be lower than minus 10°C ; b) wind speed shall not exceed 5 m/s; c) the water area shall be free of solid broken ice.

2) Avoid hitting the tanks during storage at sub-zero temperatures;

3) Prevent soil freezing: to facilitate soil development in

winter, it is advisable to protect soils from freezing BEFORE the onset of frost. Thermal insulation cover of the soil surface can be provided in the following ways:

- Covering the surface with various heaters: mineral wool, expanded polystyrene, polyethylene foam, polyurethane foam - in several layers (approx. 100-100mm); straw, peat, sawdust - 100-300mm;
 - Soaking the soil with salt solutions - calcium chloride, sodium chloride (0.5-1.0 kg of salts per 1 m³ of soil);
 - Snow cover retention;
 - Installation of heating devices;
 - Other available methods and materials at the site.
- 4) Tamping of pits should be carried out when the soil is thawed. Soil freezing from the surface is allowed to a depth of not more than 20 cm.
 - 5) Measurement of the temperature of the base, with the measurement of the depth of excavation and the thickness of the remaining layer at least twice per shift;
 - 6) In case of temperature drop or interruptions in work, prepared but not compacted areas of the excavation should be covered with heat-insulating materials or loose dry soil.
 - 7) At high groundwater levels, the water level in the excavation and trenches should be maintained at the same level;
 - 8) When immersing tanks, it is possible to use solutions with a reduced freezing point that do not have a harmful aggressive effect on structures, as well as take measures to prevent freezing of tanks to the ground.
 - 9) Backfilling should be performed with frozen sand with compaction and water spillage. Frozen sand (soil, other backfill agreed with the manufacturer) should be removed from the surface of the design profile of embankments before backfilling (no ice layers and lenses).
 - 10) Compaction of the soil by tamping is allowed when the soil is not frozen and has natural moisture. The required depth of compaction at soil moisture below the optimum is achieved by increasing the weight, diameter or height of the rammer discharge;
 - 11) DO NOT leave a half-filled container with water without insulation with a heat-insulating layer.

6. SAFETY GUIDELINES

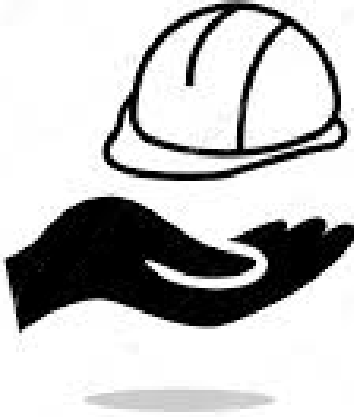

During the installation and operation of the structure, it is necessary to be guided by the provisions and requirements established by the following documents*:

- State Building Code A.3.2-2-1009 "Occupational health and safety in construction";
- State Building Code C. 2.1-10-1009 "Foundations and bases of structures".
- "Rules of technical operation of water supply and sewerage systems in settlements of Ukraine";
- "Labor protection and safety in public utilities";

And other regulatory documents in force on the territory, object, country of construction.



Installation and assembly of the system should be carried out by a specialized installation team under the supervision of a technical specialist who is familiar with the above documents, with the technical passport and wiring diagram (if available).

Personnel must be provided with personal protective equipment, serviceable tools, devices and mechanisms, as well as overalls and safety shoes in accordance with applicable standards.

It is forbidden to use open fire, smoke, use devices without explosion protection when lowering into the structure.

It is allowed to go down into the oil separator only after its prolonged ventilation with open lids (at least 1 hour in the absence of

a gas analyzer) in compliance with the rules of maintenance of sewer wells.

7. WARRANTY OBLIGATIONS



The manufacturer guarantees the warranty period for the operation of the Vodaland **OilBase100** oil and sand separator with a sludge chamber, provided that the consumer complies with the operating, transportation and storage conditions established by this Technical Passport.

Warranty period of operation - **2 (two) years** from the date of commissioning, but not more than 3 years from the date of delivery.

The projected service life of Vodaland vessels is **50 years** from the date of commissioning.

The warranty period for the installation work is set by the organization that performed them.

The warranty conditions are preserved in case:

- 1) The body of the structure is installed on a prepared base according to the design decision and recommendations of this passport.
- 2) Backfilling is made in layers with sand or cement-sand mixture with simultaneous filling with water to balance the external and internal loads on the building.
- 3) Construction and other rubbish did not get inside the casing.
- 4) Correct connection of equipment and pipelines is ensured.
- 5) The operation of the structure meets the requirements of the technical passport.
- 6) The amount and parameters of wastewater are in accordance with the project.

The warranty does not apply:

- 1) In case of damage received during transportation and unloading;
- 2) In case of damage received during installation and connection;
- 3) In case of damage caused during operation, which did not meet the necessary requirements specified in the technical passport and other technical documentation received at the time of purchase.
- 4) In case of repair or attempts to repair the structure by individuals (organizations) without the consent of the Manufacturer.
- 5) The manufacturer is not responsible under the warranty conditions in case of use of the equipment for other purposes.

The warranty case is determined by the specialists of the manufacturer FIBERIKA LLC and the representative of the organization that supplied the equipment.

8. TRANSFER ACCEPTANCE CERTIFICATE

Separator of oil products and sand Vodaland Oilbase100 (OB1)

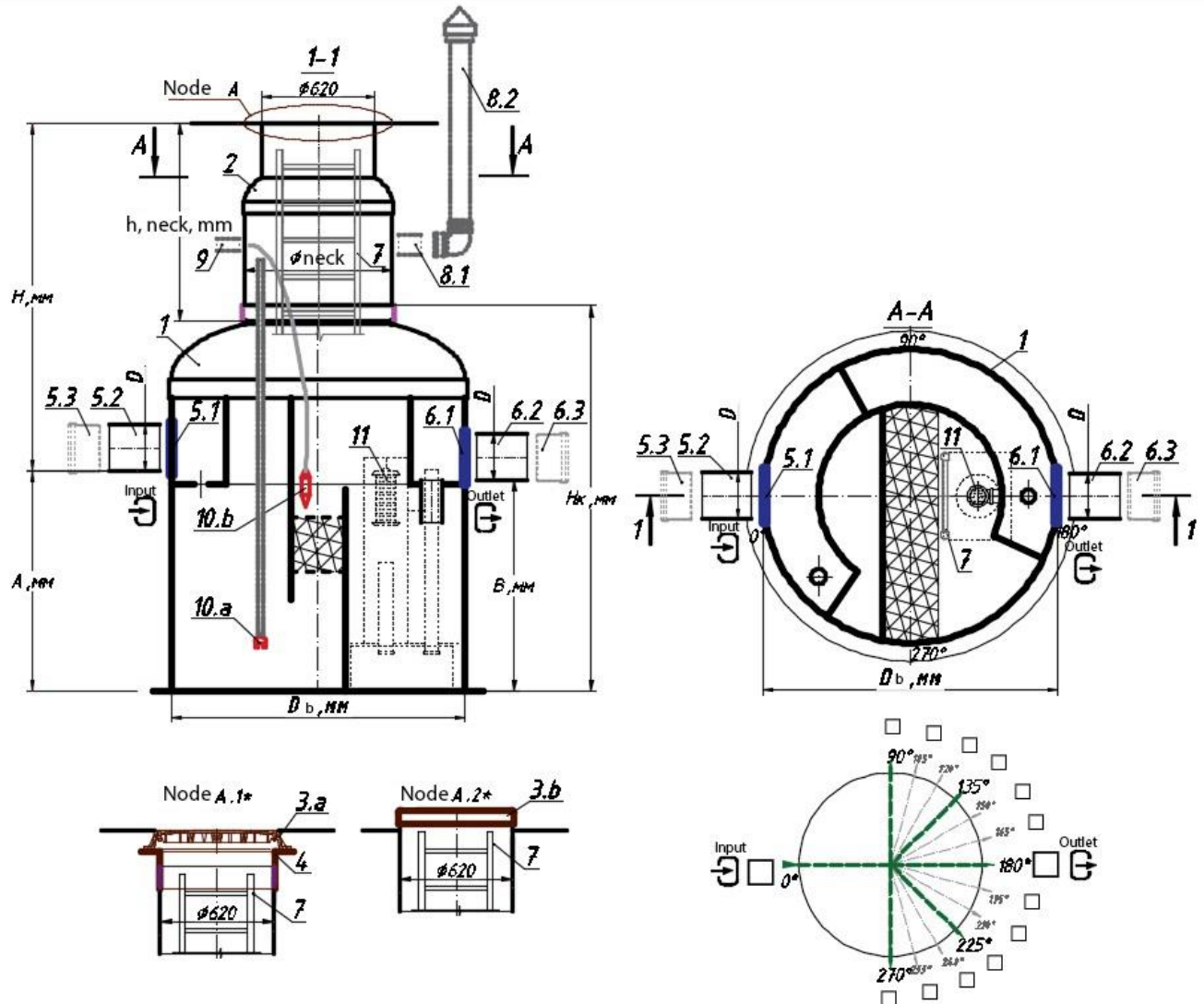

Fig. 5 Scheme of OilBase100 oil and sand separator (OB1)

- 1-body**;
- 2-process neck;
- 3a-hatch;
- 3b-lid;
- 4-floating neck flange;
- 5-inlet pipe (5.1 rubber seal; 5.2 pipe; 5.3 socket / coupling);
- 6-outlet pipe (6.1 rubber seal; 6.2 pipe; 6.3 socket / coupling);
- 7- universal ladder;
- 8- ventilation (8.1 vent pipe; 8.2 pipe with fungus);
- 9- pipe / gland for the input of electric cables;
- 10.a-sludge level sensor;
- 10.b-oil product level sensor;
- 11- locking device (float).

Pos. 7 - 11 - not included in the standard package of the product, installed at the request of the Customer.

***The original Technical Passport is issued in one copy upon shipment and cannot be restored!!!**
**** Allowable deviation during the manufacture of products is up to 1-3%.**

Table.1 Equipment set (See the diagram, select the necessary / unnecessary cross out)

No	Product name	Num, pcs.	Note
1	2	3*	4
Separator of oil products and sand Vodaland OilBase100 - ___/___, capacity ___ l/s, fiberglass		Product No. _____	
1	Fiberglass casing Dbody=_____ mm, Hbody =_____, mm Depth of the inlet pipe H = _____ mm	1	Vertical
2	Technological extension (neck): d=620 / 800x620 / 1000x620 mm, hneck=_____, mm	___/___/___	
3	a) Hatch type: "A15 / C250 / D400 / Garden plastic" b) Fiberglass lid: d=620 / 800 / 1000 / _____ mm etc. _____	___/___/___ ___/___/___	
4	Floating neck flange: d=620 / 800 / 1000 mm, h=100 / _____ mm	___/___/___	
5	Inlet (supply) pipe D(DN)_____: A-binding of the pipe: _____ mm 5.1 - rubber seal for D _____ 5.2 - PVC socket SN4 / _____ 5.3 - PVC coupling/socket SN4 / _____ etc. _____	_____ _____ _____ _____	
6	Outlet (discharge) pipe D(DN)_____: B-binding of the outlet pipe: _____ mm 6.1 - rubber seal for D _____ 6.2 - PVC socket SN4 / _____ 6.3 - coupling / socket PVC SN4 / _____ etc. _____	_____ _____ _____ _____	
7	Universal ladder Aluminum / Stainless steel L=_____ r.m.	___/___	
8	Ventilation pipe-d: 8.1- rubber seal for D110 + PVC pipe SN4 D110 / _____; 8.2 - rubber seal + PVC pipe-d SN4 D110 (____), L=1(____) r.m.; baffle D110(____)	_____ _____	
9	Connector for the input of electric cables: 9.1 - oil seal _____; 9.2 - rubber seal + PVC pipe-d SN4 D110 (____)	_____ _____	
10	Sediment control system: a) Sludge level sensor _____ b) Oil product level sensor _____ c) Universal alarm _____	_____ _____ _____	
11	Shut-off device DN(D)=	<u>1</u>	
12	<u>Product passport*</u>	<u>1</u>	
13	Anchors _____	_____	
14	Sealant _____ ml	_____	

* if Col.3 is not filled in, it means that the item is not included in the package (not shipped).

« _____ » _____ 20____. _____
Date **Manufacturer Place of Seal**

Goods and Technical passport checked and shipped

« _____ » _____ 20____. _____
Date **Name / signature Supplier**

The goods and the Technical Passport have been checked and handed over

« _____ » _____ 20____. _____
Date **Name / signature of the Customer**

The goods and the Technical Passport have been checked and received

Warranty card No. 1
Place of Seal of the Manufacturer

Description of the claimed fault and repair
Service protocol No. ___ of ___ / ___ / ___
Date of Issue. Signature of the Client:
Remarks:
Signature and seal of the service organization
Service engineer: _____ / _____ (name) (signature)
Head of the service organization: _____ / _____ (name) (signature)
Notes:

Warranty card No. 2
Place of Seal of the Manufacturer

Description of the claimed fault and repair
Service protocol No. ___ of ___ / ___ / ___
Date of Issue. Signature of the Client:
Remarks:
Signature and seal of the service organization
Service engineer: _____ / _____ (name) (signature)
Head of the service organization: _____ / _____ (name) (signature)
Notes:

Table.2 Equipment set (See the diagram, select the necessary / unnecessary cross out)

No	Product name	Num, pcs.	Note
1	2	3*	4
Separator of oil products and sand Vodaland OilBase100 - ___/___, capacity ___ l/s, fiberglass		Product No.	
1	Fiberglass casing Dbody=_____ mm, Hbody =_____, mm Depth of the inlet pipe H = _____ mm	1	Vertical
2	Technological extension (neck): d=620 / 800x620 / 1000x620 mm, hneck=_____, mm	___/___/___	
3	a) Hatch type: "A15 / C250 / D400 / Garden plastic" b) Fiberglass lid: d=620 / 800 / 1000 / _____ mm etc.	___/___/___ ___/___/___	
4	Floating neck flange: d=620 / 800 / 1000 mm, h=100 / _____ mm	___/___/___	
5	Inlet (supply) pipe D(DN)_____: A-binding of the pipe: _____ mm 5.1 - rubber seal for D _____ 5.2 - PVC socket SN4 / _____ 5.3 - PVC coupling/socket SN4 / _____ etc.	_____ _____ _____	
6	Outlet (discharge) pipe D(DN)_____: B-binding of the outlet pipe: _____ mm 6.1 - rubber seal for D _____ 6.2 - PVC socket SN4 / _____ 6.3 - coupling / socket PVC SN4 / _____ etc.	_____ _____ _____	
7	Universal ladder Aluminum / Stainless steel L=_____ r.m.	___/___	
8	Ventilation pipe-d: 8.1- rubber seal for D110 + PVC pipe SN4 D110 /_____; 8.2 - rubber seal + PVC pipe-d SN4 D110 (___), L=1(____) r.m.; baffle D110(____)	_____ _____	
9	Connector for the input of electric cables: 9.1 - oil seal _____; 9.2 - rubber seal + PVC pipe-d SN4 D110 (____)	_____ _____	
10	Sediment control system: a) Sludge level sensor _____ b) Oil product level sensor _____ c) Universal alarm _____	_____ _____ _____	
11	Shut-off device DN(D)=	<u>1</u>	
12	Product passport*	<u>1</u>	
13	Anchors _____	_____	
14	Sealant _____ ml	_____	

* if Col.3 is not filled in, it means that the item is not included in the package (not shipped).

« _____ » _____ 20____.

Date

Name / signature **Supplier**

The goods and the Technical Passport have been checked and handed over

« _____ » _____ 20____.

Date

Name / signature of the **Customer**

The goods and the Technical Passport have been checked and received

Tear-off sheet (remains with the Supplier)

Actual certificates can be requested from the Supplier!



ОРГАН З СЕРТИФІКАЦІЇ ТОВ «ТЕСТМЕТРСТАНДАРТ»
Україна, 10003, м. Житомир, майдан Перемоги, 10

СЕРТИФІКАТ ВІДПОВІДНОСТІ

Зареєстровано в Реєстрі ОС за № UA.P.000442-22

Термін дії з 05 вересня 2022 р. до 04 вересня 2023 р.

Продукція Сепаратори нафтопродуктів і піску Oil, комбіновані системи
очистки OilAbsorb, сорбційні фільтри Absorb, колодязі
каналізаційні Well, сепаратори жиру Grease (згідно додатку)

28.29.12
код ДКПП

код УКТ ЗЕД

Відповідає вимогам ТУ У 28.2-44796077-001:2022 «Системи очищування, накопичення та транспортування водостоків: поверхневих, господарсько-побутових стічних вод та технічних рідин систем каналізації, а також водопроводу та технічних рідин, близьких за якістю. Технічні умови». (пп. 3.2.1.1 (табл. 12), 3.2.1.4, 3.2.2.2, 3.2.2.6, 3.2.2.7.)

Виробник продукції ТОВ «ФІБЕРІКА», Україна, 18028, м. Черкаси, вул. Різдвяна, 290, код ЄДРПОУ 44796077

Сертифікат видано ТОВ «ФІБЕРІКА», Україна, 18028, м. Черкаси, вул. Різдвяна, 290, код ЄДРПОУ 44796077

Додаткова інформація Продукція, яка виготовляється серійно з 05.09.2022 р. до 04.09.2023 р.
Технічний нагляд один раз на рік

Сертифікат видано органом з сертифікації Орган з сертифікації продукції
ТОВ «Тестметрстандарт», 10003, м. Житомир,
майдан Перемоги, 10.

На підставі Лабораторія випробувань і надійності ПРИВАТНОГО АКЦІОНЕРНОГО ТОВАРИСТВА
«ВІННИЦЬКИЙ ЗАВОД «МАЯК», атестат акредитації №20208 – протокол №117-2022 від
04.09.2022 р.

Заступник керівника органу з сертифікації



М.П.

підпис

Леонід ЛАБУНЕЦЬ

ініціали, прізвище

№ 006496

Чинність сертифіката можна перевірити
за тел.: (0412) 43-30-20

Actual certificates can be requested from the Supplier!



ОРГАН З СЕРТИФІКАЦІЇ ТОВ «ТЕСТМЕТРСТАНДАРТ»
Україна, 10003, м. Житомир, майдан Перемоги, 10

СЕРТИФІКАТ ВІДПОВІДНОСТІ

Зареєстровано в Реєстрі ОС за № UA.P.000442-22

Термін дії з 05 вересня 2022 р. до 04 вересня 2023 р.

Сепаратори нафтопродуктів і піску Oil
Комбіновані системи очистки OilAbsorb
Сорбційні фільтри Absorb
Колодязі каналізаційні Well
Сепаратори жиру Grease

№ п/п	Категорії виробів	Назва виробів	Артикул
1	Сепаратори нафтопродуктів Oil:		
	Сепаратори нафтопродуктів і піску без поплавка, вертикальні	OilEasy0	OE0
		OilEasy200	OE1
		OilEasy700	OE2
	Сепаратори нафтопродуктів і піску з поплавком, вертикальні	OilBase0	OB0
		OilBase200	OB1
		OilBase700	OB2
	Сепаратори нафтопродуктів без поплавка, горизонтальні	OilEasyH0	OEH0
		OilEasyH200	OEH1
		OilEasyH700	OEH2
		OilEasyH1300	OEH3
	Сепаратори нафтопродуктів і піску з поплавком, горизонтальні	OilBaseH0	OBH0
		OilBaseH200	OBH1

Заступник керівника органу з сертифікації

підпис

Леонід ЛАБУНЕЦЬ

ініціали, прізвище

Серія TMC



№ 006497

Чинність сертифіката можна перевірити за тел.: (0412) 43-30-20



VODALAND

Kyiv

Kyiv, 67 Peremohy Ave. building "K"
+38 (044) 339-95-59
info@vodaland.com.ua

Odesa

21/49 Bugayevskaya str., office 45
+38 (048) 734-23-26
odessa@vodaland.com.ua

Dnipro

29 Pastera St., office 401
+38 (056) 733-95-04
dnepr@vodaland.com.ua

Lviv

359 Gorodotska street
+38 (032) 242 15 86
lviv@vodaland.com.ua

Kharkiv

20, O. Matrosova St., office. 1
+38 (057) 721-04-43
kharkov@vodaland.com.ua

Ternopil

44 Brodovskaya St., office 13
+38 (0352) 43-00-22
ternopil@vodaland.com.ua

Republic of Moldova

VAMORA GRUP S.R.L.
str.Uzinelor 169
MD-2023 mun.Chisinau

Romania

str. Preciziei nr. 3F, Sector 6,
București 062202
+40 31 437 0308

United States of Amerika

4334 Rider Trail S, Earth City, MO 63045,
[1 636-940-4020](tel:16369404020)

