

Primary Usage

Reference No.

Sign. and date

Copy inv. No.

Repl. Inv. No.

Sign. and date

Orig. Inv. No.

10" Polymer Concrete Sand Trap

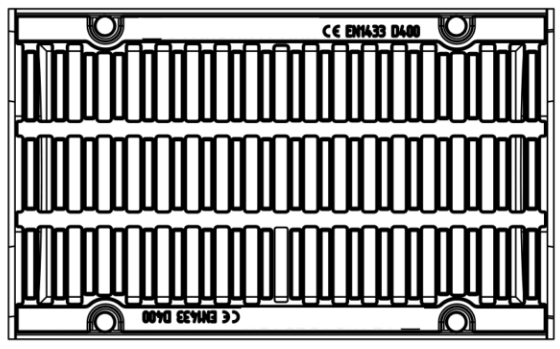
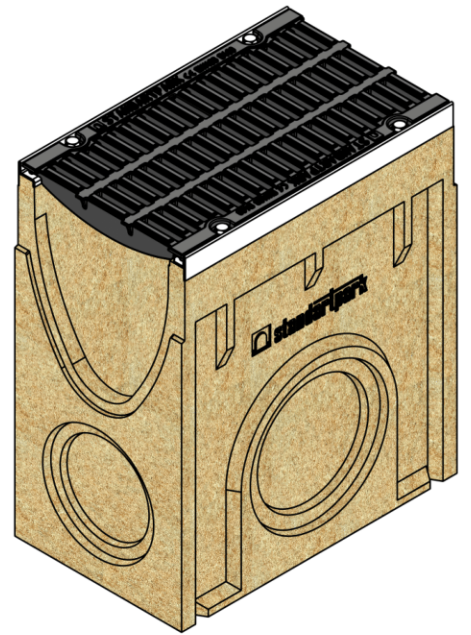
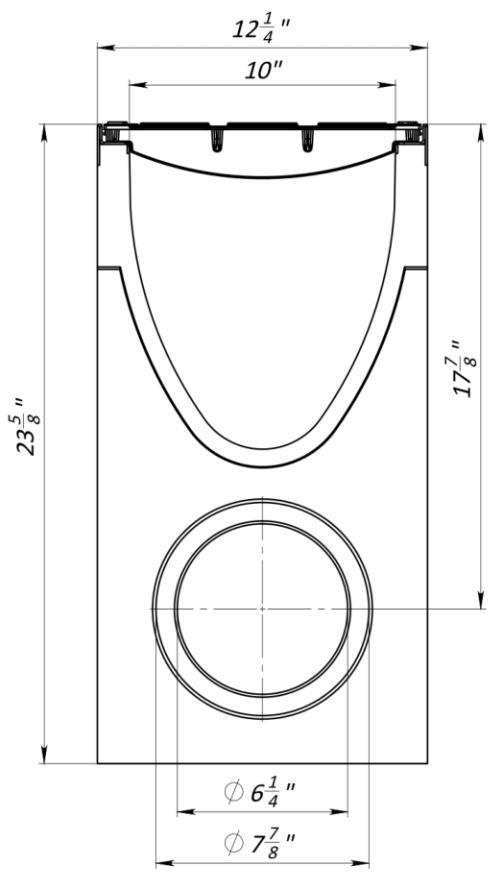
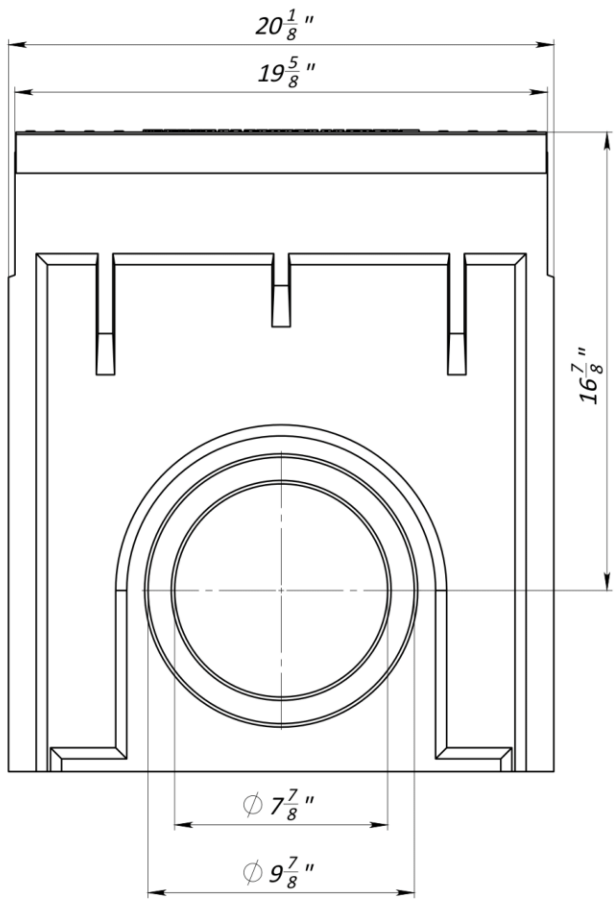

- 1. Area of water intake slots 68 sq in
- 2. Deviation of the actual weight of the nominal can be up to 10%

				Art. 076871334			
				10" Polymer Concrete Sand Trap			
Rev.	Sheet	Doc. No.	Sign.	Data	Let.	Weight (lb)	Scale
				11.09.18		131.8	1:5
					076871334		
					Load Class D		
					Sheet	Sheets 1	
					Polymer Concrete, Steel, Ductile Cast Iron		