

Primary Usage

Reference No.

Sign. and date

Copy inv. No.

Repl. Inv. No.

Sign. and date

Orig. Inv. No.

4" Stainless Steel Revision Wall Slot Drain

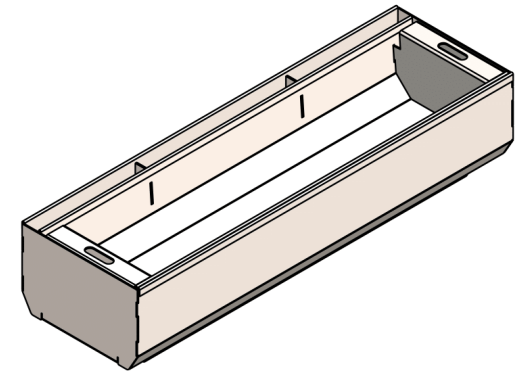
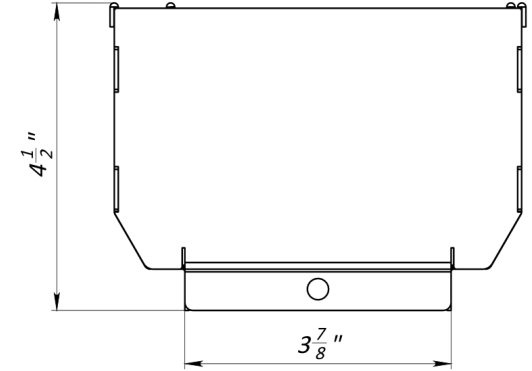
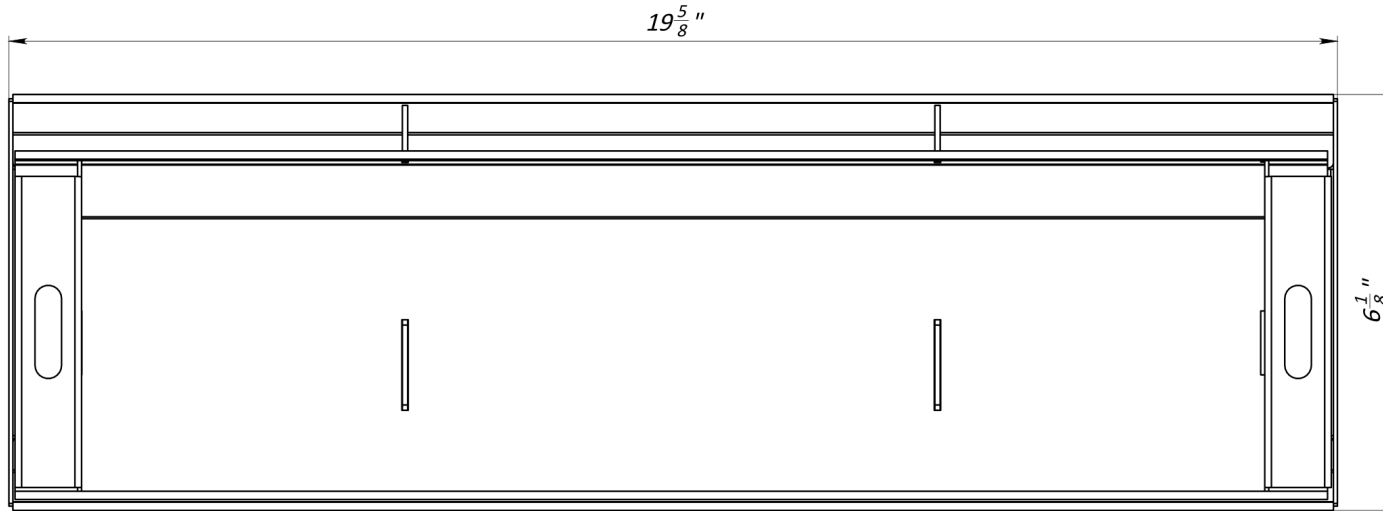
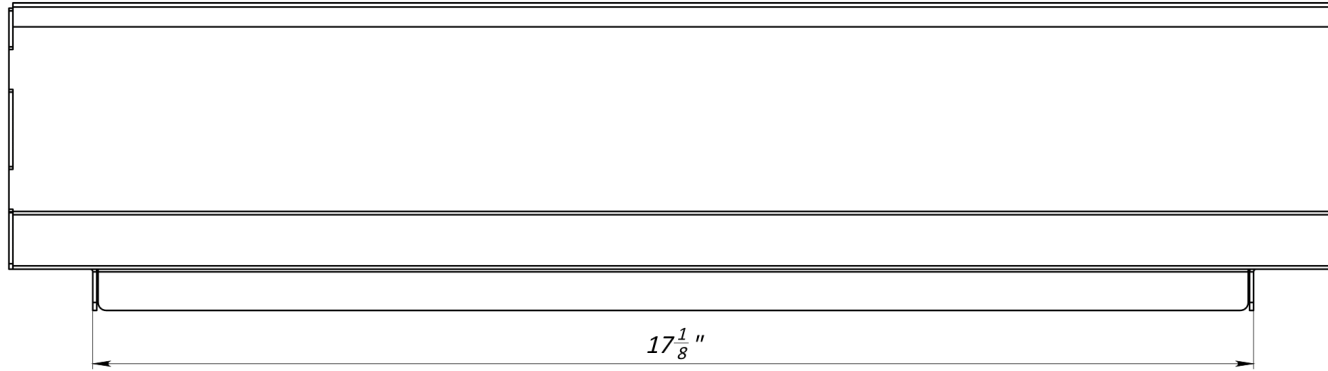

- 1. Area of water intake slots 13 sq in
- 2. Deviation of the actual weight of the nominal can be up to 10%

				Art. 20975-1L-100			
				4" Stainless Steel Revision Wall Slot Drain			
Rev.	Sheet	Doc. No.	Sign.	Data	Let.	Weight (lb)	Scale
				11.09.18		9.47	1:2
					Sheet		Sheets 1
					Stainless Steel		VODALAND