

1. *Dimensions for reference*
2. *Delivery and packaging are carried out in accordance with the terms of the contract*
3. *The manufacturer reserves the right, without notice to the consumer, to make changes to the design of the products for improvement of their technological and operational parameters, which will not affect the quality and properties of the product.*

UNLESS OTHERWISE SPECIFIED: DIMENSIONS ARE IN MILLIMETERS SURFACE FINISH: TOLERANCES: ISO 2768-m LINEAR: ANGULAR:		FINISH:		DEBURR AND BREAK SHARP EDGES		DO NOT SCALE DRAWING		REVISION	
DRAWN Halushka		SIGNATURE		DATE 04.08.22		 <b>Stainless Steel End Cap for Slot module system Type A</b>			
CHK'D Karetin									
APPV'D									
MFG									
Q.A									
				MATERIAL: Stainless Steel (AISI 304)		ARTICLE: 992101		A3	
				WEIGHT: 0.11 kg		SCALE:1:5		SHEET 1 OF 4	

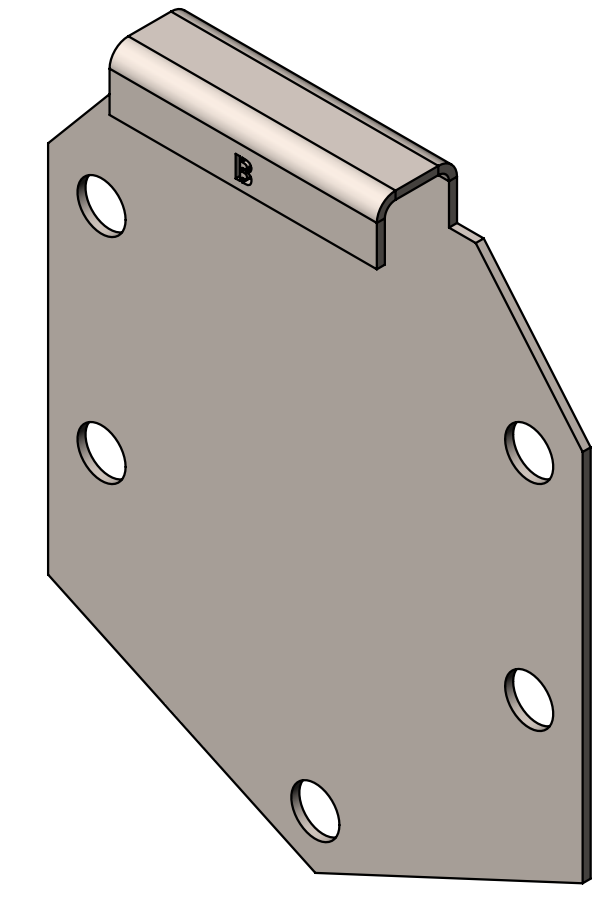
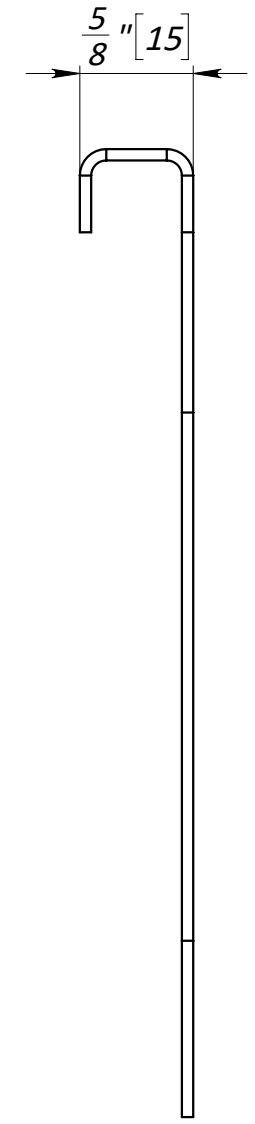
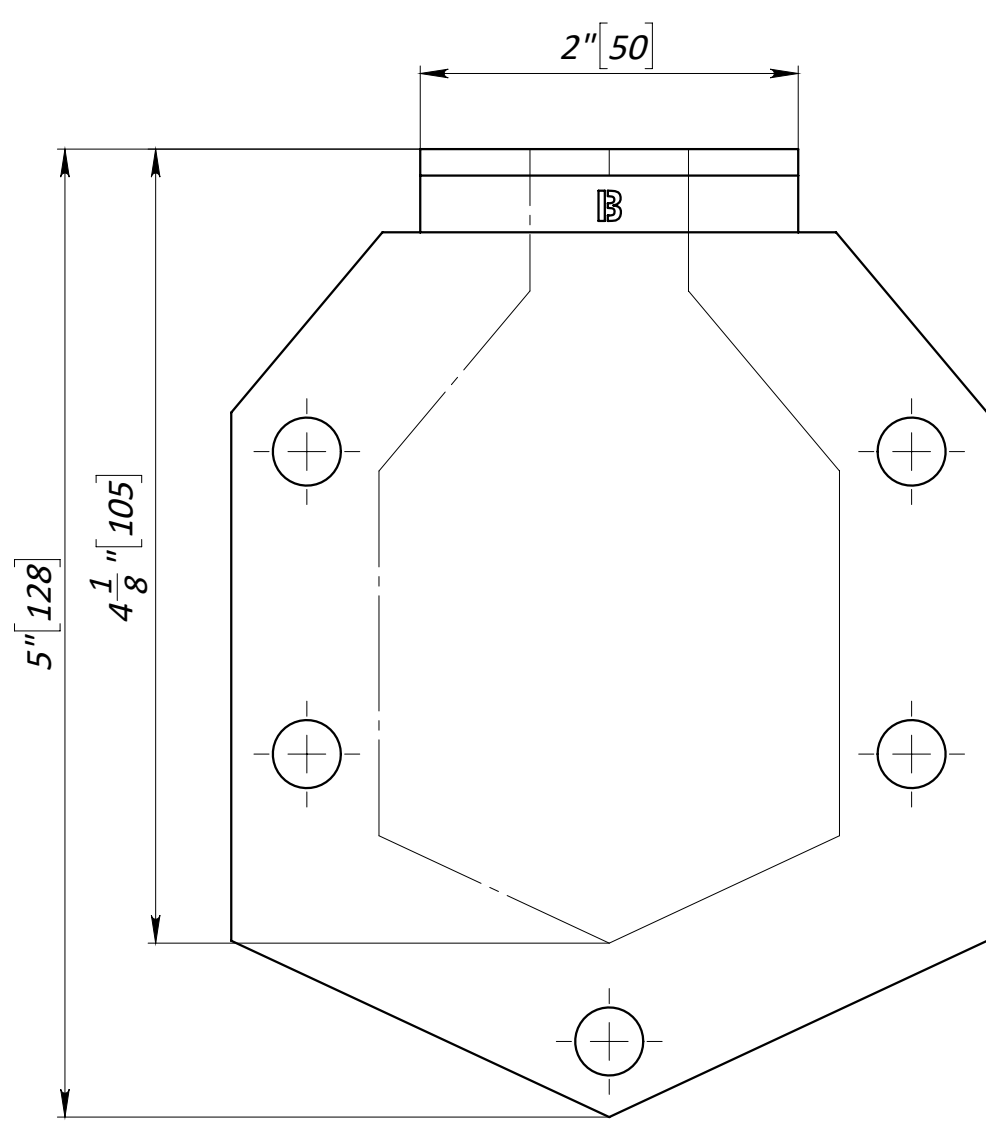

1. Dimensions for reference
2. Delivery and packaging are carried out in accordance with the terms of the contract
3. The manufacturer reserves the right, without notice to the consumer, to make changes to the design of the products for improvement of their technological and operational parameters, which will not affect the quality and properties of the product.

UNLESS OTHERWISE SPECIFIED: DIMENSIONS ARE IN MILLIMETERS SURFACE FINISH: TOLERANCES: ISO 2768-m LINEAR: ANGULAR:		FINISH:		DEBURR AND BREAK SHARP EDGES		DO NOT SCALE DRAWING		REVISION	
DRAWN		SIGNATURE		DATE		TITLE:			
Галушка				04.08.22		Stainless Steel End Cap for Slot module system Type B			
CHK'D		SIGNATURE		DATE		ARTICLE:		A3	
Каретін						992102			
APPV'D		SIGNATURE		DATE		MATERIAL:		SCALE:1:5	
						Stainless Steel (AISI 304)		SHEET 2 OF 4	
MFG		SIGNATURE		DATE		WEIGHT: 0.11 kg			
						0.11 kg			
Q.A		SIGNATURE		DATE					

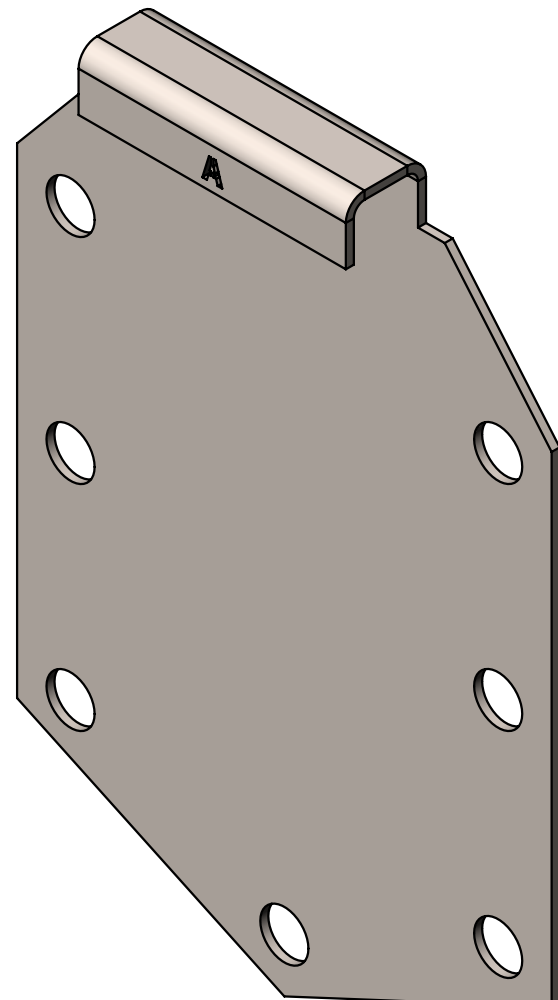
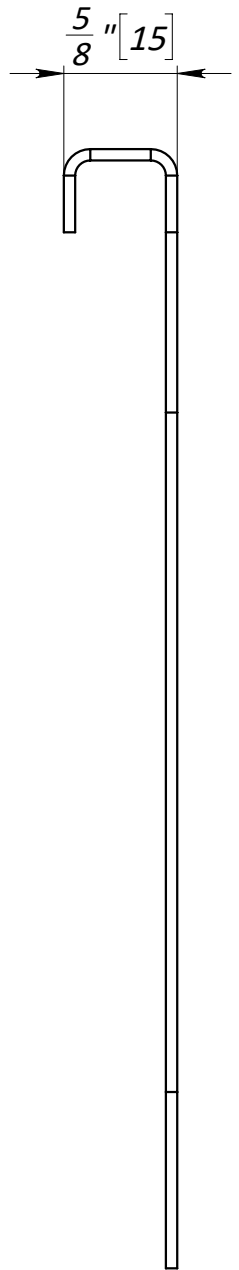
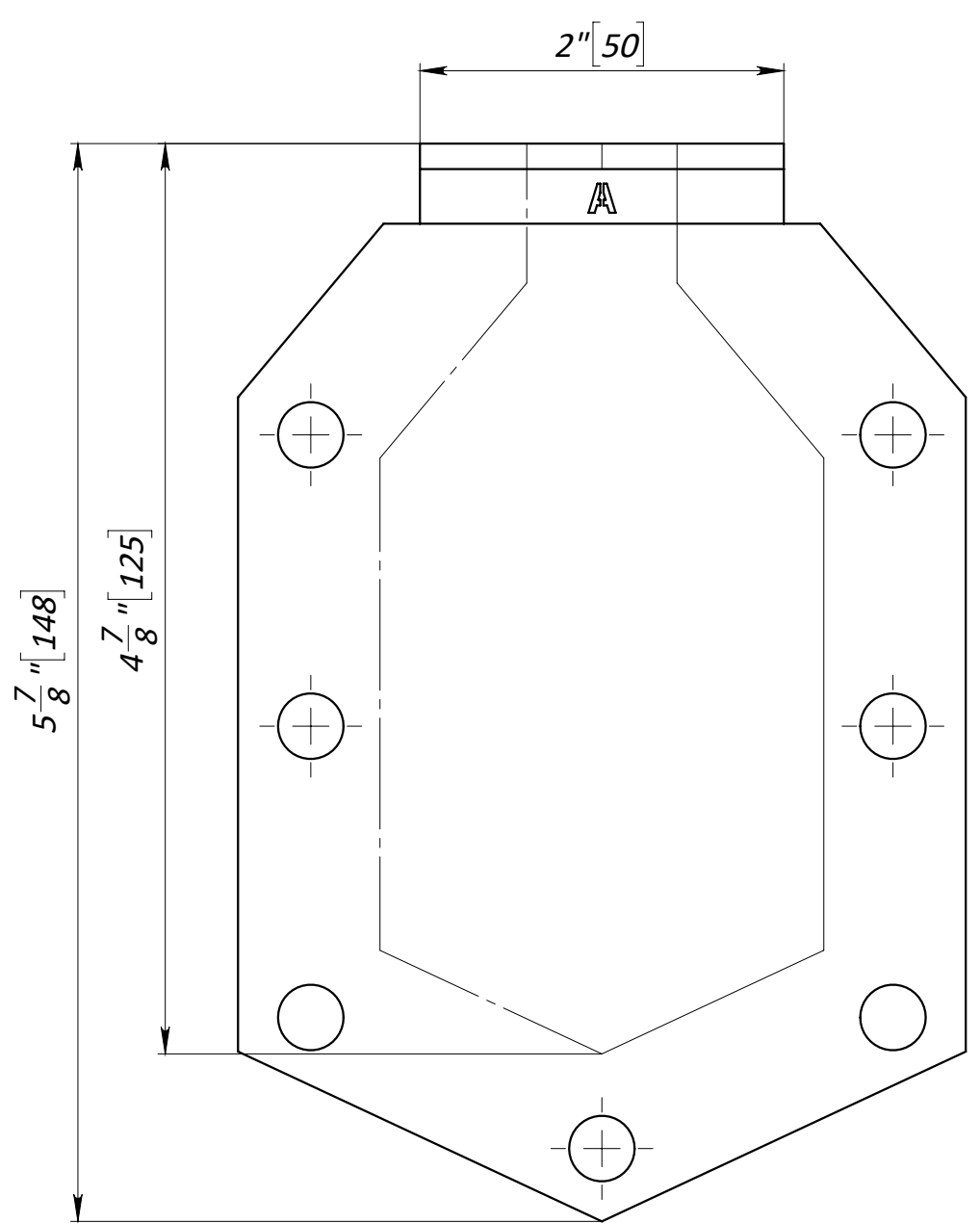

1. Dimensions for reference
2. Delivery and packaging are carried out in accordance with the terms of the contract
3. The manufacturer reserves the right, without notice to the consumer, to make changes to the design of the products for improvement of their technological and operational parameters, which will not affect the quality and properties of the product.

UNLESS OTHERWISE SPECIFIED: DIMENSIONS ARE IN MILLIMETERS SURFACE FINISH: TOLERANCES: ISO 2768-m LINEAR: ANGULAR:		FINISH:	DEBURR AND BREAK SHARP EDGES	DO NOT SCALE DRAWING	REVISION
DRAWN Галушка		SIGNATURE	DATE 04.08.22	 <b>Stainless Steel End Cap for Slot module system Type C</b>	
CHK'D Каретін					
APPV'D					
MFG					
Q.A				MATERIAL: Stainless Steel (AISI 304)	ARTICLE: 992103
				WEIGHT: 0.11 kg	A3
				SCALE: 1:5	SHEET 3 OF 4

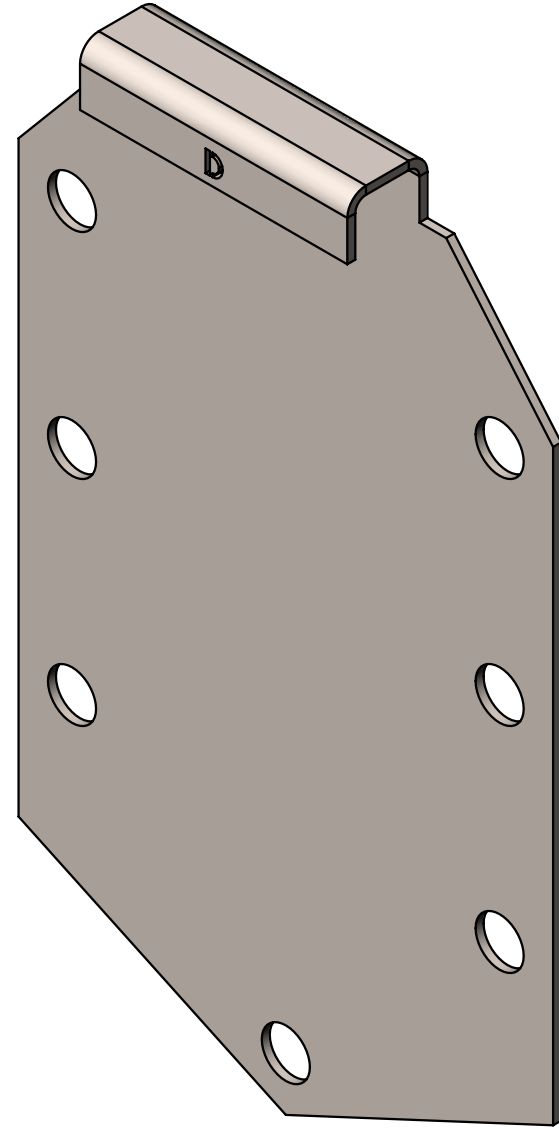
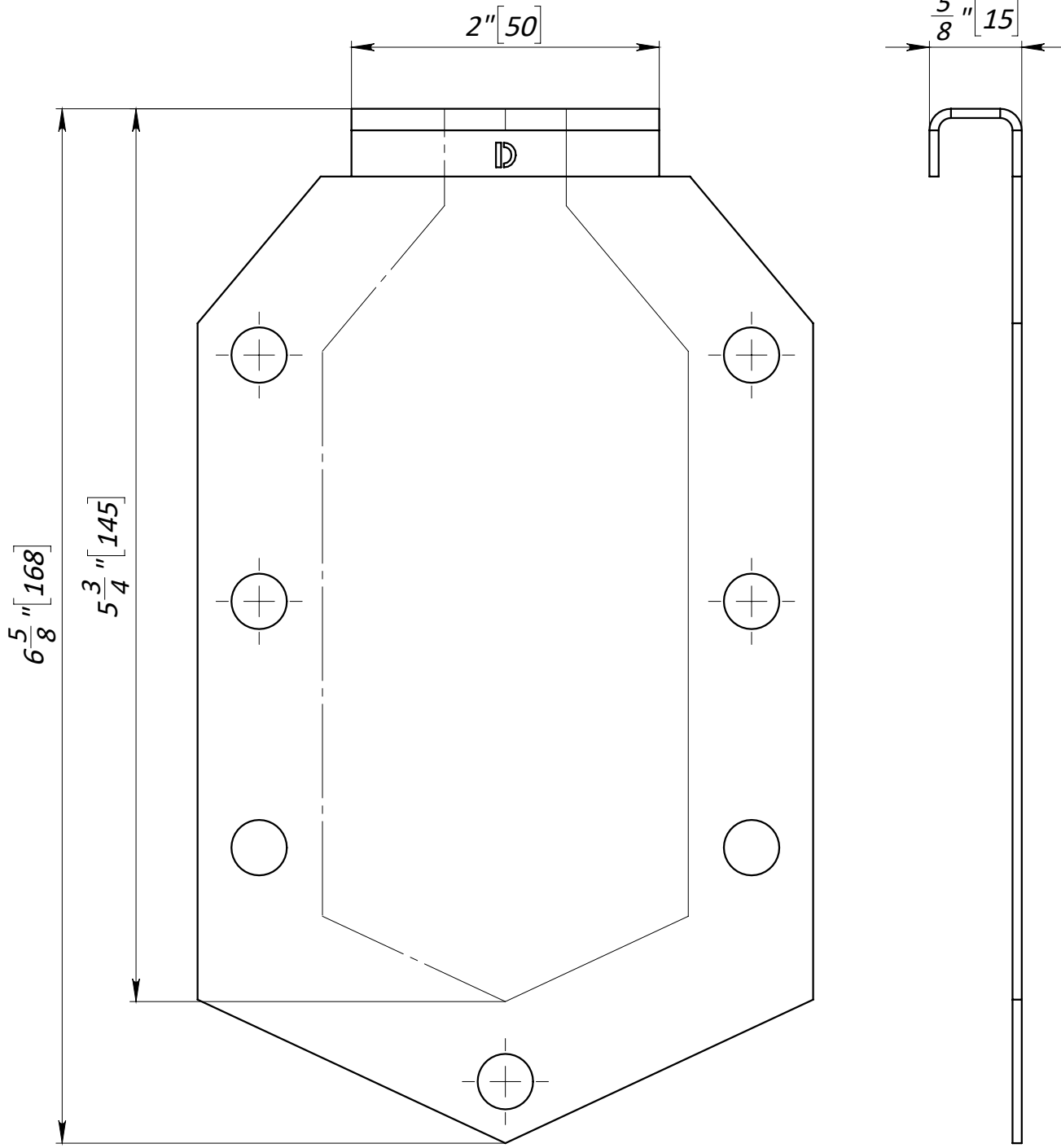
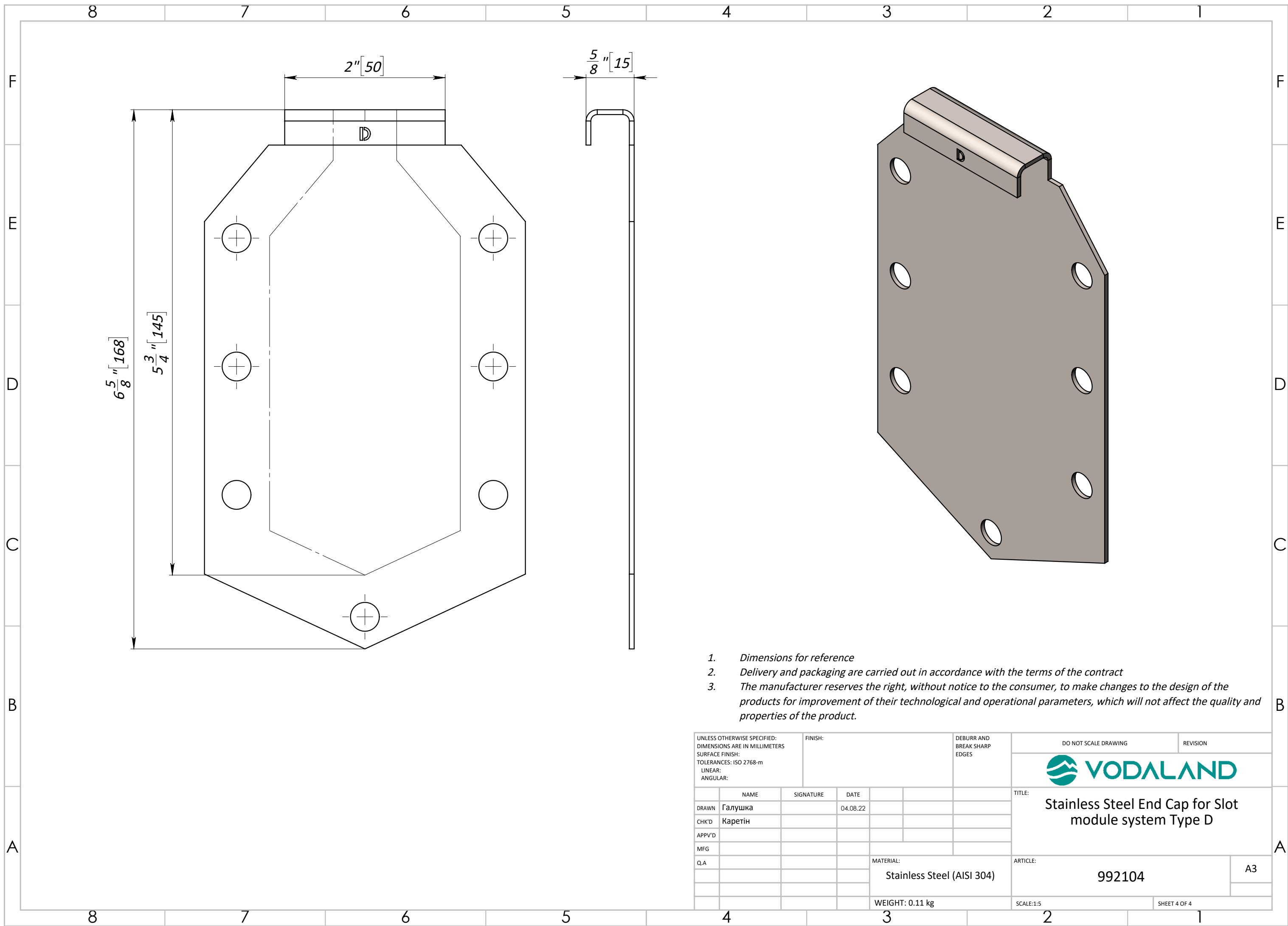

1. Dimensions for reference
2. Delivery and packaging are carried out in accordance with the terms of the contract
3. The manufacturer reserves the right, without notice to the consumer, to make changes to the design of the products for improvement of their technological and operational parameters, which will not affect the quality and properties of the product.

UNLESS OTHERWISE SPECIFIED: DIMENSIONS ARE IN MILLIMETERS SURFACE FINISH: TOLERANCES: ISO 2768-m LINEAR: ANGULAR:			FINISH:		DEBURR AND BREAK SHARP EDGES		DO NOT SCALE DRAWING		REVISION		
DRAWN			NAME		SIGNATURE		DATE		TITLE:		
CHK'D			Галушка				04.08.22		Stainless Steel End Cap for Slot module system Type D		
APPV'D			Каретін						ARTICLE:		
MFG									992104		
Q.A									A3		
							MATERIAL:		SCALE:1:5		
							Stainless Steel (AISI 304)		SHEET 4 OF 4		
							WEIGHT: 0.11 kg				