



ARMAX

SS986HP

SAFARI ARMAX SNORKEL

Suits: Ford Ranger Raptor PX MkIII MY19 onwards
2.0L Bi-Turbo Diesel (YN2S Engine)



01/05/2021

Parts List

ITEM	PART NO.	DESCRIPTION	QTY
1	681-133-600	BODY - SNORKEL (SS986HP)	1
2	000-135-960	4" AIR RAM ASSEMBLY	1
3	681-032-600	BRACKET - UPPER MOUNTING	1
4	000-002-100	BOLT - HEX - 6mm x 1.0 x 14mm (SEMS)	2
5	681-435-600	GASKET - UPPER MOUNTING BRACKET (Black Nylon)	1
6	000-958-625	POP RIVET - 4.8mm x 10mm (Black Anodised)	3
7	000-110	STUD - 8mm x 1.25 x 25mm - S/S	6
8	000-311-300	WASHER - BODY - 8mm x 30mm - S/S	6
9	000-205-300	NUT - NYLOC - 8mm x 1.25mm - S/S	6
10	681-024-600	HOSE - AIR ENTRY (Flanged)	1
11	680-025-700	PLATE - HOSE SUPPORT - (Main) - S/S	1
12	680-025-725	PLATE - HOSE SUPPORT - (Front) - S/S	1
13	000-093-400	BOLT - B/H 4.0mm x 0.7 x 16mm - S/S	4
14	000-094-300	BOLT - B/H 4.0mm x 0.7 x 20mm - S/S	2
15	000-095-300	BOLT - B/H 4.0mm x 0.7 x 25mm - S/S	5

16	000-300-350	WASHER - BODY - 4.0mm x 12mm - S/S	11
17	000-223-300	NUT - NYLOC - 4.0mm x 0.7mm - S/S	11
18	000-1911	CLAMP - HOSE - 100/120mm - S/S	1
19	680-959-000	PLUG - AIR INLET BLANK-OFF	1
20	000-951	SCREW - S/T - 4.2mm x 13mm - S/S	2
21	681-967-600	PLATE - INNER GUARD SUPPORT - S/S (Pressed)	1
22	000-1020-300	BOLT - B/H CAP SCREW 5.0mm x 0.8 x 12mm - S/S	10
23	000-320-350	WASHER - BODY 5.0mm x 15mm - S/S	10
24	000-221-300	NUT - NYLOC 5.0mm x 0.8mm - S/S	10
25	000-038-300	BOLT - B/H CAP SCREW 6.0mm x 1.0 x 12mm - S/S	1
26	000-353	WASHER - BODY 6.0mm x 18mm - S/S	1
27	000-204	NUT - NYLOC 6.0mm x 1.0mm - S/S	1
28	000-1931/B	CLAMP - HOSE - SIZE 64 (BLACK)	1
29	680-217-700	TEMPLATE - AIR CLEANER HOUSING (Upper Side)	1
30	680-217-725	TEMPLATE - AIR CLEANER HOUSING (Lower Side)	1
31	680-217-750	TEMPLATE - AIR CLEANER HOUSING (Upper Front)	1
32	680-217-775	TEMPLATE - AIR CLEANER HOUSING (Front Lower)	1
33	681-017-600	TEMPLATE - GUARD PANEL	1



ARMAX

SS986HP

SAFARI ARMAX SNORKEL

Suits: Ford Ranger Raptor PX MkIII MY19 onwards
2.0L Bi-Turbo Diesel (YN2S Engine)

Installation Guide

Fitment to:

- Right Hand Side

Fitting Time:

- 240min

Special Tools:

- Body Saw (Reciprocating)
- Step Drill
- 90 degree Drill
- 4.5, 5.0, 5.5 & 6.5mm Drill bits
- Files / Sandpaper
- Allen Key Set (Metric)
- Masking Tape
- Loctite 243 (thread lock)
- Touch-up paint
- Sikaflex 227 Adhesive Sealant

Prior to commencing the installation, it is the installer's responsibility to verify that all components and particularly the template (Item 33) are correct.

1

Remove and discard the Air intake duct.

Refit the two bolts removed after discarding the air intake duct.

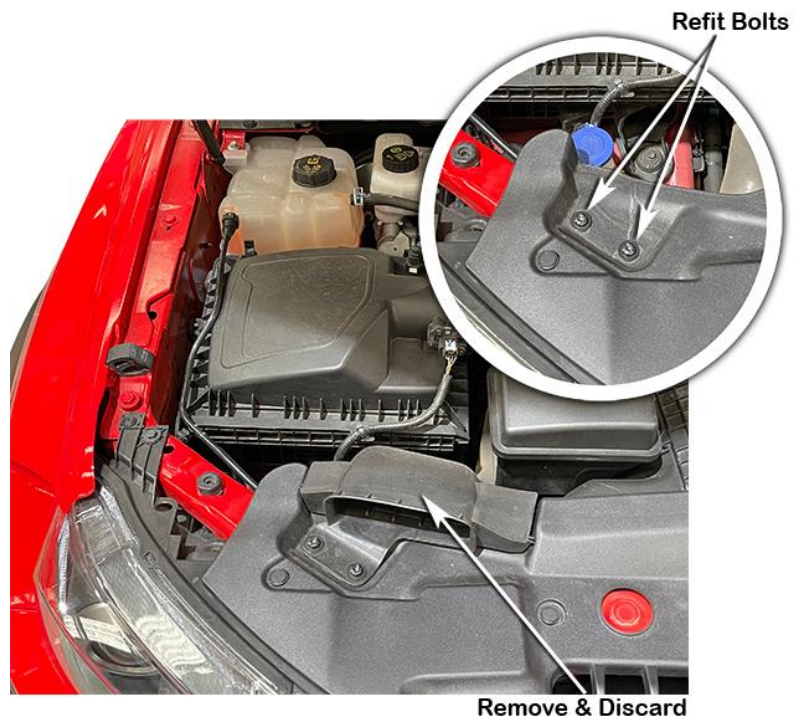

2

Remove the following in accordance with the factory service manual:

- Air Cleaner Assembly

3

Remove and discard the inner guard plug (if fitted).

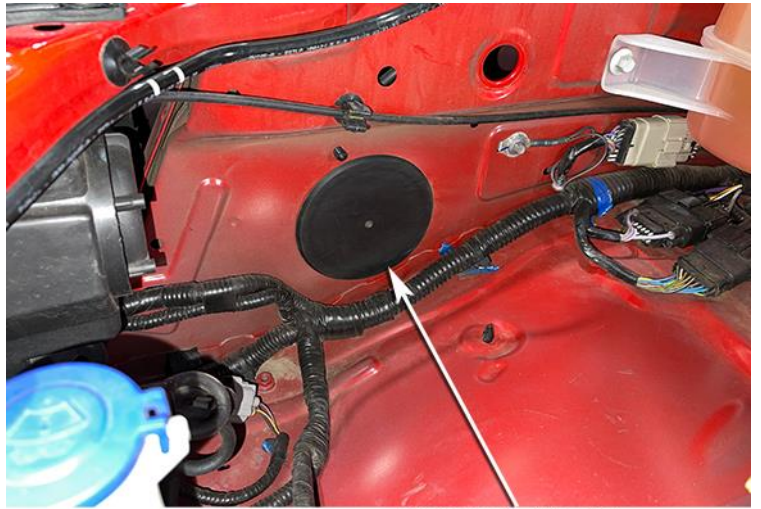

Remove & Discard

4

Remove and discard the four perforated sections from the guard panel template (item 33) as shown.

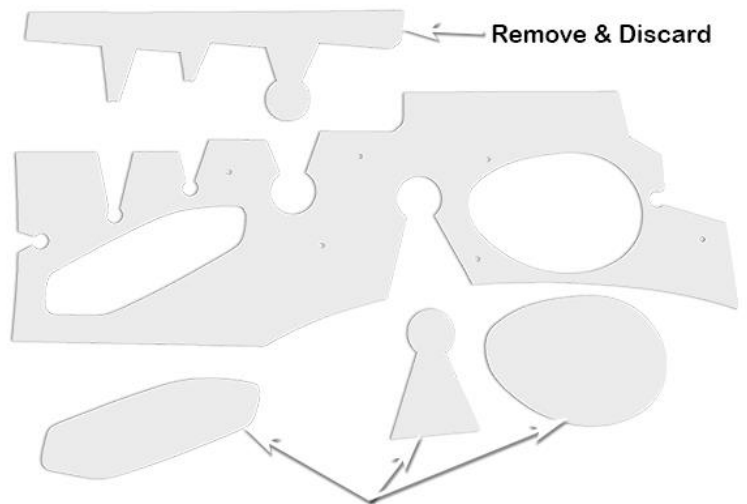

Remove & Discard

5

Align the guard panel template (Item 33) with the upper and rear edges of the RHS guard panel as shown.

Tape the template to the guard panel with masking tape.

Mark all hole positions and the cut-out section with a felt tip pen.

Remove the template.

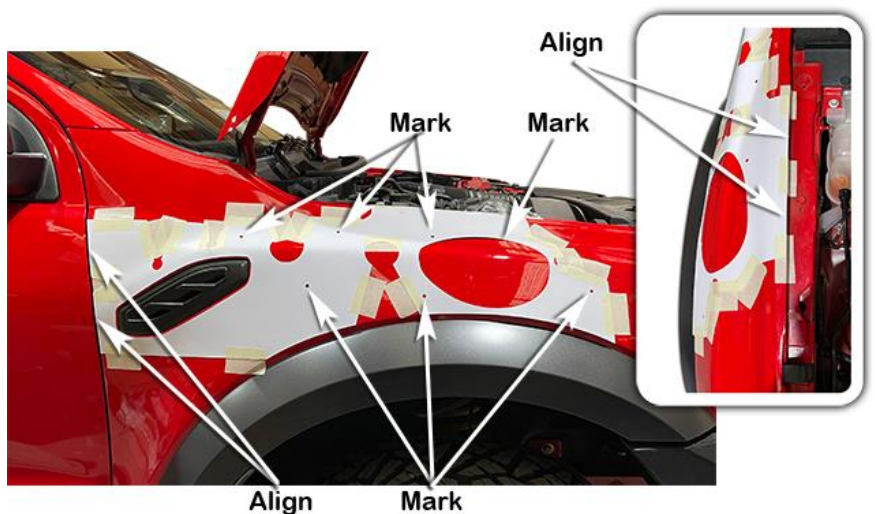

Drill a pilot hole for each of the marked hole positions.

Use a step drill to drill the six mounting holes to 16mm diameter.

Drill 1 or 2, 10mm diameter holes in the cut-out section for a start/stop point for the body saw, using the body saw cut the main hole in the guard panel as marked from the template cut-out in step 5.

Using a file or sandpaper, smooth off the edges of the cut-out section and the six mounting holes.

Prime and paint the main hole and the 16mm diameter holes to seal the unpainted edges of the guard panel.

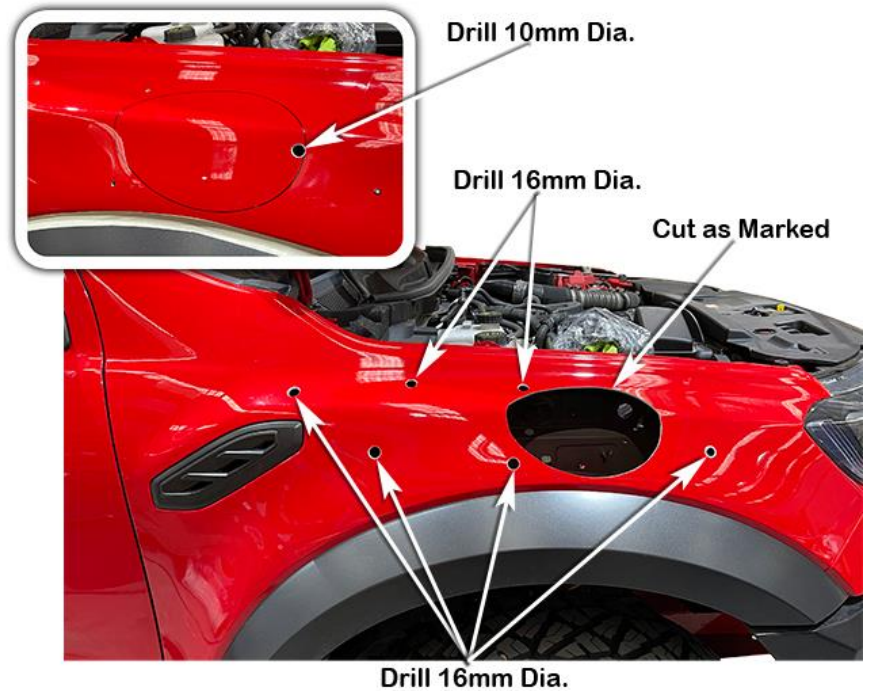

Remove the following in accordance with the factory service manual:

- R/H Mudflap
- R/H Fender Flare
- R/H Inner Guard Liner

Hint: The Fender Flare needs to be removed first to enable the removal of the Inner Guard Liner, using a 8mm ¼" drive socket reach through the main hole in the fender to release the Fender Flare clips.



Fender Flare & Inner Guard Liner Removed

8

Install the upper mounting bracket (Item 3) to the snorkel body (Item 1) with hex bolts (Item 4).

Apply Loctite 243 to each of the stainless steel mounting studs (Item 7) and install the studs finger tight into the snorkel body (Item 1) mounting inserts as shown.

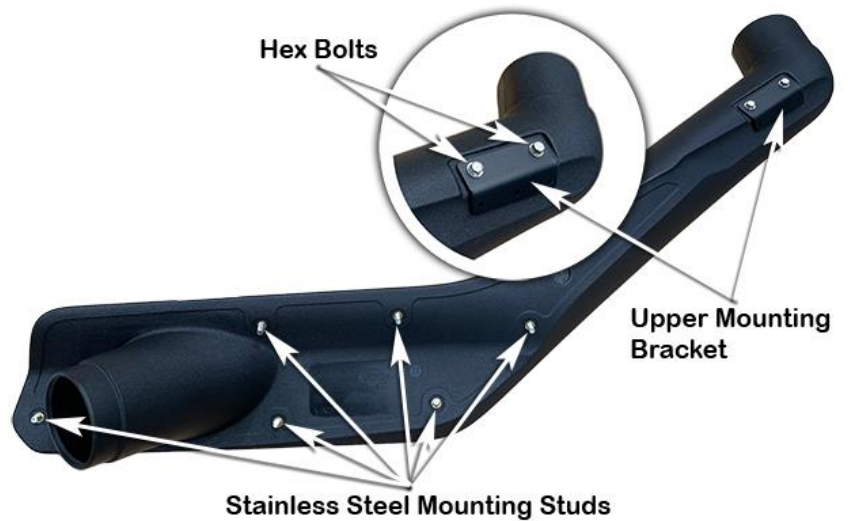

9

Place a strip of masking tape along the A-pillar panel.

Carefully install the snorkel body (Item 1) onto the guard panel.

With the snorkel body correctly positioned, mark the outline of the upper mounting bracket (Item 3) onto the masking tape.

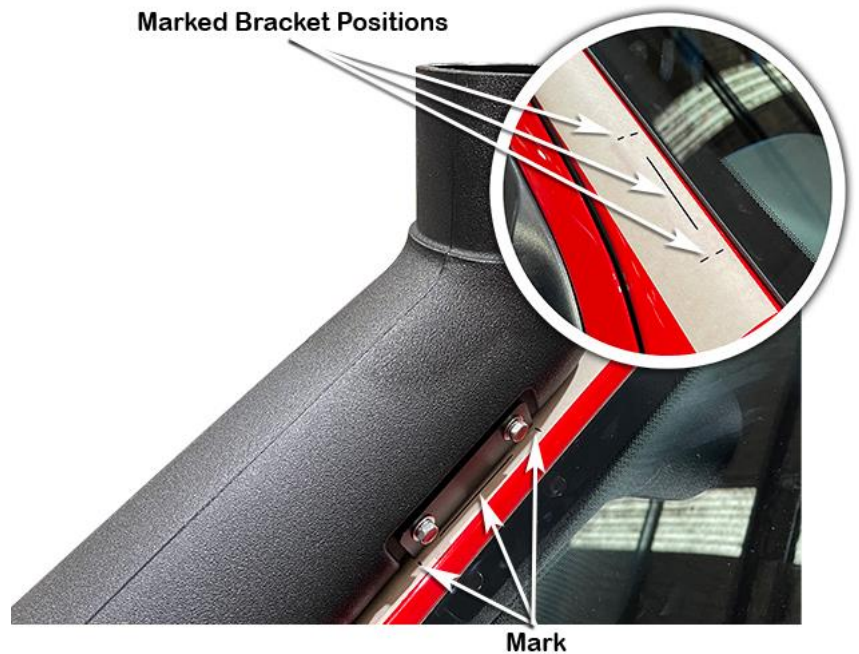

10

Remove the snorkel body (Item 1) from the vehicle and remove the upper mounting bracket (Item 3) from the snorkel body.

Position the upper mounting bracket (Item 3) onto the A-pillar and align the bracket with the marked bracket outline. Mark the three mounting hole positions with a felt tip pen.

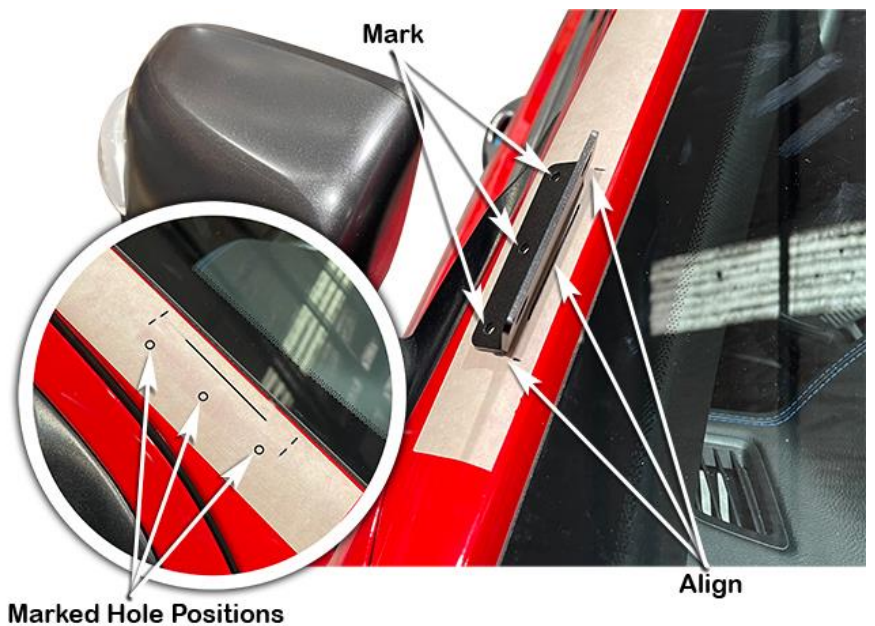

Drill a pilot hole at each of the three marked hole positions. Drill each hole position to 5mm diameter with a 5.0mm drill bit.

Deburr and paint holes to prevent rust.



Drill 5mm Dia.

Install the upper mounting bracket gasket (item 5) and the upper mounting bracket (item 3) onto the A-pillar, install the three pop rivets (item 6) through the holes in the upper mounting bracket and bracket gasket and into the three 5.0mm holes in the A-pillar.

Using a pop rivet gun, secure the upper mounting bracket (Item 3) and bracket gasket (item 5) to the A-pillar panel.

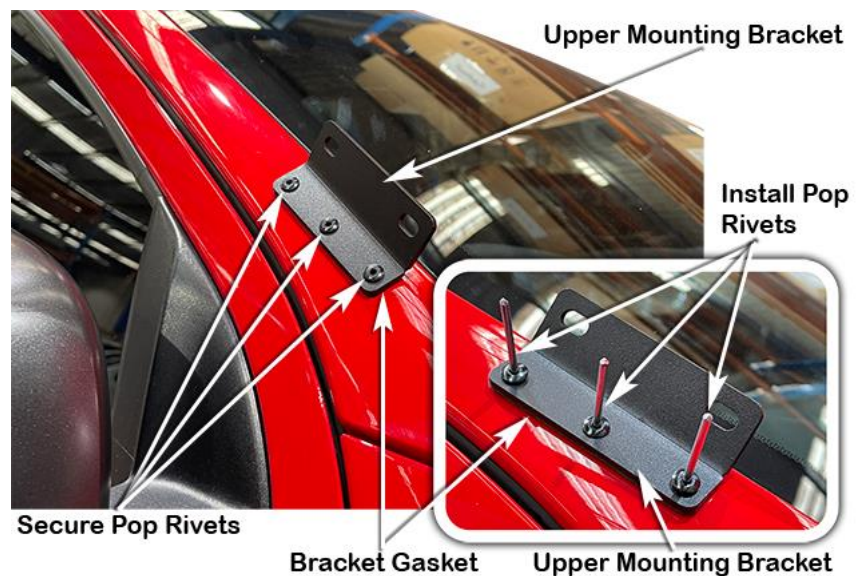

Mark the centres of the two spot welds holding the bracket (shown) to the inner guard panel, using a 6.5mm drill bit and a 90 degree drill, drill out the two spot welds.

Using a small screwdriver or pry bar remove the bracket.

Unclip the washer hose from the inner guard panel.

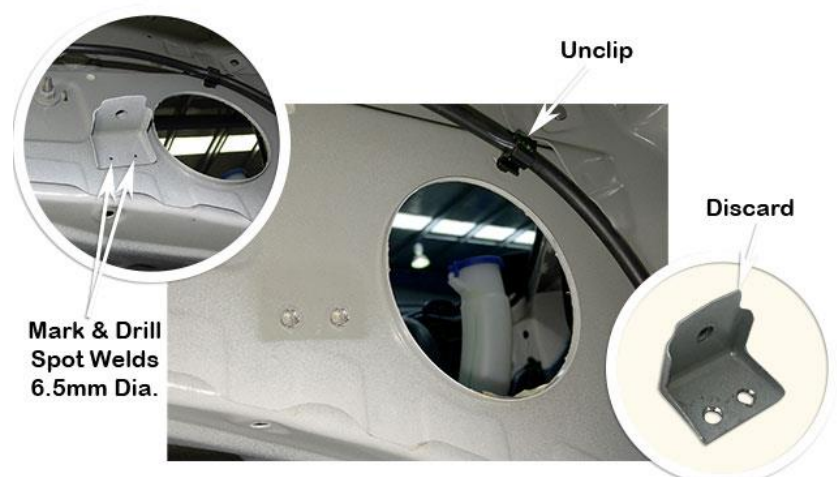

Unclip the wiring loom and bonnet pull cable from the mounting positions, move and tape to avoid damaging.

Install the inner guard support plate (item 21) to the inner guard panel, align and fasten to the 6.0mm hole in the inner guard panel with a M6 x 12mm button head bolt (item 25), M6 body washer (item 26) and M6 nyloc nut (item 27), align the support plate to the fold in the inner guard panel and drill one of the front holes with 5.5mm drill bit, secure the plate with a M5 button head bolt (item 22), body washer (item 23) and nyloc nut (item 24), mark or drill the remaining nine mounting hole positions with a 5.5mm drill bit, mark or drill the washer hose relocation hole with a 6.5mm drill bit.

Mark the inner guard panel cut-out with a felt tip pen.

Remove the inner guard support plate (item 21).

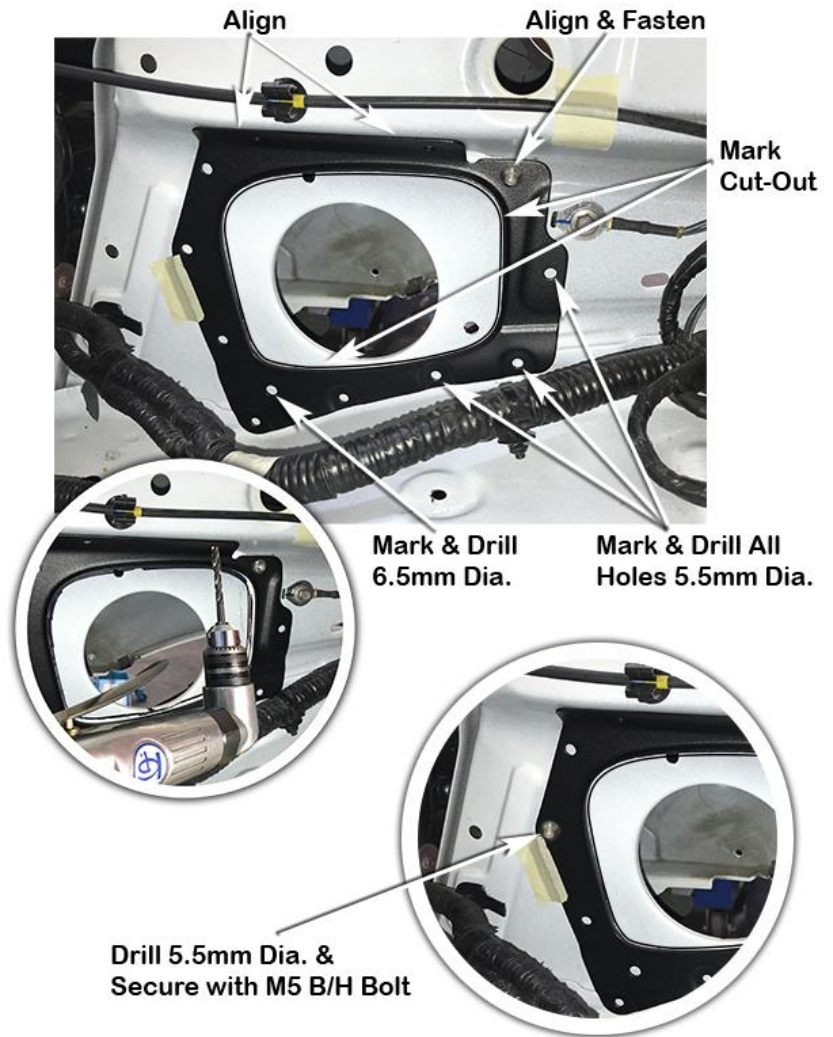

Using the body saw, cut the marked cut-out in the inner guard panel, cutting on the outside of the marked line.

Deburr and paint all holes and cut section of panel to prevent rust.



Apply Sikaflex adhesive sealant to the inner guard support plate (item 21) and install the support plate to the inner guard panel, install all ten M5 x 12mm button head bolts (item 22), M5 body washers (item 23) and M5 nyloc nuts (item 24), install the M6 x 12mm button head bolt (item 25), M6 body washer (item 26) and M6 nyloc nut (item 27).

With all fasteners installed, secure the inner guard support plate to the inner guard panel.

Clean-up any excess adhesive sealant to ensure a neat finish.

Clip the wiring loom into the standard mounting holes.

Clip the bonnet pull cable into the standard mounting hole.

M6 x 12mm B/H Bolts w/ Body Washers & Nyloc Nuts

Inner Guard Support Plate



M5 x 12mm B/H Bolts w/ Body Washers & Nyloc Nuts (x10)

The ribs shown on the front corner of the air cleaner base must be neatly removed, using a body saw, side cutters, sharp knife or grinder remove the ribs.

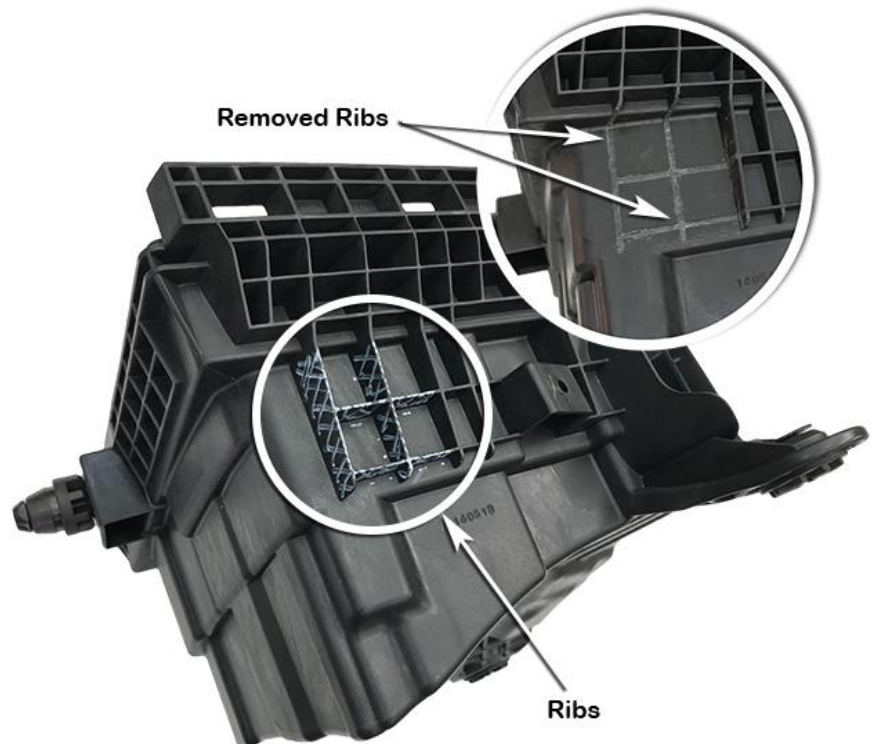

Neatly apply masking tape to the upper front surface of the air cleaner base, align the front upper template (item 30) to the air cleaner base as shown.

Mark the 2 hole positions and the cutting line.

Remove the template.

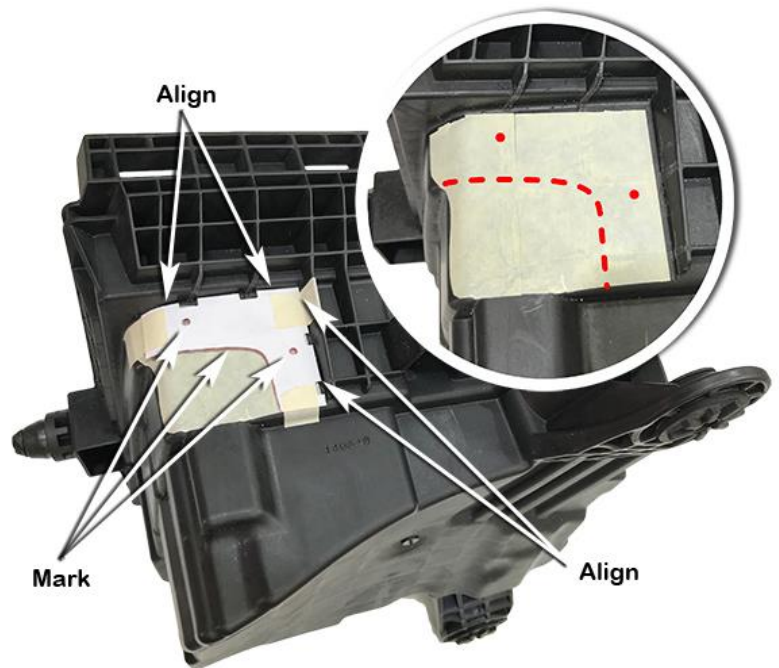

Neatly apply masking tape to the lower front surface of the air cleaner base, align the front lower template (item 31) to the air cleaner base as shown.

Mark the 2 hole positions and the cutting line.

Remove the template.

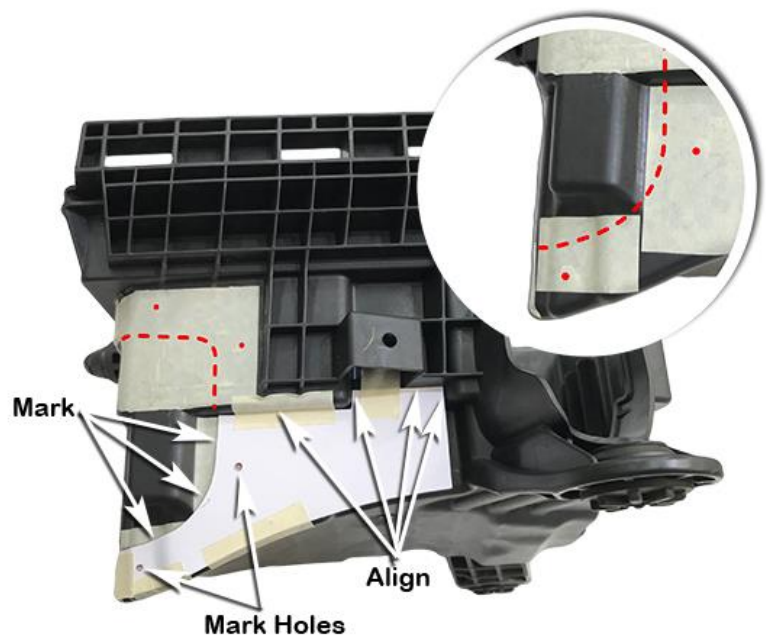

Neatly apply masking tape to the upper side surface of the air cleaner base, align the upper side template (item 28) to the air cleaner base as shown.
 Mark the 2 hole positions and the cutting line.

Remove the template.

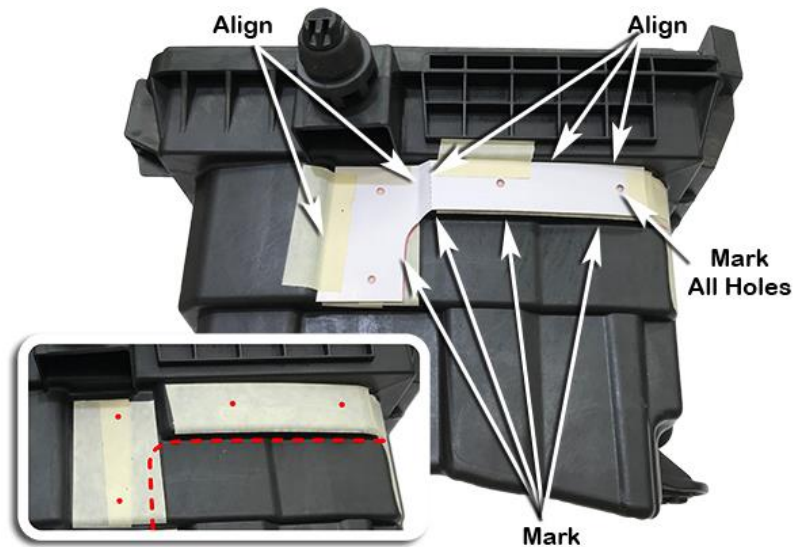

Neatly apply masking tape to the lower side surface of the air cleaner base, align the lower side template (item 29) to the air cleaner base as shown.
 Mark the 2 hole positions and the cutting line.

Remove the template.

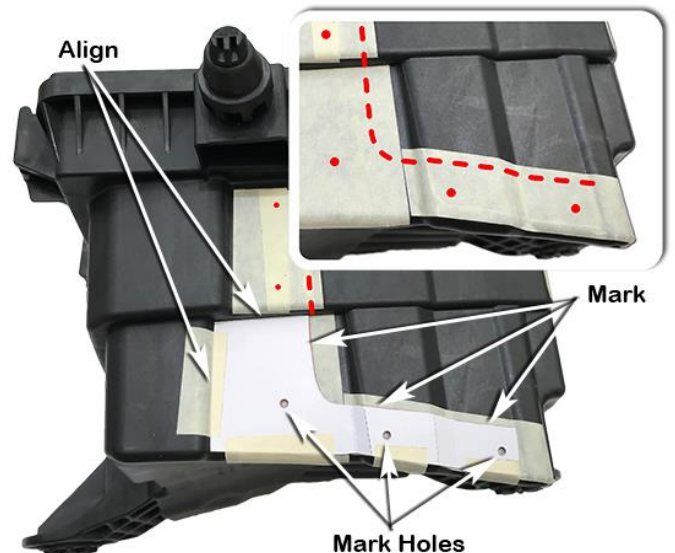

Drill a pilot hole at each of the marked hole positions, using a 4.5mm diameter drill bit, drill the eleven holes to 4.5mm as shown.

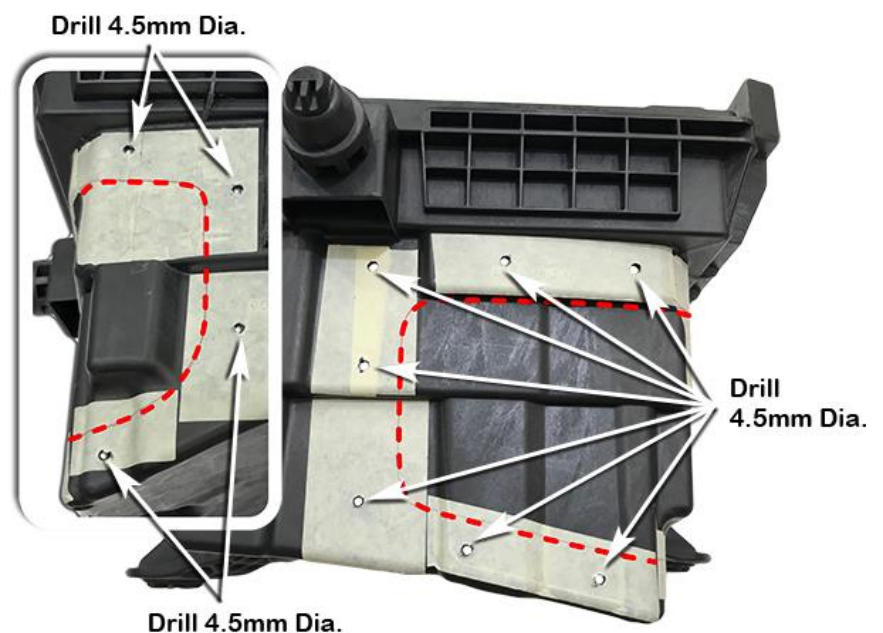

Using the body saw cut the new air inlet hole as marked from the templates in steps 18, 19, 20, & 21.

Use a file or die grinder to clean-up the cut section.

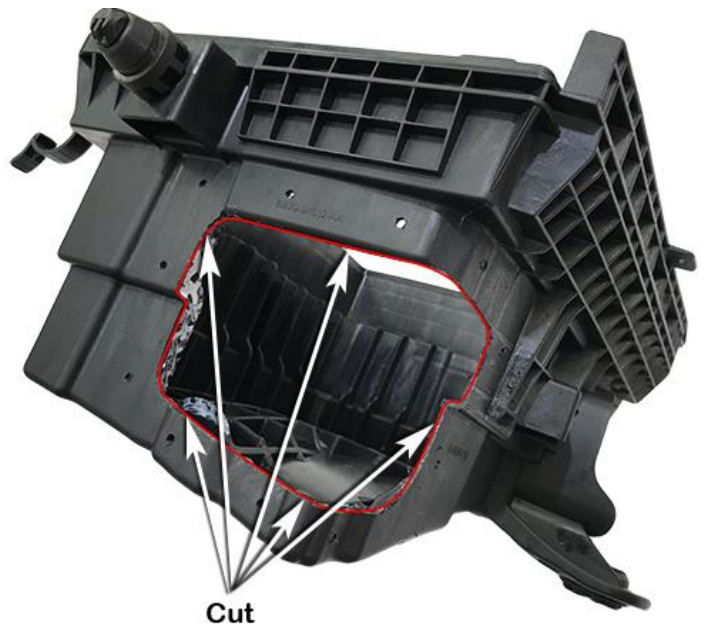

Using the body saw neatly remove the internal rib shown.

Using a die grinder, grind away the corner ribbing and the raised ribbing in the centre of the air cleaner base as shown.

Clean-up and deburr all cuts.

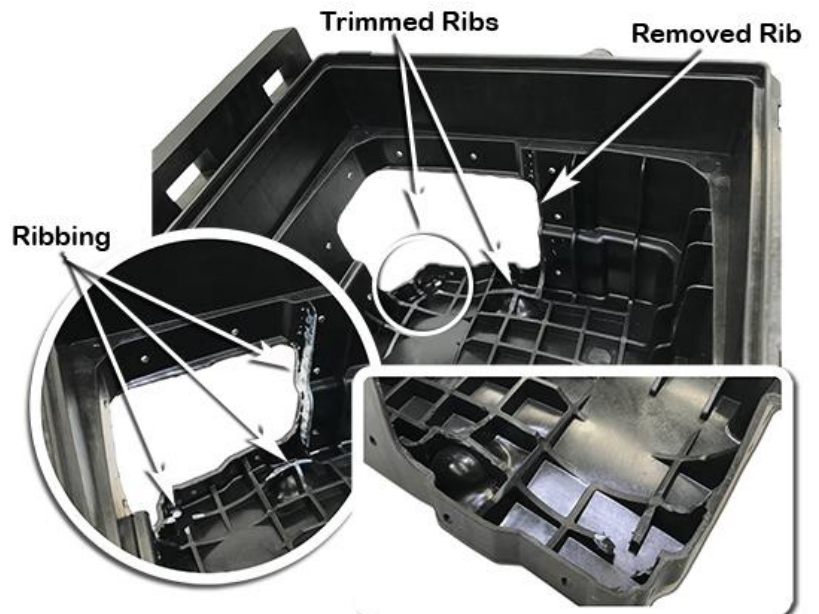

Apply Sikaflex adhesive sealant to the mating surfaces of the air cleaner base and air entry hose flange.

Install the air entry hose (item 10) onto the air cleaner base, install the main and front hose support plates (item's 11 & 12) to the hose, start installing the M4 button head bolts (item's 13, 14 & 15) through the support plates, air entry hose and air cleaner base.

Note: There are three different length bolts supplied in the kit, ensure the correct length bolts are install into correct positions as shown.

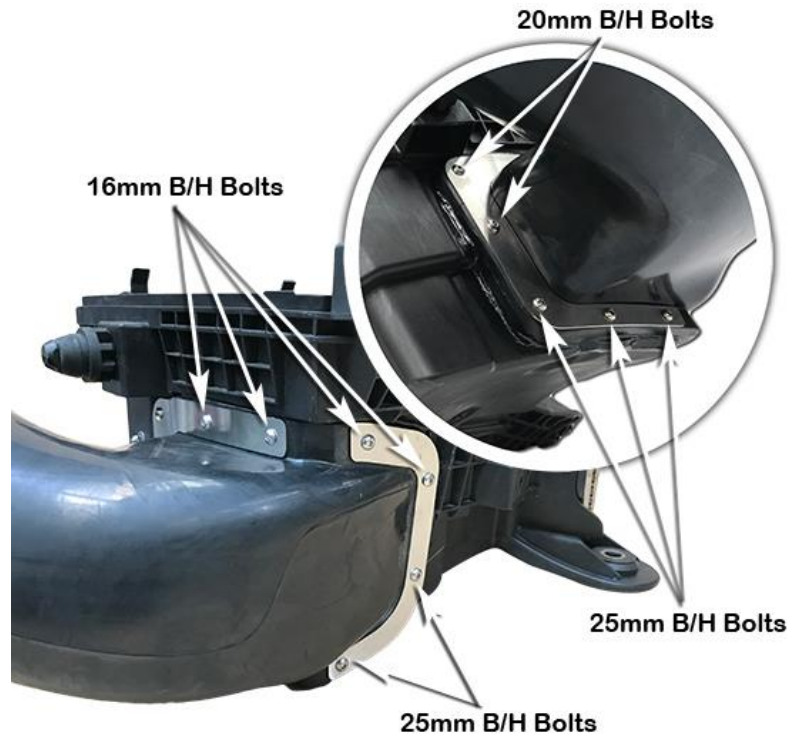

Install a M4 body washer (item 16) and a M4 nyloc nut (item 17) to each of the bolts, tighten all the nuts, securing the air entry hose to the air cleaner base.

Clean-up any excess sealant to ensure a neat finish.



Measure and mark two hole positions 5.0mm in from the end of the air cleaner inlet snout as shown.

Drilled the two marked hole positions with a 4.0mm drill bit.



Apply Sikaflex adhesive sealant to the air cleaner inlet and blank-off plug (item 19), install the blank-off plug into the air cleaner inlet hole and secure with two self-taping screws (item 20).

Clean-up any excess sealant to ensure a neat finish.

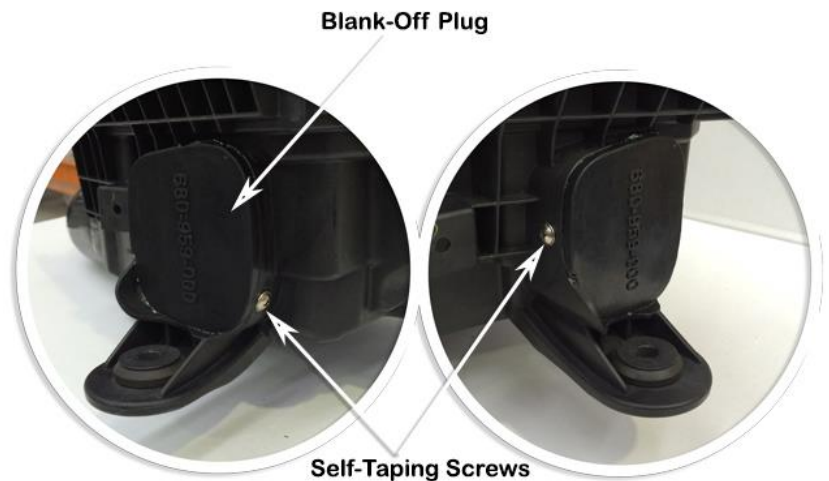

INSTALLER OPTION :

The air cleaner base contains a drain hole as shown. The drain hole can permit water to enter the air intake.

Safari advises that the drain hole should be sealed to ensure a watertight installation.

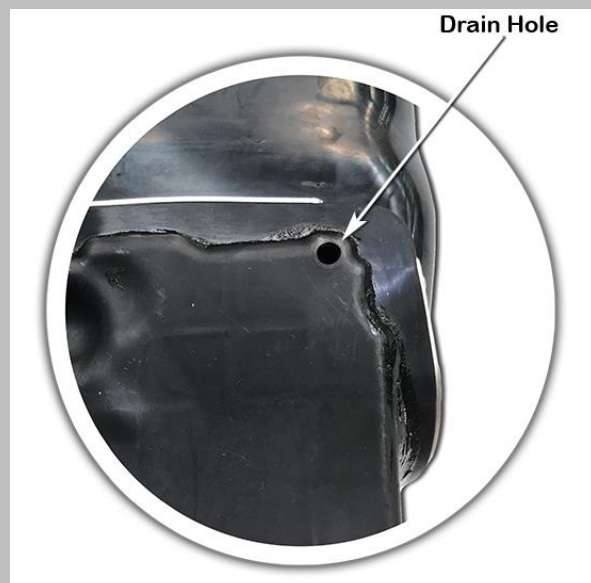

The end of the air entry hose (item 10) must be squashed inwards and taped to hold as shown.

N.B: it is critical the hose is taped the way shown in the photo, for installation purposes.

With the hose taped, spray lubricant over the outside of the hose.

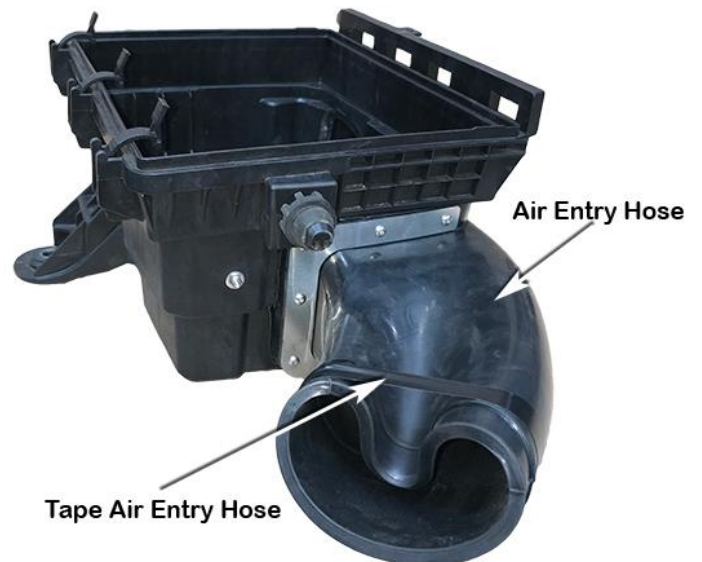

Install the air cleaner base into position, guiding the air entry hose through the hole in the inner guard panel, with the air cleaner base correctly positioned, installed the two standard mounting bolts and fasten.

Remove the tape.

Loosely install the 100/120mm hose clamp (Item 18) onto the air entry hose (item 10).



Carefully install the snorkel body (Item 1) to the guard panel, guiding the snorkel body outlet into the air entry hose (item 10), align the snorkel body to guard panel and upper mounting bracket.

When correctly aligned, fasten the snorkel body to the guard panel with body washers (Item 8) and nyloc nuts (Item 9).

Fasten the snorkel body to the upper mounting bracket with hex bolts (Item 4).

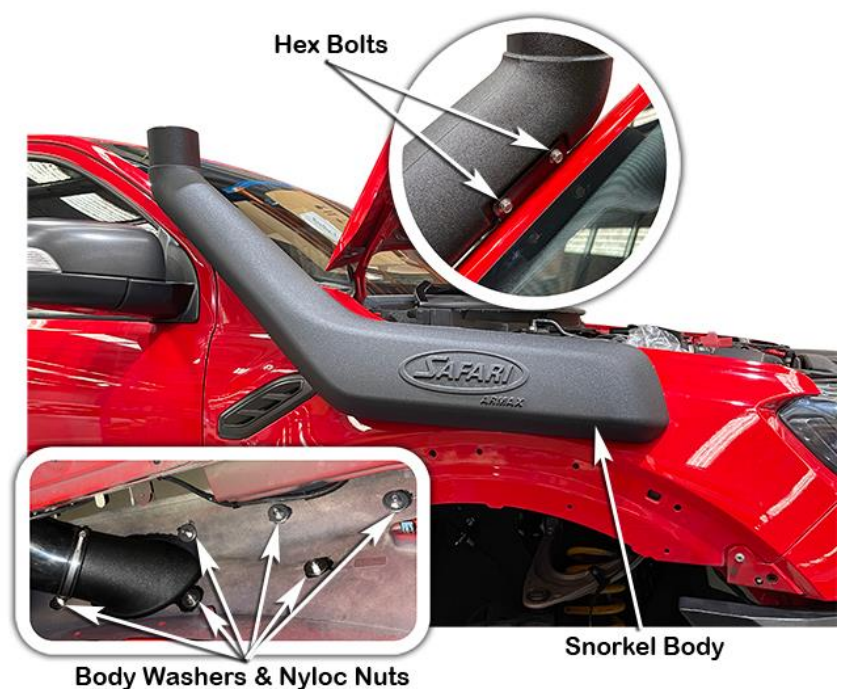

33

Ensure the air entry hose is correctly installed onto the snorkel body outlet and tighten the 100/120mm hose clamp (item 18).



34

Relocate the washer hose mounting clip into the 6.5mm hole drilled in the inner guard panel in step 14.



35

Loosely install the black hose clamp (Item 28) over the base of the air ram assembly (Item 2).

Install the air ram assembly onto the snorkel body.

Align the air ram assembly and tighten the black hose clamp (Item 28).



36

Install the RH guard liner, fender flare, mud flap, air cleaner element, air cleaner lid, reconnect sensor wiring and any other items that may have been removed during the snorkel installation process.

37

N.B: It is the installer's responsibility to ensure that all connections are watertight.