

oeuf®

FAWN BASSINET + CRIB / COT

ITEM #

USA • CANADA • KOREA

AUSTRALIA • NEW ZEALAND

1FBC0x

1FBC0x-A

ek72071

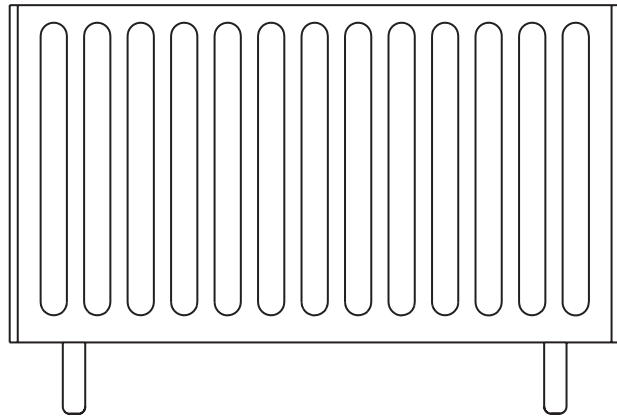
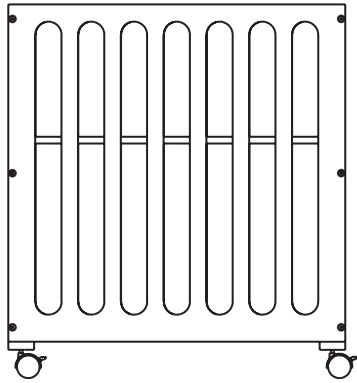

Oeuf LLC 234 Underhill Ave | Brooklyn, NY 11238 | USA +1 (718) 965-1216 | www.oeufnyc.com

Distributed internationally by:

Canada

Monte Distribution Inc.
270 Belfield Rd
Toronto, Ontario
M9W 1H5
Canada
Tel: +1 866 604 6755
info@oeufcanada.com

UK

Kids At Home Distrb.
Newick Business Centre
Church Road
Newick, BN8 4NA
England
Tel: +01825 724160
kahdistribution@gmail.com

EU

Suede Import
20 Bis Rue des Champs
92600 Asnières-sur-Sein
France
Tel: +33 (0)1 40 86 06 03
suedeimport@yahoo.fr

Korea

J2 International Inc.
(주) 제이투인터내셔널
서울시 강남구 도산대로 506
재정빌딩 304호
Tel: +82 70 8247 7576
oeufkorea.igt@gmail.com

China

Arketype Limited
7F Metro Loft, 38 Kwai Hei St.
Kwai Chung, N.T.,
Hong Kong
+852 2110 9400
www.arketype.com

Australia

Kido Agencies
Postal: PO Box 6039
Alexandria NSW 2015
Australia
Tel: +61 2 9045 7799
info@kidoagencies.com

Made in Latvia

All Parts & Fittings

Parts list - Complete

Liste des Presentation

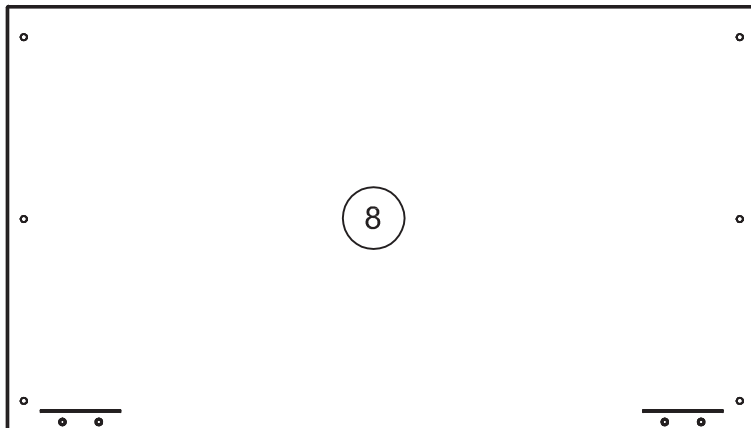
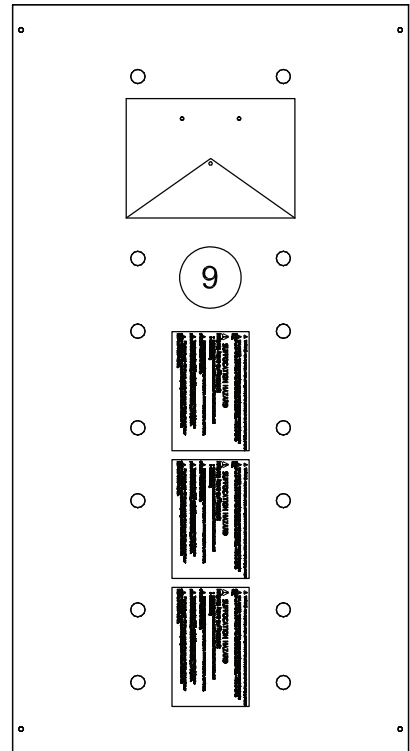
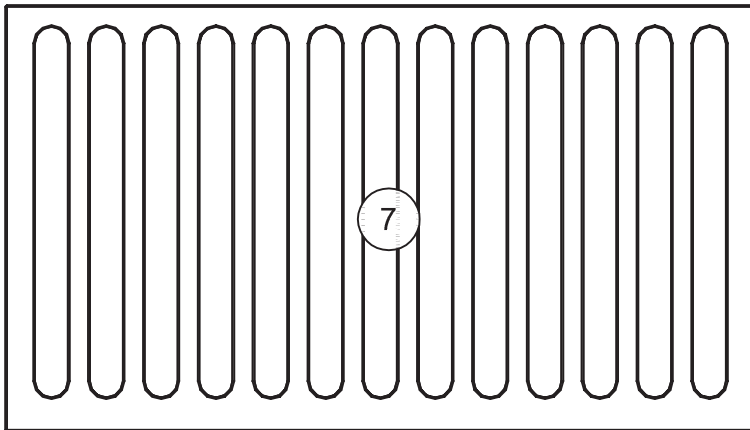
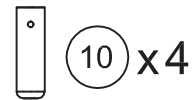
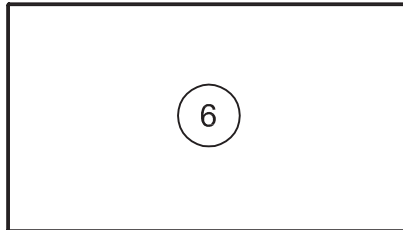
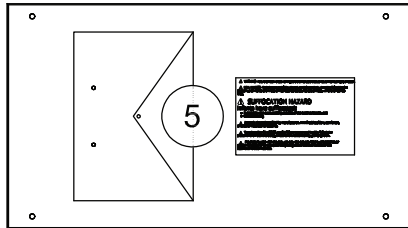
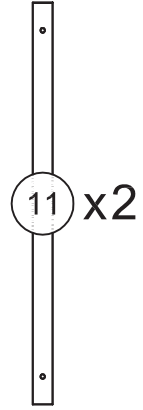
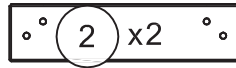
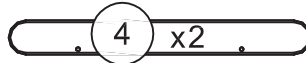
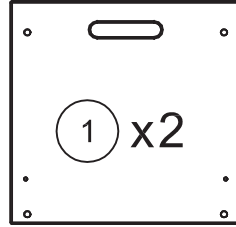
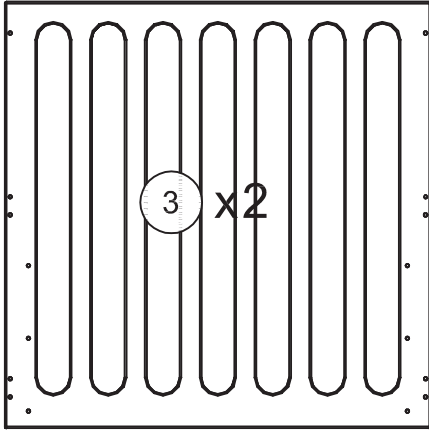

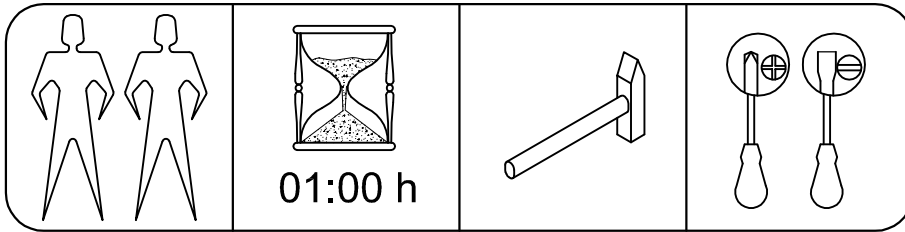

01:00 h

Fittings List - Complete

Liste des Pièces

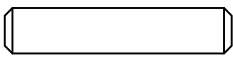
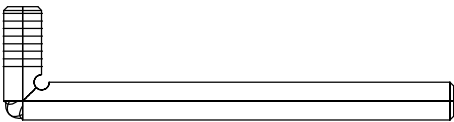
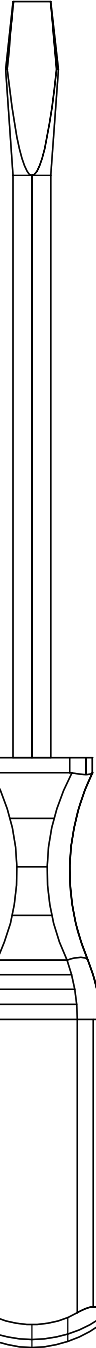
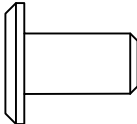
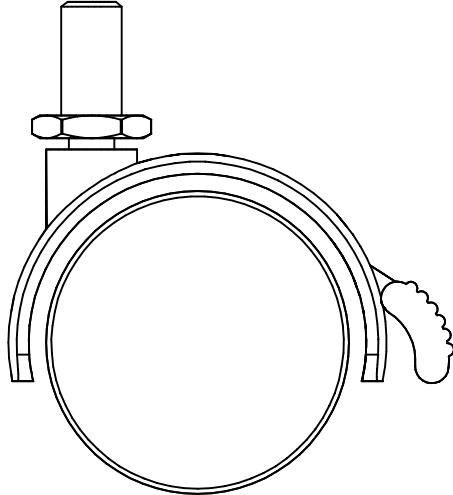
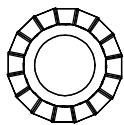
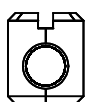
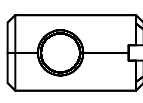
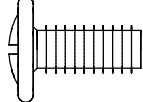
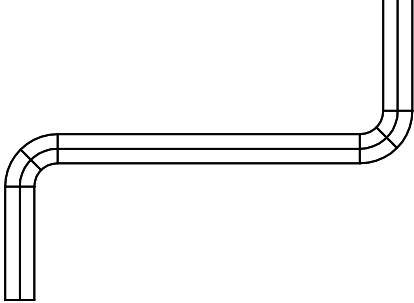
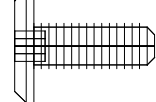
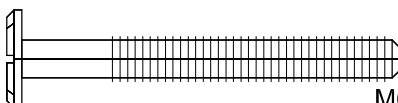
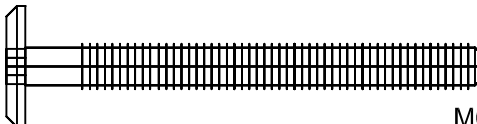
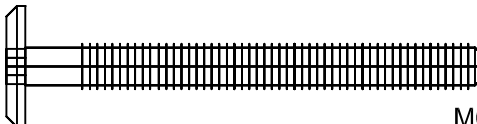
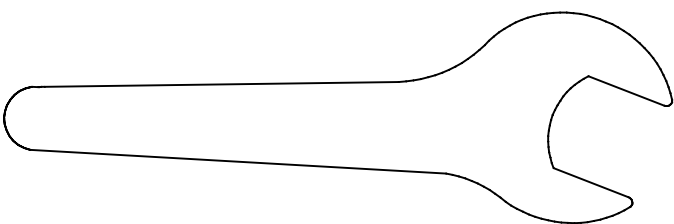
A		8 pcs Ø6x30	H		4 pcs	<div data-bbox="1286 512 1495 595" style="border: 1px solid black; padding: 2px;">P</div>  <div data-bbox="1286 1984 1495 2121" style="border: 1px solid black; padding: 2px; text-align: center;">1 pc</div>						
B		4 pcs	<div data-bbox="632 651 1264 1200" style="border: 1px solid black; padding: 10px;">  </div>									
C		12 pcs										
D		16 pcs Ø10x13										
E		4 pcs Ø10x18										
F		8 pcs Ø7x14	<div data-bbox="632 1211 1264 1570" style="border: 1px solid black; padding: 10px;">  </div>									
G		8 pcs M6x16										
L		16 pcs M6x50	<div data-bbox="632 1720 1264 1865" style="border: 1px solid black; padding: 10px;">  </div>									
M		4 pcs M6x60										
N		1 pc										

Bassinet Assembly

US / Australia Warnings

 **WARNING**—Failure to follow these warnings and the instructions could result in serious injury or death.

 **FALL HAZARD**—To help prevent falls, do not use this product when the infant begins to push up on hands and knees or has reached 18 pounds (8.2 kilos), whichever comes first.

SUFFOCATION HAZARD

Infants have suffocated:

- In gaps between extra padding and side of the bassinet/cribble, and
- On soft bedding

 Use only the pad provided by manufacturer. NEVER add a pillow, comforter, or another mattress for padding.

 To reduce the risk of SIDS, pediatricians recommend healthy infants be placed on their backs to sleep, unless otherwise advised by your physician.

 If a sheet is used with the pad, use only the one provided by the bassinet or cradle manufacturer or one specifically designed to fit the dimension of the bassinet or cradle mattress.

 Strings can cause strangulation! Do not place items with a string around a child's neck, such as hood strings or pacifier cords. Do not suspend strings over a bassinet or cradle or attach strings to toys.

 NEVER use on elevated surfaces for any reason.

 NEVER use near stairs.

 NEVER move, lift or transport bassinet while child is in it.

 Check bassinet regularly before use to ensure all parts are securely fastened and there are no missing or damaged parts. Contact the manufacturer if replacement parts or additional instructions are needed.

WARNING

- Do not use this bassinets if you cannot exactly follow the accompanying instructions.
- Do not use this bassinets for a child who can roll over or who has reached the manufacturer's recommended weight limit.
- Do not place in or near this bassinets any cord, strap or similar item that could become wrapped around a child's neck.
- Do not place this bassinets near a window or a patio door where a child could reach the cord of a blind or curtain and be strangled.
- Check this bassinets regularly before using it and do not use it if any parts are loose or missing or if there are any signs of damage. Do not substitute parts. Contact the manufacturer if replacement parts or additional instructions are needed.
- Use a bassinets mattress that is no thicker than 3.8 cm and is of such a size that, when it is pushed firmly against any side of the bassinets, it does not leave a gap of more than 3 cm between the mattress and any part of the sides of the bassinets.
- Children can suffocate on soft bedding. Do not place pillows, comforters or soft mattresses in this bassinets.
- Caregivers must ensure that the crib, cradle or bassinets is safe by checking regularly, before placing the child in it, that every part is properly and securely in place.

MISE EN GARDE

- Ne pas utiliser le moïse à moins d'être en mesure de suivre précisément les instructions qui l'accompagnent.
- Ne pas utiliser le moïse si l'enfant est capable de se retourner ou a atteint le poids maximal recommandé par le fabricant.
- Ne pas mettre dans le moïse ou à proximité de celui-ci des cordes, courroies ou objets semblables qui risqueraient de s'enrouler autour du cou de l'enfant.
- Ne pas placer le moïse près d'une fenêtre ou d'une porte-fenêtre où l'enfant pourrait se saisir des cordes d'un store ou d'un rideau et s'étrangler.
- Vérifier régulièrement le moïse préalablement à son utilisation et ne pas l'utiliser en cas de détection d'une pièce desserrée, de pièce manquante ou de tout signe de dommages. Ne pas substituer une pièce à une autre. Communiquer avec le fabricant pour obtenir, au besoin, une pièce de rechange ou des instructions supplémentaires.
- Utiliser un matelas pour moïse dont l'épaisseur est d'au plus 3,8 cm et dont la superficie permet d'empêcher, lorsqu'il est poussé fermement contre un côté quelconque du moïse, qu'un espace de plus de 3 cm soit créé entre le matelas et une partie quelconque de tout côté.
- L'enfant peut s'étouffer en présence d'articles de literie mous. Ne pas mettre dans le moïse d'oreiller, d'édredon ou de matelas mou.
- Toute personne qui s'occupe de l'enfant doit régulièrement, avant de déposer l'enfant dans le lit d'enfant, le berceau ou le moïse, vérifier si leurs pièces sont correctement et solidement en place.

Care & Maintenance

- When cleaning your cot, use a non-toxic, non-abrasive cleaner. Mix a solution of water with a small amount of a mild detergent. Apply to bed surface with a damp cloth.
- When moving the cot without castors assembled, always lifts the unit. Do not push or drag it to avoid damaging the base.
- It is important that the humidity levels in the room be controlled from extremes of too much humidity or too little. The bed should not be placed directly next to air-conditioning, outlets, fire places, radiators, space heaters, humidifiers, or dehumidifiers.
- Exposure to extreme variations of temperature and humidity can damage wood products.
- Keep the bed out of direct sunlight. UV rays may fade colors and in some cases darken them. It can cause crazing or hair line cracks in the finish. White finishes will darken naturally over time and exposure to direct sunlight will hasten this natural process along with some wood darkening; this is not considered to be a quality defect.
- If you need to put your cot in storage for any period of time do not store it in a damp or hot environment. Allow air flow around the furniture and do not stack anything on it.

Check List

- Always check the bed is free from damage before use. Do not use product if any damage is present.
- Regularly check that all assembly fittings are always tightened properly and retighten as necessary.
- Do not over-tighten fittings.

Sales Service

When you receive your Oeuf product, if you need assistance, spare parts or if you have any comments with respect to any aspect of the goods, please contact by email your **local retailer or distributor**.

In USA, please contact **help@oeufnyc.com**. You can also visit our website at **www.oeufnyc.com** for latest product information.

Parts List - Fawn Bassinet Only

Liste des Presentation

Mandatory warning label
(only one of the sides has a label)
must appear at inside of bassinet
after assembly.

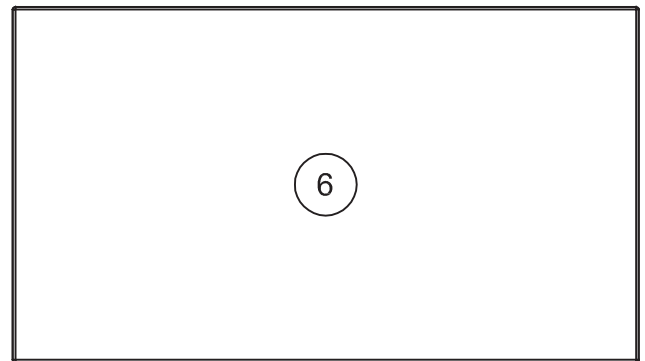
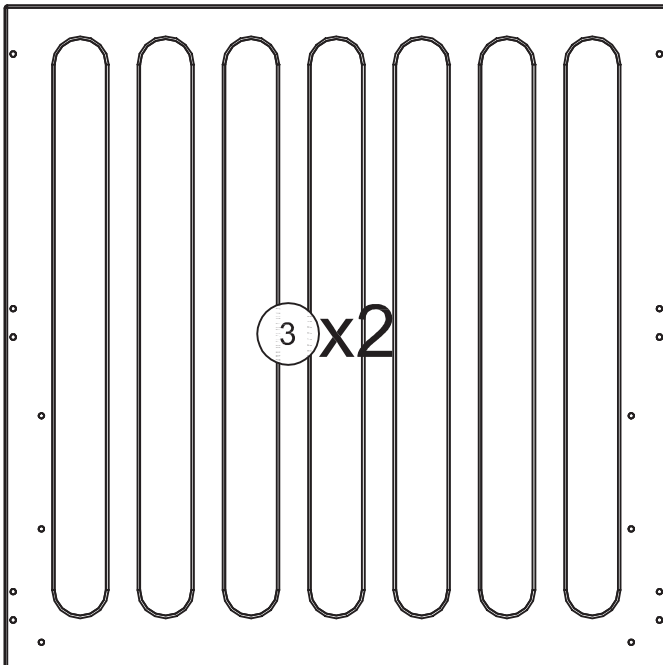
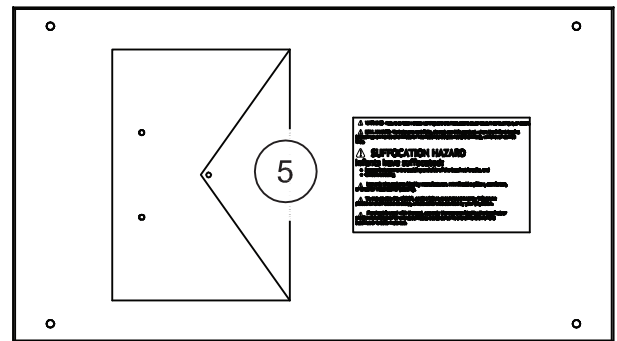
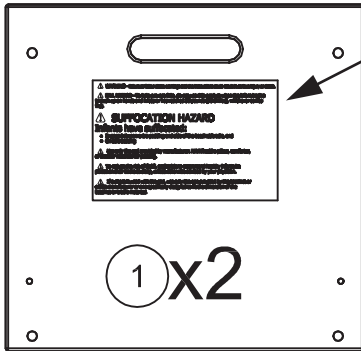

* Parts 3 are also used when
assembling bassinet.

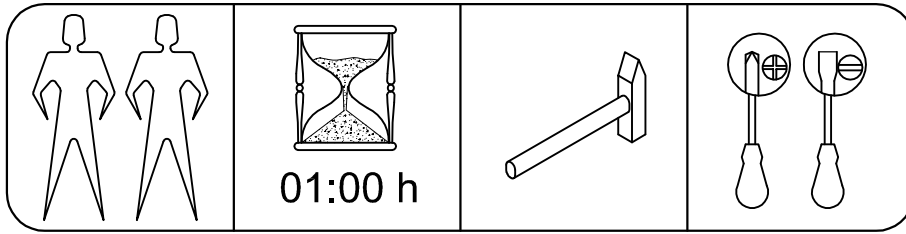

Parts List - Fawn Bassinet Only

Liste des Pièces

Please note:

Since some parts and fittings are used in both the bassinet and the crib, the two cannot be assembled at the same time.

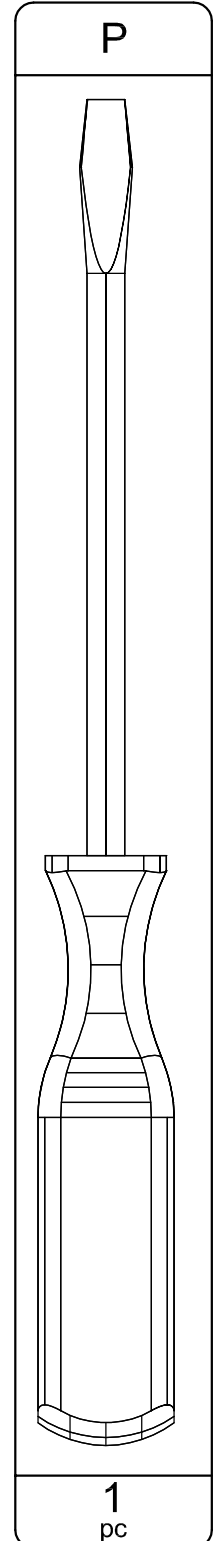
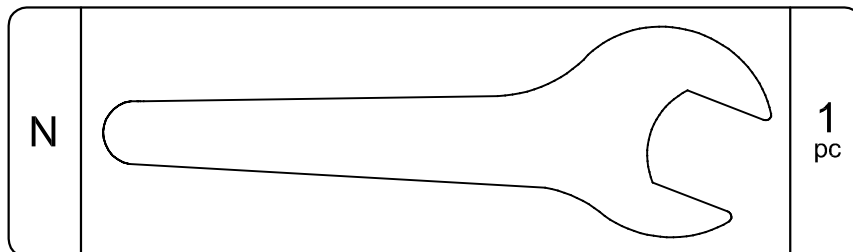
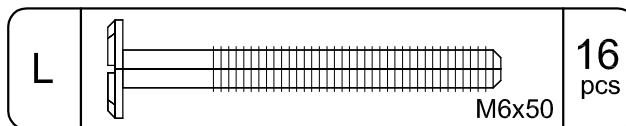
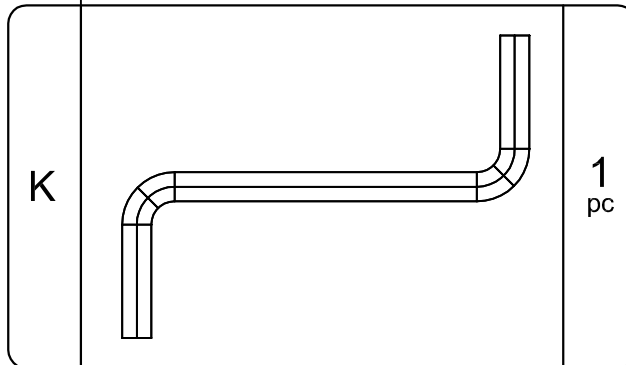
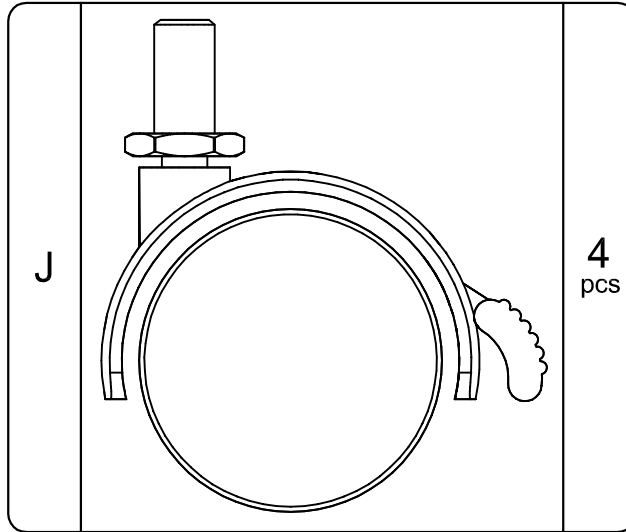
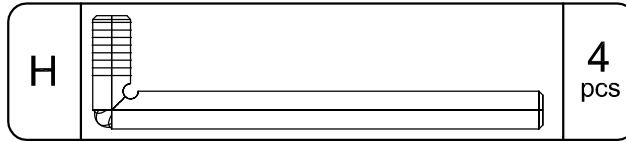
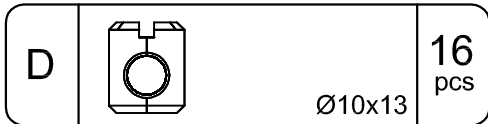
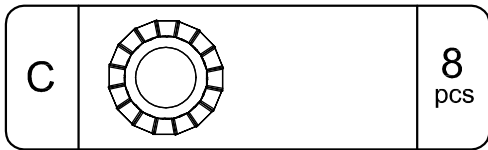
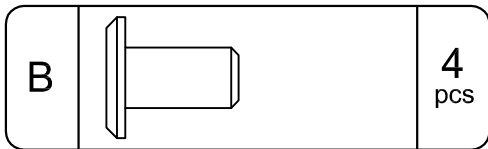
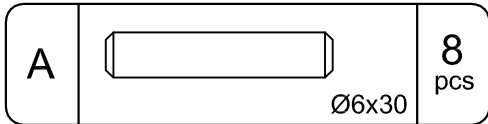

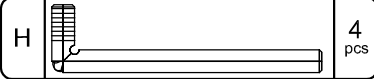
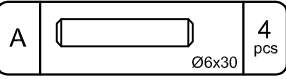

1

x2

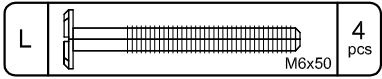
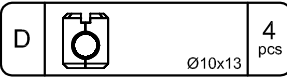
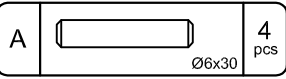
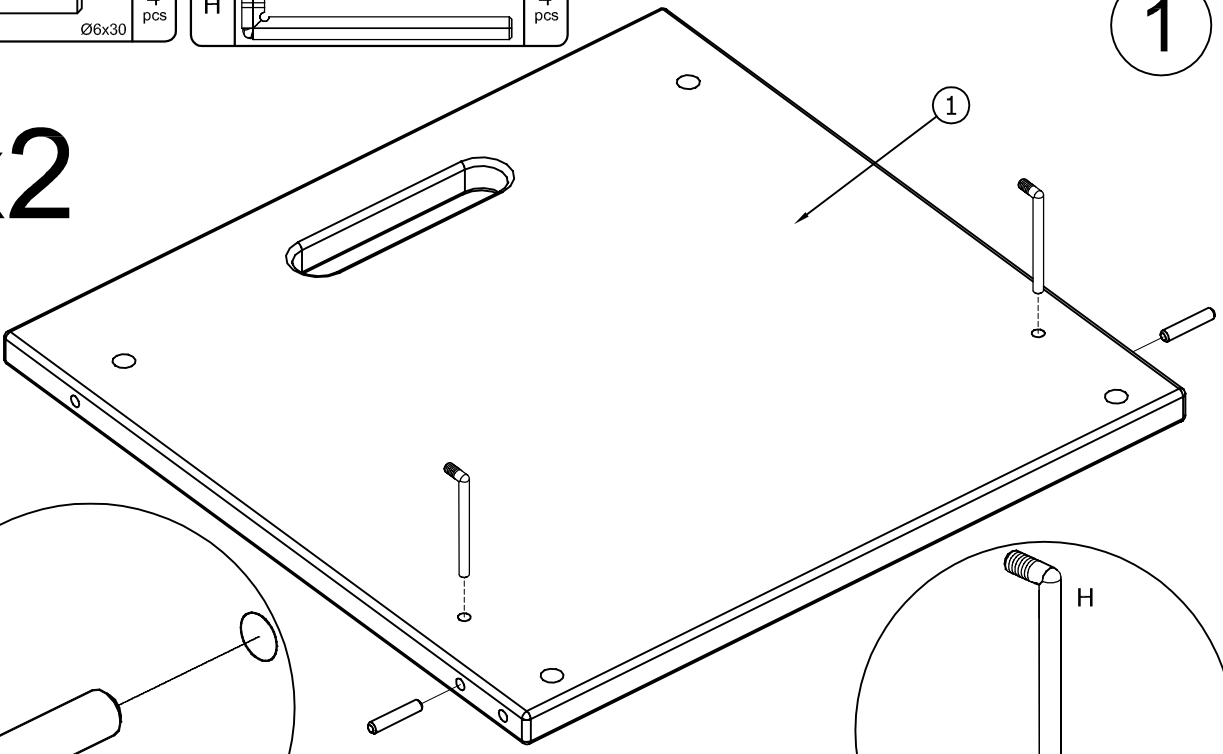

2

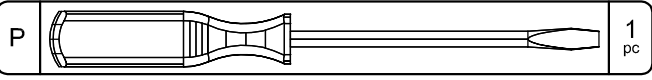

x2

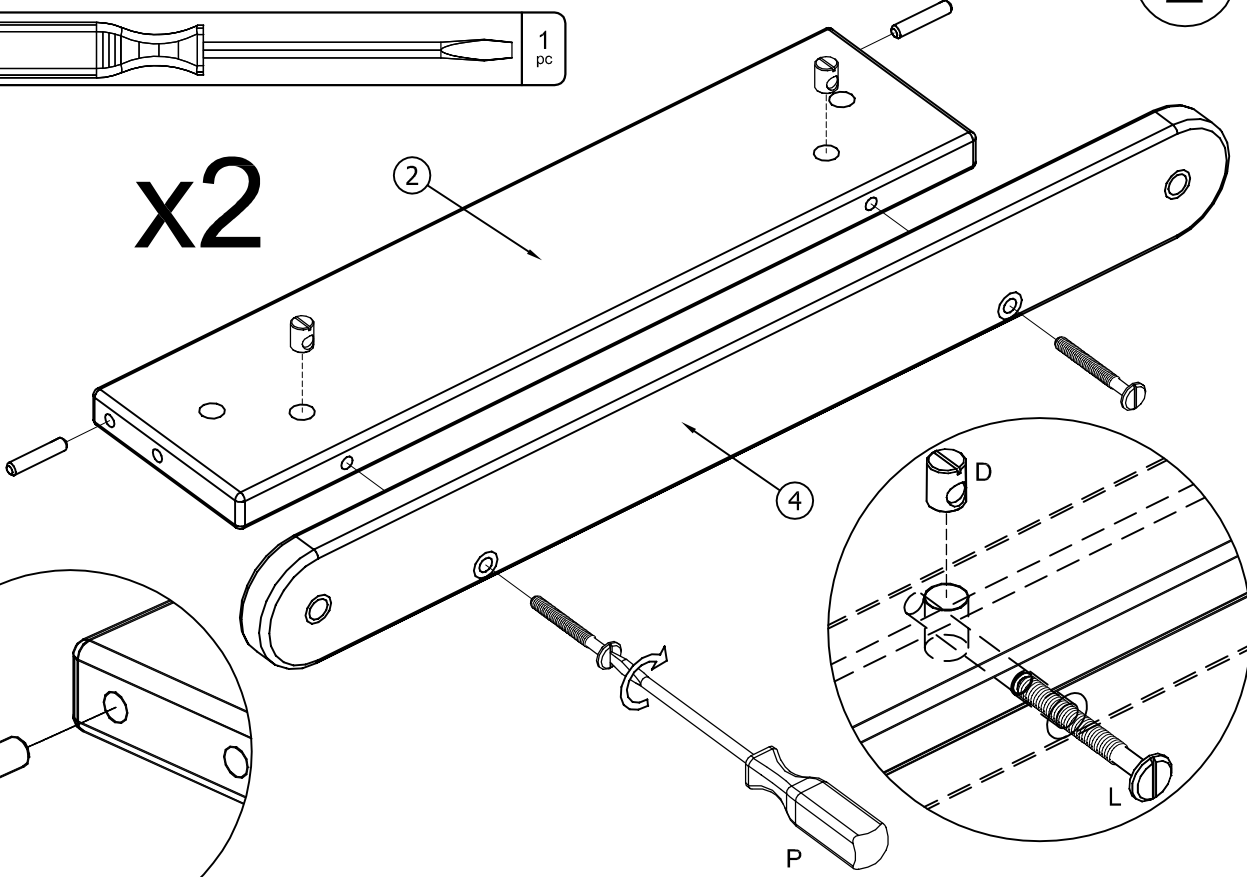

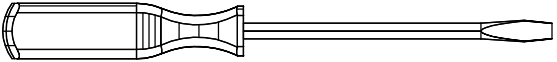

D  12 pcs
Ø10x13

L  12 pcs
M6x50

P  1 pc

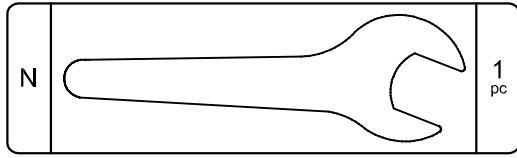
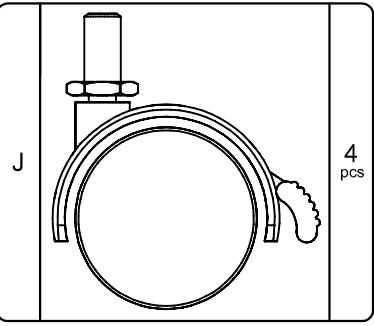
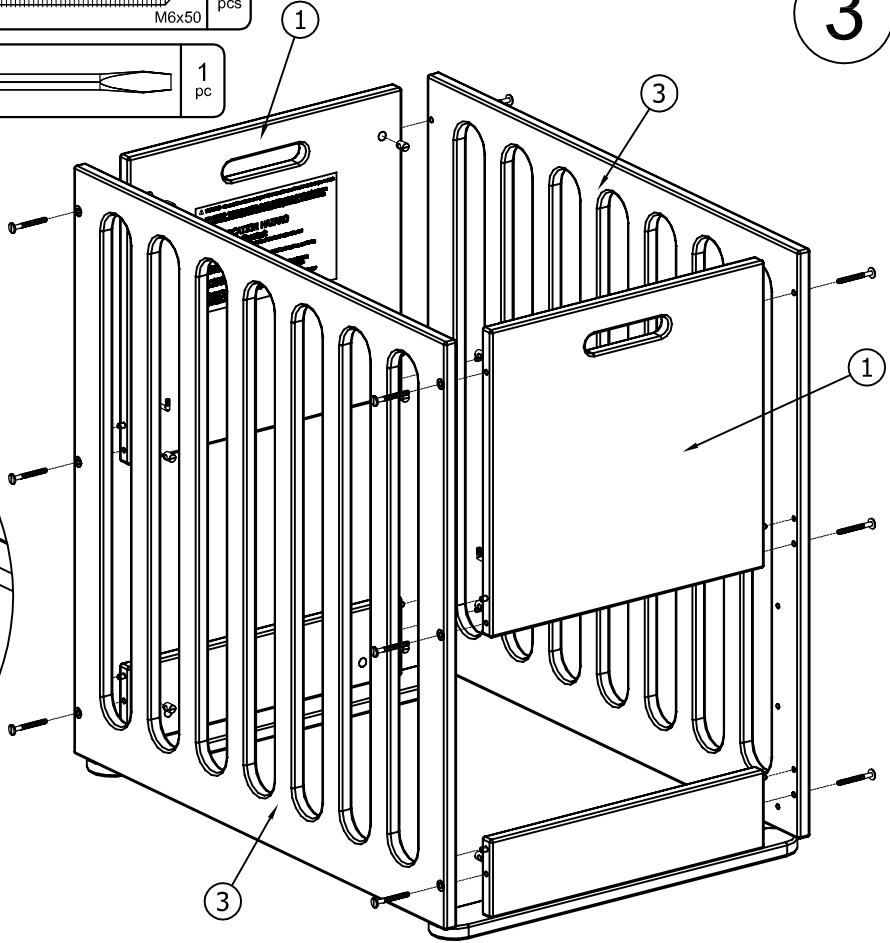
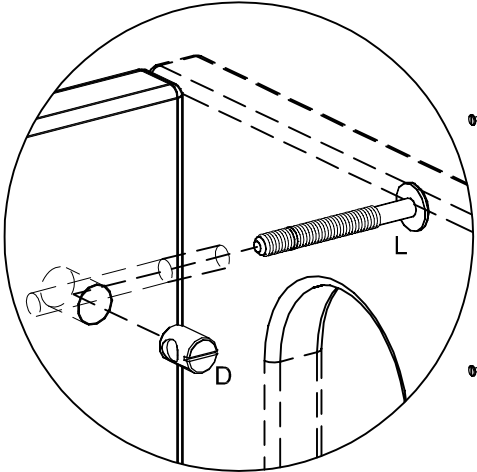
3



C  4 pcs

4

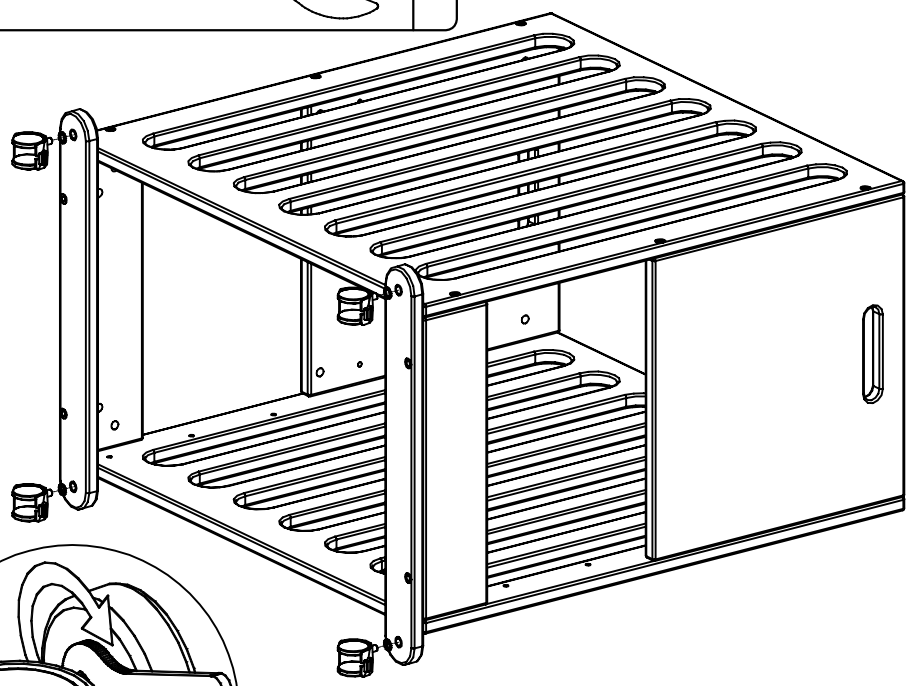
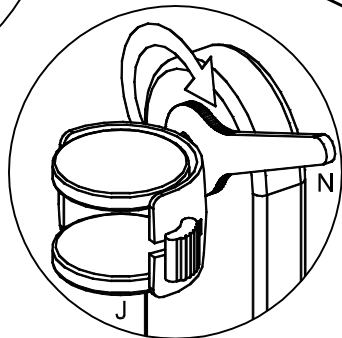
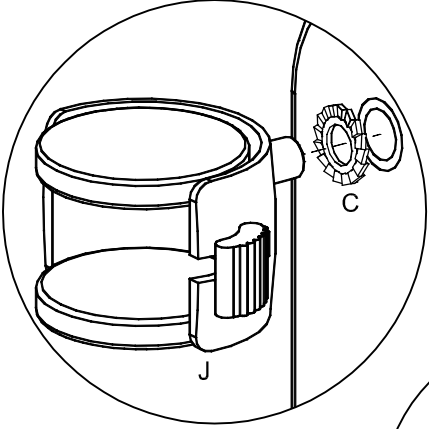

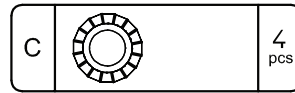
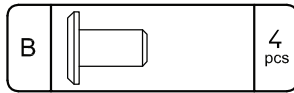
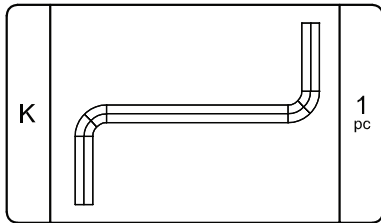

5

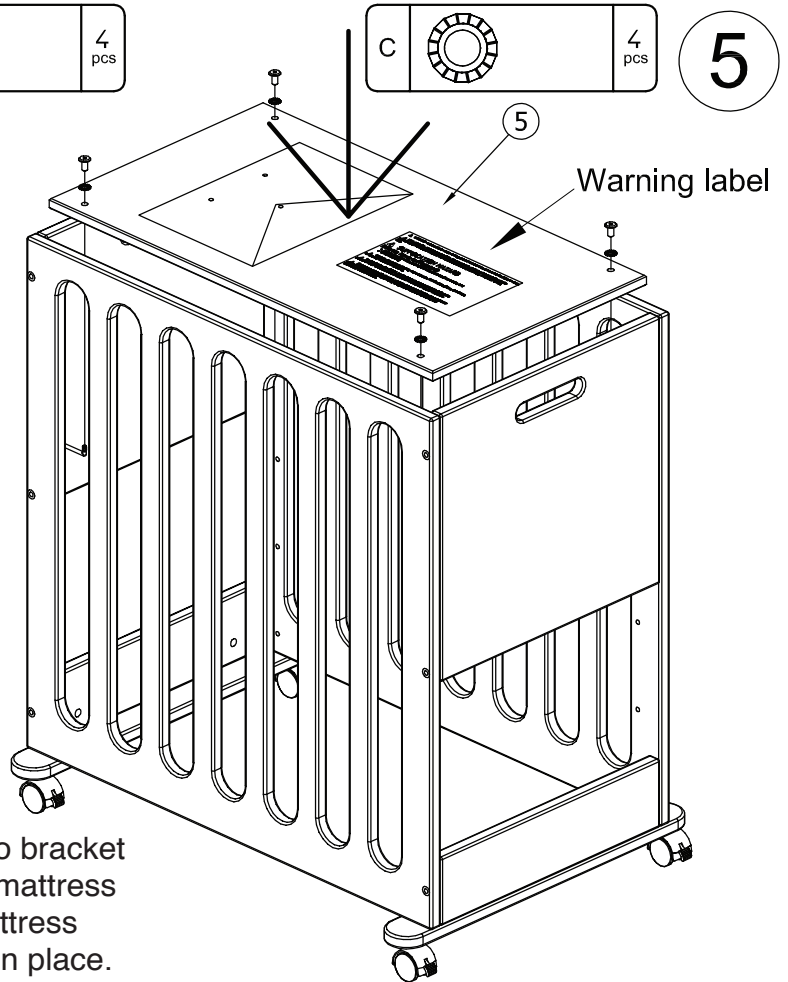
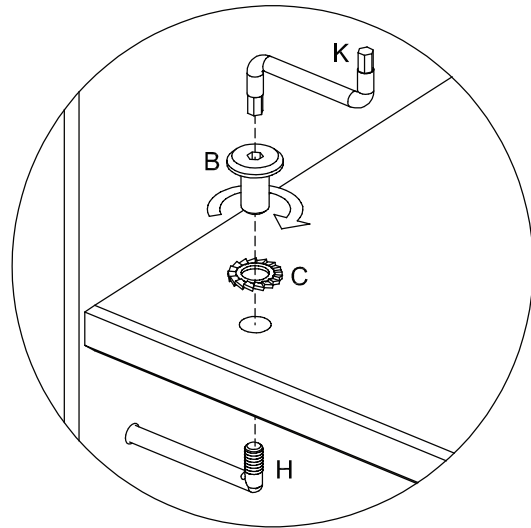

Check that nut “B” is fully threaded on to bracket “K” by pulling up on each corner of the mattress support (part 9) after assembly. The mattress support should feel secure and remain in place.

6

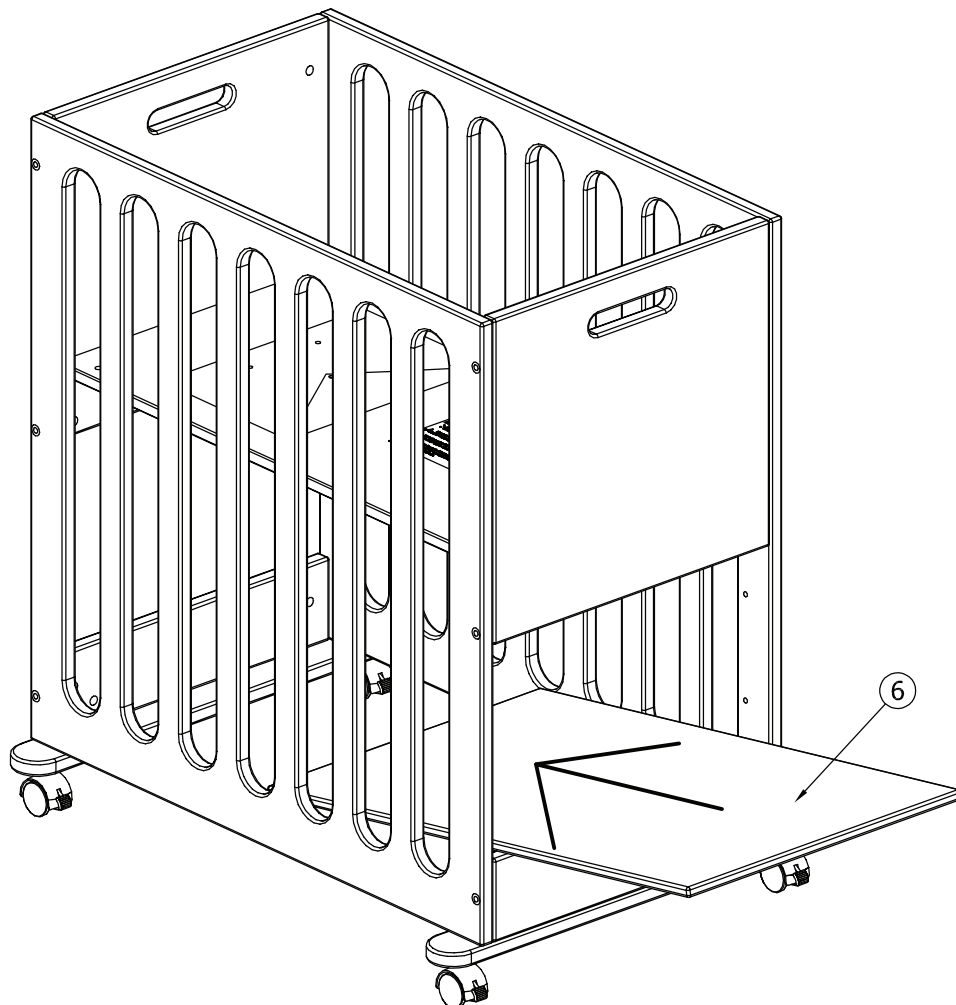

WARNING

Failure to follow these warnings and the assembly instructions could result in serious injury or death.

Read all instructions before assembling crib. Keep instructions for future use.

Never use plastic shipping bags or other plastic film as mattress covers because they can cause suffocation.

Infants can suffocate in gaps between crib sides and a mattress that is too small.

Infants can suffocate on soft bedding. Never add a pillow or comforter. Never place additional padding under an infant.

To reduce the risk of **SIDS**, pediatricians recommend healthy infants be placed on their backs to sleep, unless otherwise advised by your physician.

Strangulation Hazard:

- Strings can cause strangulation! DO NOT place items with a string around a child's neck, such as hood strings or pacifier cords.
 - DO NOT suspend strings over a crib or attach strings to toys.
 - To help prevent strangulation tighten all fasteners. A child can trap parts of the body or clothing on loose fasteners.
 - DO NOT place crib near window where cords from blinds or drapes may strangle a child.
-

Fall Hazard:

- When child is able to pull to a standing position, set mattress to lowest position and remove bumper pads, large toys and other objects that could serve as steps for climbing out.
- Stop using crib when child is able to climb out or reaches the height of 35 in. (89 cm).
- Check this product for damaged hardware, loose joints, loose bolts or other fasteners, missing parts, or sharp edges before and after assembly and frequently during use.
- Securely tighten loose bolts and other fasteners.
- DO NOT use crib if any parts are missing, damaged or broken.
- Contact Oeuf LLC for replacement parts and instructional literature if needed.
- DO NOT substitute parts.
- If refinishing, use a non-toxic finish specified for children's products.
- Follow warnings on all products in a crib.

CAUTION: ANY MATTRESS USED IN THIS CRIB MUST BE AT LEAST 27-1/4 INCHES BY 51-5/8 INCHES WITH A THICKNESS NOT EXCEEDING 6 INCHES.

WARNING

- Do not use this crib if you cannot exactly follow the instructions that come with it.
- Do not use this crib for a child who can climb out of it or who is taller than 90 cm.
- Do not place any cord, strap or similar item in or near this crib that could become wrapped around a child's neck.
- Do not place this crib near a window or patio door where a child could reach the cord of a blind or curtain and be strangled.
- Check this crib regularly before using it, and do not use it if any part is loose or missing or if there are any signs of damage. Do not substitute parts. Contact the manufacturer if replacement parts or additional instructions are needed.
- Children can suffocate on soft bedding. Do not place pillows, comforters or soft mattresses in this crib.

WARNING

Use a mattress that is no thicker than 15 cm and is of such a size that, when it is pushed firmly against any side of this crib, it does not leave a gap of more than 3 cm between the mattress and any part of any other side of the crib.

MISE EN GARDE

- Ne pas utiliser ce lit d'enfant à moins d'être en mesure de suivre précisément les instructions qui l'accompagnent.
- Ne pas utiliser ce lit d'enfant si l'enfant est capable d'en sortir ou mesure plus de 90 cm.
- Ne pas mettre dans ce lit d'enfant ou à proximité de celui-ci des cordes, sangles ou objets semblables qui risqueraient de s'enrouler autour du cou de l'enfant.
- Ne pas placer ce lit d'enfant près d'une fenêtre ou d'une porte-fenêtre où l'enfant pourrait saisir les cordes d'un store ou d'un rideau et s'étrangler.
- Vérifier régulièrement ce lit d'enfant préalablement à son utilisation et ne pas l'utiliser si une pièce est desserrée, une pièce est manquante ou s'il y a un signe de dommages. Ne pas substituer une pièce à une autre. Communiquer avec le fabricant pour obtenir, au besoin, une pièce de rechange ou des instructions supplémentaires.
- Les articles de literie mous présentent un risque de suffocation pour l'enfant. Ne pas mettre d'oreiller, d'édredon ou de matelas mou dans ce lit d'enfant.

MISE EN GARDE

Utiliser un matelas dont l'épaisseur est d'au plus 15 cm et dont la superficie permet d'empêcher, lorsqu'il est poussé fermement contre un côté quelconque de ce lit d'enfant, qu'un espace de plus de 3 cm soit créé entre le matelas et une partie quelconque de tout autre côté.

WARNING: TO PREVENT FALLS THE MATTRESS BASE OF THIS COT SHOULD BE ADJUSTED TO THE LOWEST POSITION BEFORE THE CHILD CAN SIT UP

RECOMMENDED MATTRESS SIZE This cot has been manufactured for use with a mattress which measures 700 mm wide by 1300 mm long and 120 mm in thickness.

The width and length are specified because it is important that the gaps between the mattress and the sides and ends of the cot will not exceed 40 mm. This is to minimize the risk of a child's limb becoming caught in the gap.

The thickness of the mattress has been specified to ensure that the depth of the cot is greater than 500 mm with the mattress base in the lower position to minimize the risk of a child climbing or falling out of the cot.

- FAILURE TO FOLLOW THESE WARNINGS AND THE ASSEMBLY INSTRUCTIONS COULD RESULT IN SERIOUS INJURY OR DEATH.
- BEFORE EACH USAGE OR ASSEMBLY, INSPECT COT FOR DAMAGED HARDWARE, LOOSE JOINTS, MISSING PARTS OR SHARP EDGES. DO NOT USE COT IF ANY PARTS ARE MISSING OR BROKEN. ASK YOUR DEALER OR WRITE TO KIDO AGENCIES FOR REPLACEMENT PARTS AND INSTRUCTIONAL LITERATURE IF NEEDED. DO NOT SUBSTITUTE PARTS.
- WHEN CHILD IS ABLE TO CLIMB OUT OR REACH THE HEIGHT OF 90 CM , THE COT SHALL NO LONGER BE USED.
- ENSURE THE COT IS PLACED AT A REASONABLE DISTANCE FROM CURTAINS, BLINDS, HEATERS AND POWER POINTS.
- KEEP MEDICATION, STRING, ELASTIC, SMALL TOYS OR SMALL ITEMS, SUCH AS MONEY, OUT OF REACH FROM ANY POSITION IN THE COT.
- IF REFINISHING, USE A NON-TOXIC FINISH SPECIFIED FOR CHILDREN'S PRODUCTS.
- DO NOT USE A WATER MATTRESS WITH THIS COT
- UPON COMPLETION OF ASSEMBLY, BE SURE ALL SCREWS AND BOLTS HAVE BEEN TIGHTENED SECURELY.
- A PERIODIC CHECK SHOULD BE MADE OF ALL SCREWS AND BOLTS AND RETIGHTENED IF NECESSARY.
- NEVER USE PLASTIC SHIPPING BAGS OR OTHER PLASTIC FILM AS MATTRESS COVERS BECAUSE THEY CAN CAUSE SUFFOCATION.
- DO NOT DRAG COT.
- AFTER COT HAS BEEN COMPLETELY ASSEMBLED, STORE INSTRUCTION SHEET IN THIS POUCH.
- UNDER NO CIRCUMSTANCES SHOULD THIS WARNING BE REMOVED FROM MATTRESS SUPPORT!

⚠️ 중요: 주의사항

- 제품을 안전하고 올바르게 사용하여 사고나 위험을 막기위한 것이므로 끝까지 읽어주십시오. 유아용침대 조립전에 사용설명서를 다 읽어주십시오. 이 사용설명서를 함께 동봉된 비닐과 함께 보관하세요.
- 절대로 플라스틱백 혹은 플라스틱 필름으로 된 매트리스 커버를 사용하지 마십시오. 영아질식 사의 원인이 될 수 있습니다.
- 매트리스가 침대보다 작은 경우, 그 틈새가 영아질식의 원인이 될 수 있습니다.
- 폭신한 이불은 영아질식의 원인이 될 수 있으므로, 베개나 폭신한 이불은 사용하지 마십시오. 보건의료 전문가 및 연구자는 영아돌연사 및 수면관련 사망 위험요인 감소를 위해 영아들을 눕혀 재울 수 있도록 권고하고 있습니다.

죄임 위험:

- 침대에서 사고로 인한 목조임 사망은 영아돌연사의 한 형태입니다. 절대로 침대주위에 아기의 목이 걸릴 수 있는 전선, 줄, 혹은 옷에 달린 끈 등을 두지 마십시오.
- 침대위에 끈을 연결하거나 침대와 장난감을 연결하지 마십시오.
- 죄임을 방지하기 위해 모든 조일수 있는 것들은 꼭 조여주십시오. 느슨하게 조여진 것들에 유아의 신체 일부나 옷 등이 끼일 수 있습니다.
- 유아의 몸에 줄이 감길 수 있으므로 크립을 창가 근처의 블라인드 줄이나, 각종 줄이 있는 곳에 크립을 절대로 두지 마십시오.

낙상 위험:

- 아기가 혼자 설 수 있을 때가 되었을 때, 매트리스를 가장 낮은 위치에 두고, 범퍼패드를 제거해 주시고 바닥에 큰 인형이나, 다른 계단이 될만한 물체를 침대 밑에 설치해 주셔서 아이가 안전하게 내려올 수 있도록 해주십시오.
- 아이가 침대에서 자유롭게 오르고 내려올 시기가 되면 사용을 멈춰주십시오. 혹은 아이가 키 89cm 이상 이 된다면 사용을 멈춰주십시오.
- 조립 혹은 사용전에 혹시 손상된 곳이 있는지, 없어진 부품이 있는지, 날카로운 곳은 없는지 확인합니다. 만약 없어진 부품이나, 손상된 곳이 있다면 절대로 사용하지 마시고 구입하신 구입처에 확인을 하거나 우프 수입판매 업체로 연락주십시오. 절대로 우프 이외의 부품을 대용해서 사용하지 마십시오.
- 침대를 관리하실 때에는 독한 화학제품이 포함되지 않은 어린이에게 비독성 제품을 사용해서 관리해 주십시오
- 이 주의사항들은 우프 모든 침대 제품에 해당됩니다.

- 경고: 유아용침대의 상부에서 최소 200 mm 아래에 매트 리스의 상단이 위치하여야 하며, 매트리스 지지대의 가장 낮은 위치일 경우에는 침대 상부에서 최소 500 mm 아래에 매트리스의 상단이 위치하여야 함.

관리 및 손질

- 침대를 관리하실 때 독한 화학제품이 들어가지 않은 비독성 제품으로 관리해주세요. 또한 순 한 가구 청소 제품에 물을 섞어서 아주 소량의 양만 마른헹겜으로 가구 표면을 닦아주십시오.
- 가구를 절대로 끌거나 미는 일이 없도록 해주십시오. 침대 아랫부분의 손상을 가지고 올 수 있습니다. 침대를 옮기실 때는 항상 들어서 옮겨주십시오.
- 직사광선을 피하고, 습기가 적당한 장소에 보관해 주십시오. 에어컨 코드가 있는 곳이나, 히터, 혹은 방열기가 있는 곳을 피해 설치해 주십시오. 극심한 습기 차이나 온도 차이는 가구를 손상시킬 수 있습니다.
- 직사광선은 가구의 색상의 변색이나, 가구 갈라짐 혹은 마감재 갈라짐 현상등이 있을 수 있습니다. 또한 흰색 계열의 가구제품들은 자연적으로 색상바램이 있을 수 있습니다. 이런 현상들은 제품 자체에 이상이 있는 것이 아닙니다.
- 만약이 침대를 창고에 보관해야 한다면, 습기가 많고 축축한 곳이나 온도가 높은 곳에 보관하지 마십시오. 적절히 환풍이 되는 곳에 보관하시고 절대로 가구위에 무거운 제품이나 다른 물건을 쌓아서 보관하지 마십시오.

점검 목록

- 손상된 곳이 없는지 사용전 항상 체크하시고 사용해 주십시오.
- 손상된 곳이 있는 상태의 제품은 절대로 사용하지 마십시오.
- 정기적으로 나사와 볼트가 꼭 조여졌는지 체크하시고 사용해 주십시오.

서비스 안내

사용 중 불편사항이나, 제품에 이상이 생겼을 경우, 혹은 부품이 필요하신 경우 저희 우프로 연락주십시오. 이 밖에 문의사항도 저희 이메일 j2international@oeufkorea.kr로 연락주십시오. 우프 신상품에 관한 정보는 본사 홈페이지 www.oeufkorea.kr를 확인하실 수 있습니다.

고객님의 제보나 고객의 소리는 저희 우프를 한 단계 발전시킬 수 있는 밑거름이 됩니다. 저희 우프제품에 대한 고객님의 제보는 저희 이메일 j2international@oeufkorea.kr로 보내주십시오.

Care & Maintenance

- When cleaning your cot, use a non-toxic, non abrasive cleaner. Mix a solution of water with a small amount of a mild detergent. Apply to bed surface with a damp cloth.
- When moving the cot without castors assembled, always lift the unit. Do not push or drag it to avoid damaging the base.
- It is important that the humidity levels in the room be controlled from extremes of too much humidity or too little. The bed should not be placed directly next to air-conditioning, outlets, fire places, radiators, space heaters, humidifiers, or dehumidifiers.
- Exposure to extreme variations of temperature and humidity can damage wood products.
- Keep the bed out of direct sunlight. UV rays may fade colors and in some cases darken them. It can cause crazing or hair line cracks in the finish. White finishes will darken naturally over time and exposure to direct sunlight will hasten this natural process along with some wood darkening; this is not considered to be a quality defect.
- If you need to put your cot in storage for any period of time do not store it in a damp or hot environment. Allow air flow around the furniture and do not stack anything on it.

Check List

- Always check the bed is free from damage before use. Do not use product if any damage is present.
- Regularly check that all assembly fittings are always tightened properly and retighten as necessary.
- Do not over-tighten fittings.

Sales Service

When you receive your Oeuf product, if you need assistance, spare parts or if you have any comments with respect to any aspect of the goods, please contact by email your **local retailer or distributor**.

In USA, please contact **help@oeufnyc.com**. You can also visit our website at **www.oeufnyc.com** for latest product information.

Parts List - Fawn Crib Only

Liste des Presentation

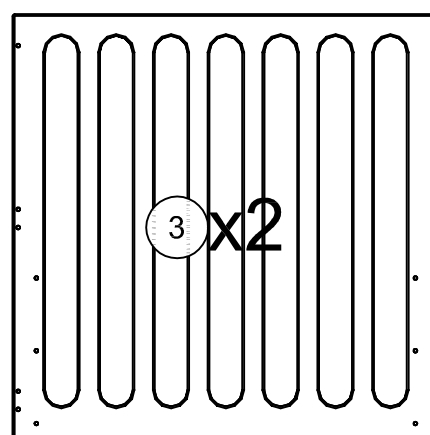
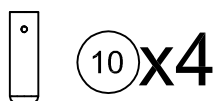
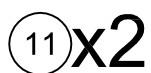
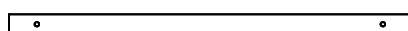
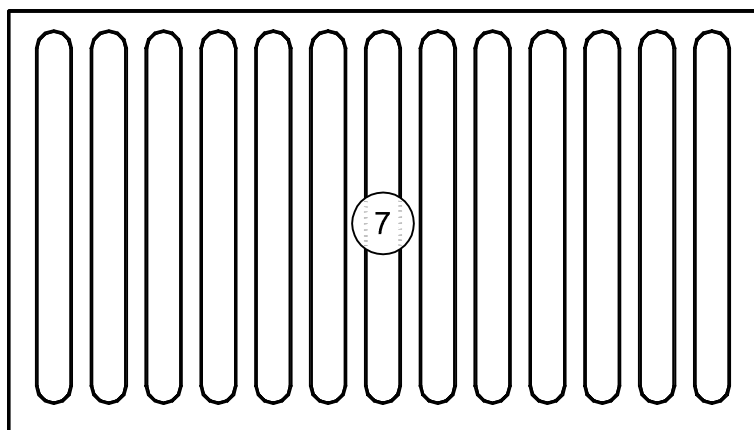
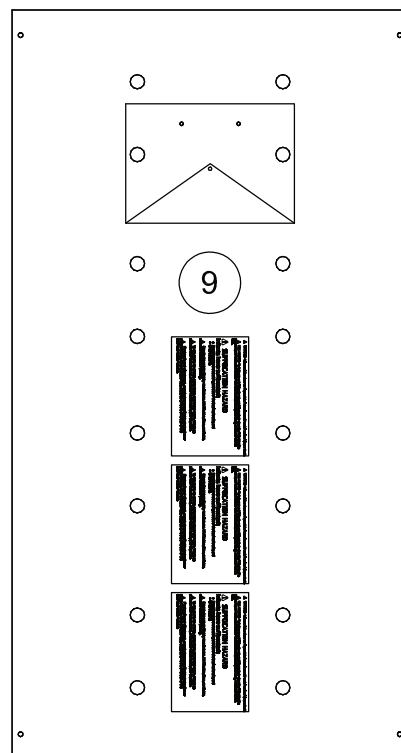
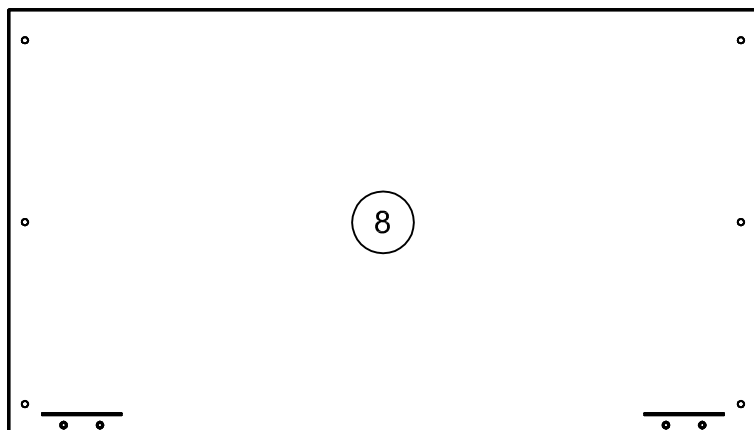

* Parts 3 are also used when assembling bassinets.

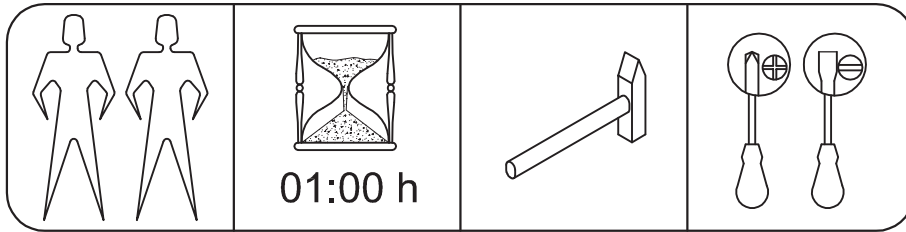

Fittings List - Fawn Crib Only

Liste des Pièces

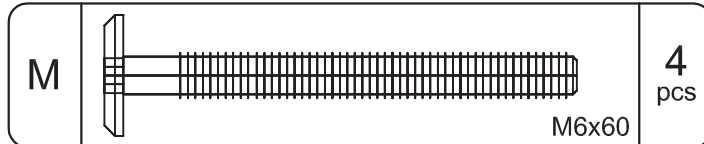
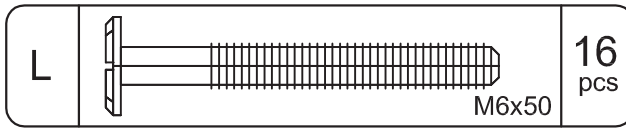
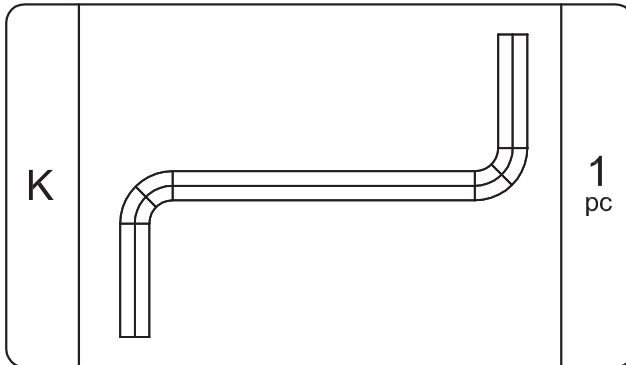
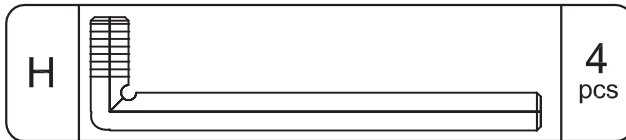
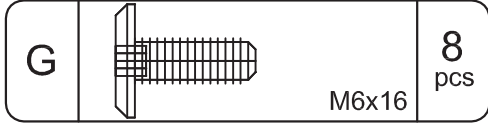
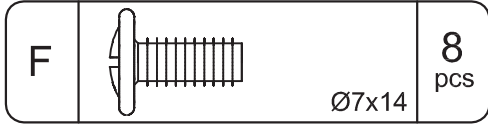
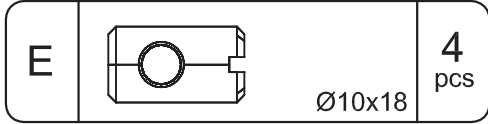
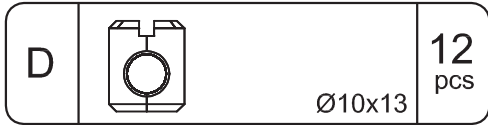
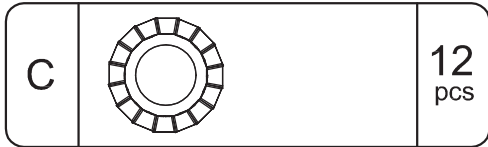
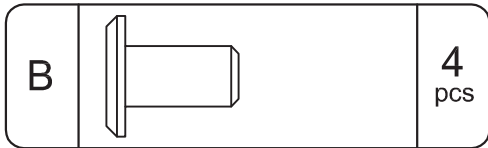
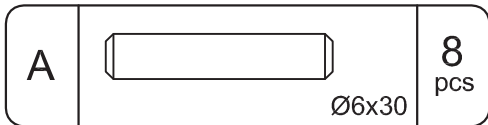

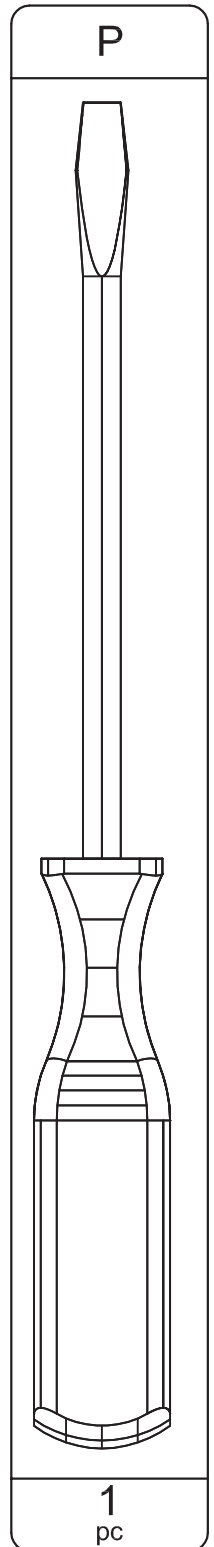

Please note:

Since some parts and fittings are used in both the bassinet and the crib, the two cannot be assembled at the same time.

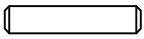

1

A  8 pcs
Ø6x30

G  8 pcs
M6x16

C  8 pcs

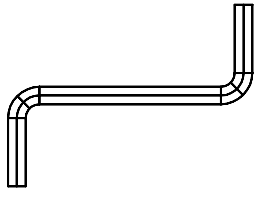
K  1 pc

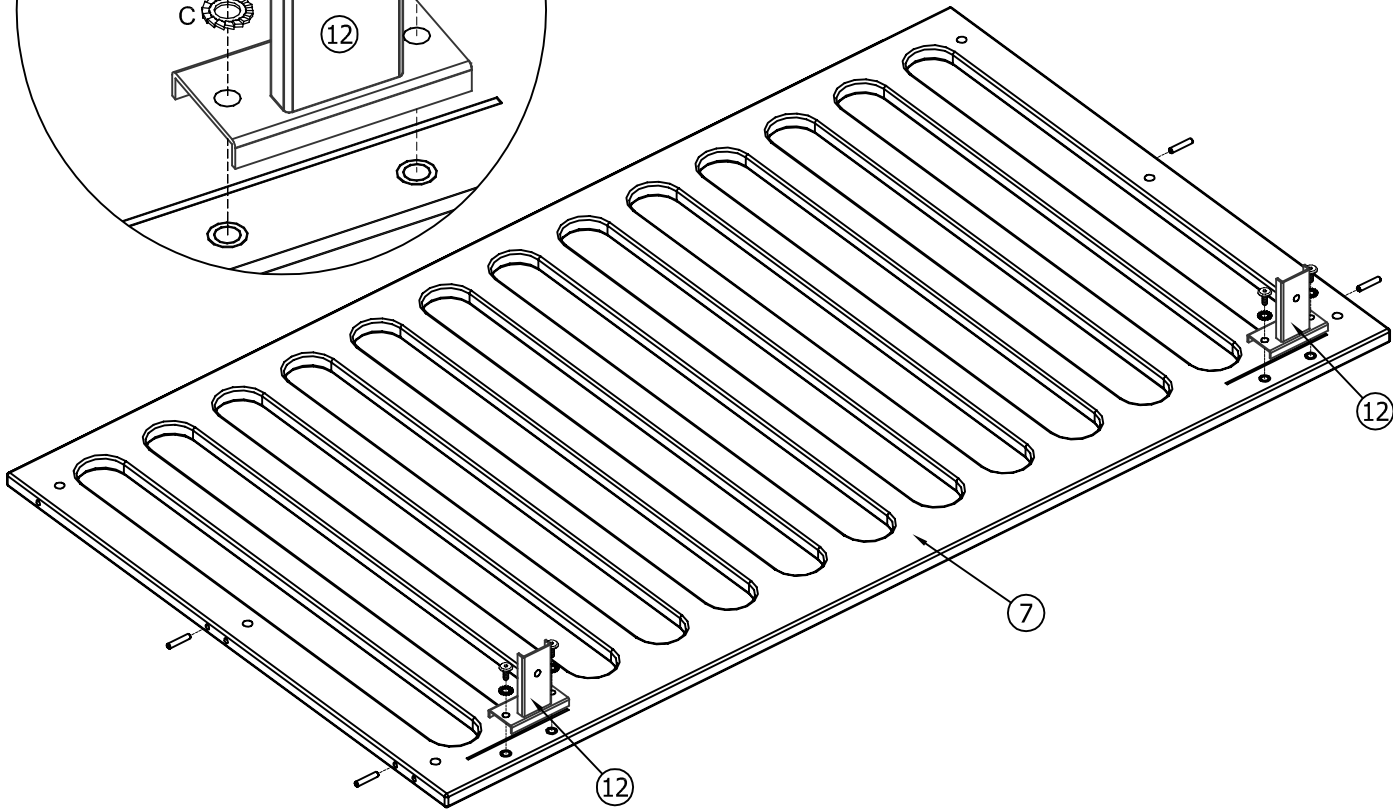
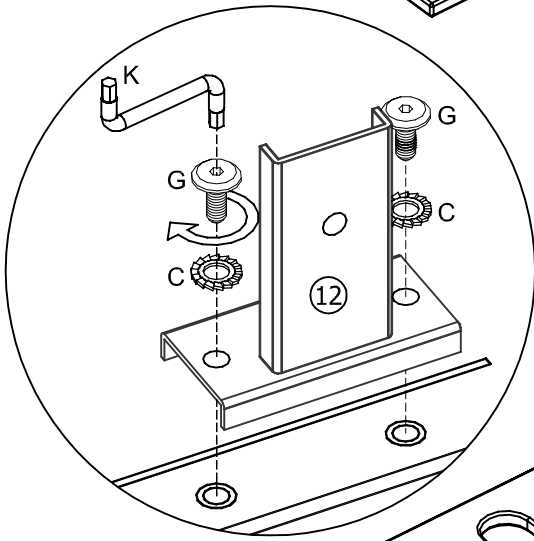
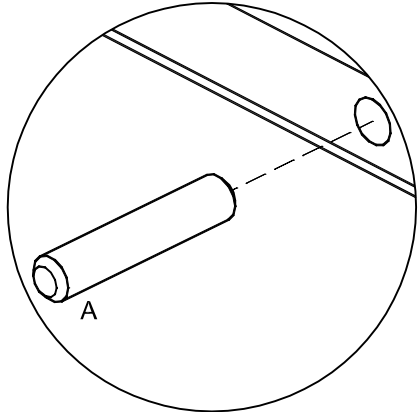
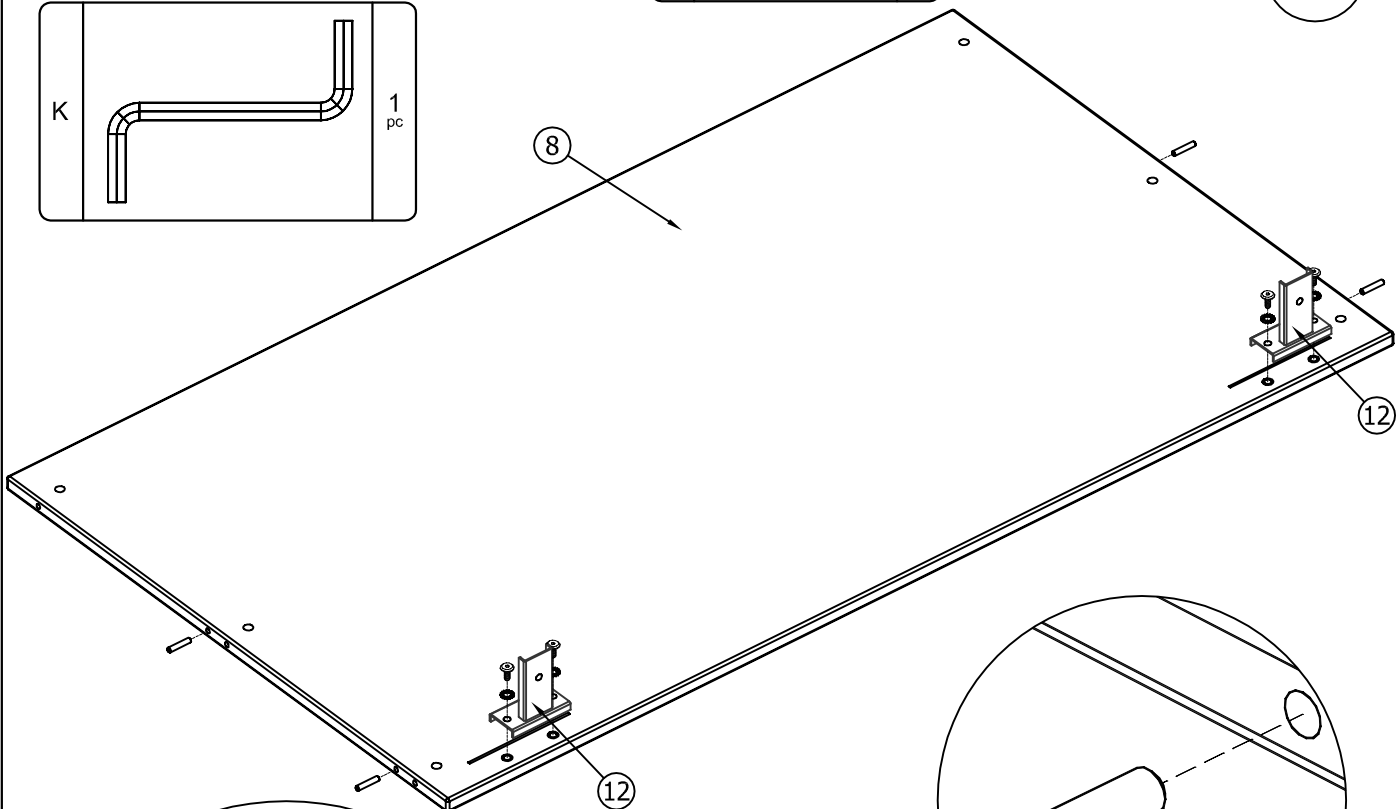

2

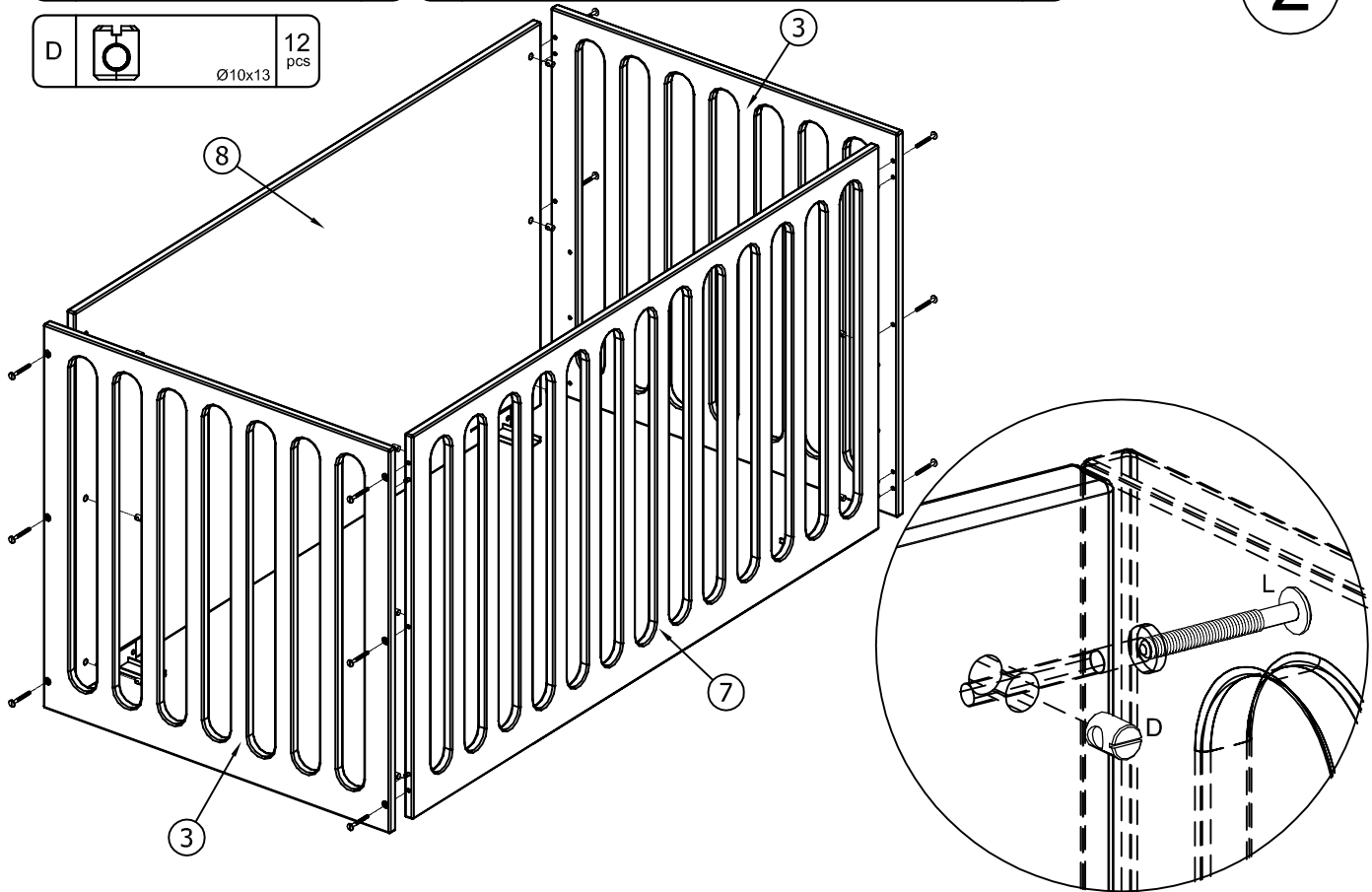
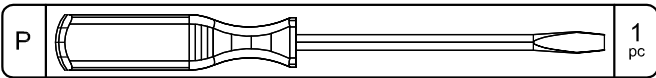

3

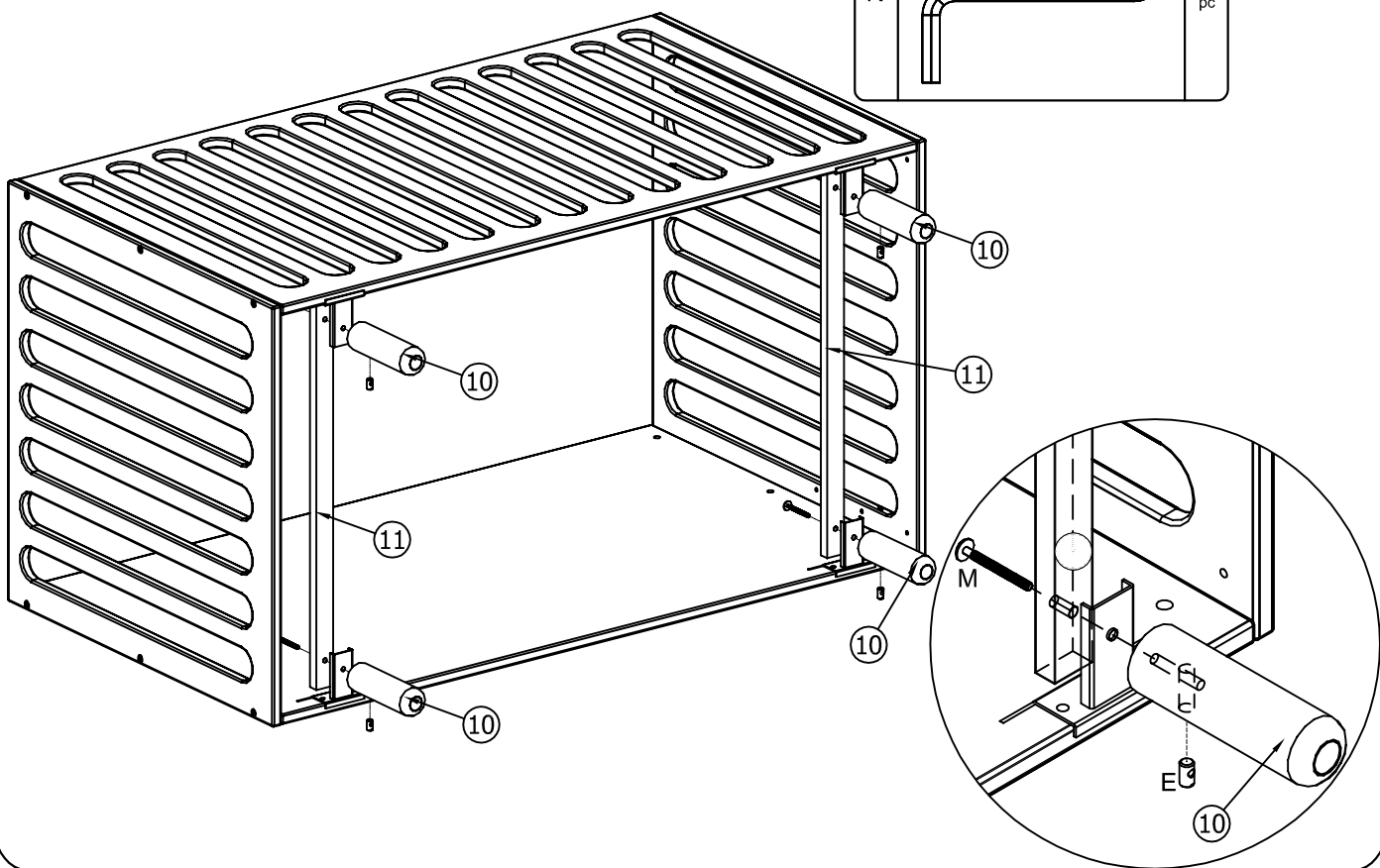
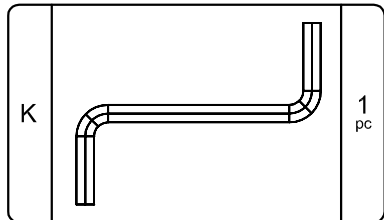
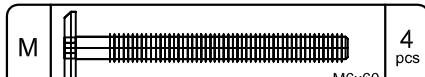
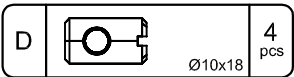

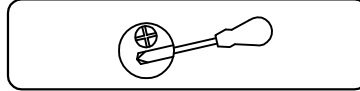
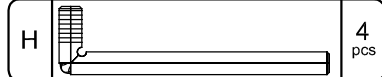

4

Insert mattress support brackets (H) into the holes for appropriate mattress height. To avoid possible finger entrapment, insert safety screws (F) into the remaining holes that are above the chosen mattress support position. The lowest mattress position is the safest position.

Use the lowest position when the child is able to sit up.

Inserer les pattes de soutien (H) de matelas pour la hauteur de matelas appropriée. Pour empêcher l'enfant de se coincer les doigts, entrer les vis de sécurité (F) dans les trous de soutien du matelas MOYEN et HAUT lorsque non utilisés. La position la plus basse de matelas est la plus sûre.

Utilisez la position la plus basse quand l'enfant peut s'asseoir tout seul.

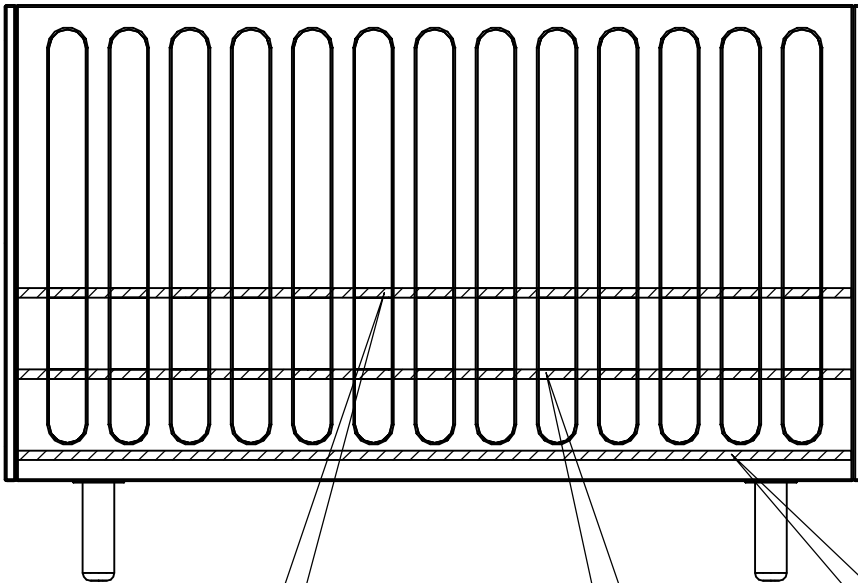

Middle position of mattress base not available in Australia, as per Australian regulations.

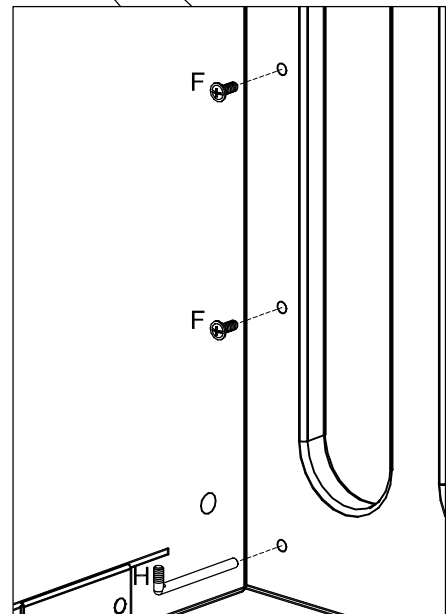
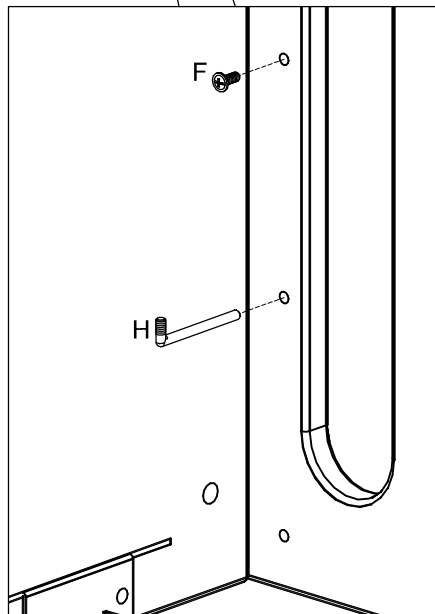
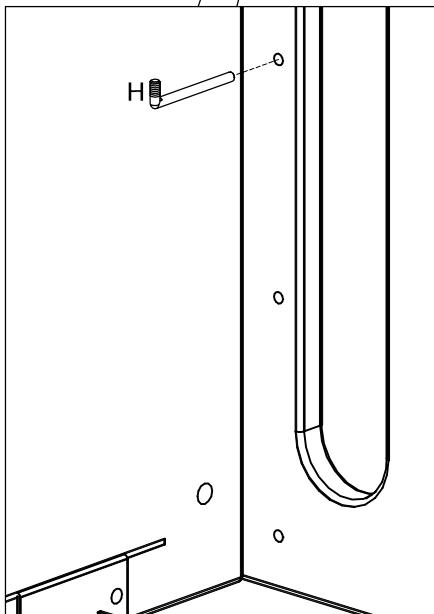

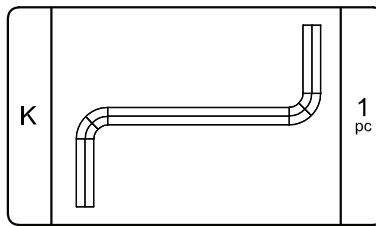
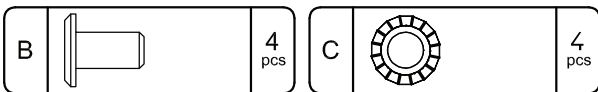
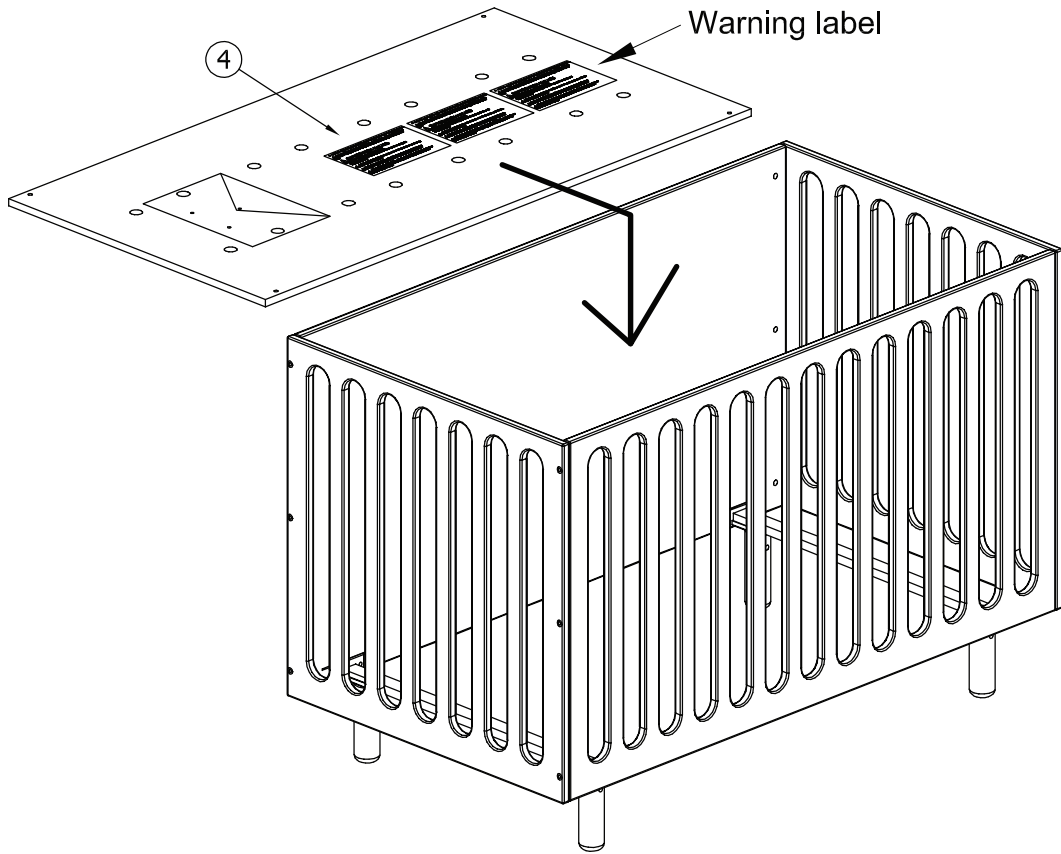

6

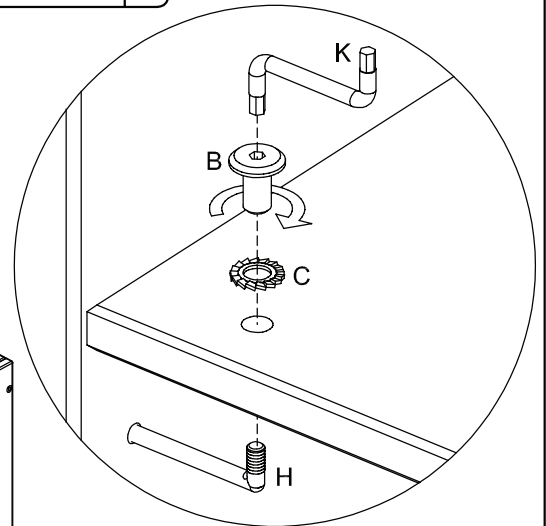
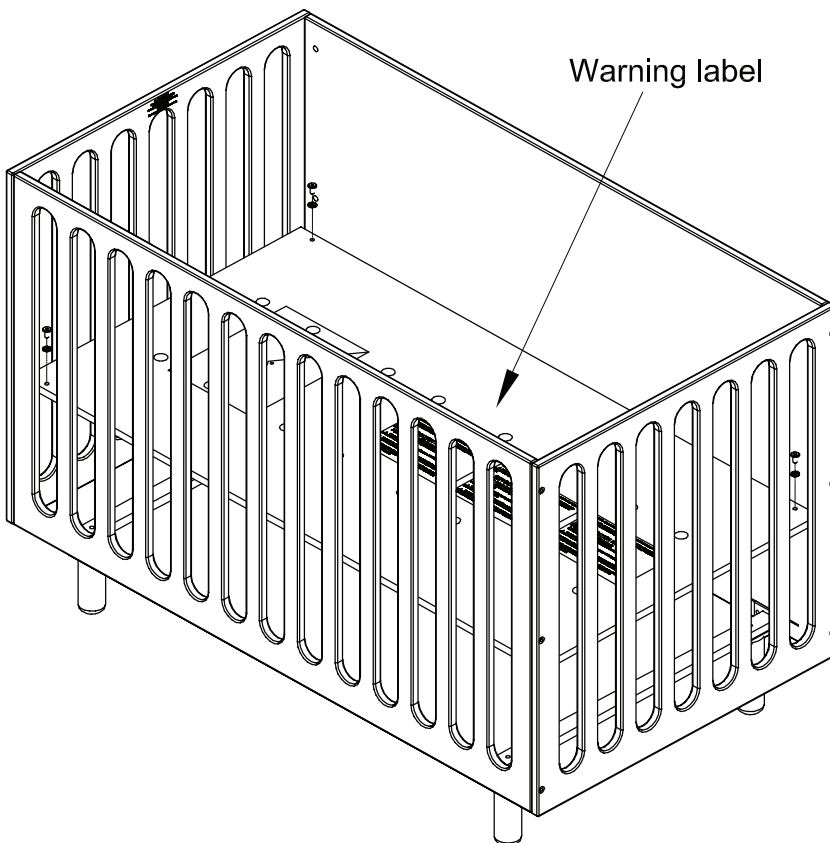

Check that nut "B" is fully threaded on to bracket "H" by pulling up on each corner of the mattress support (part 9) after assembly. The mattress support should feel secure and remain in place.