

Owner's Manual

HTP Air Plasma Cutting Systems

Micro Cut 625

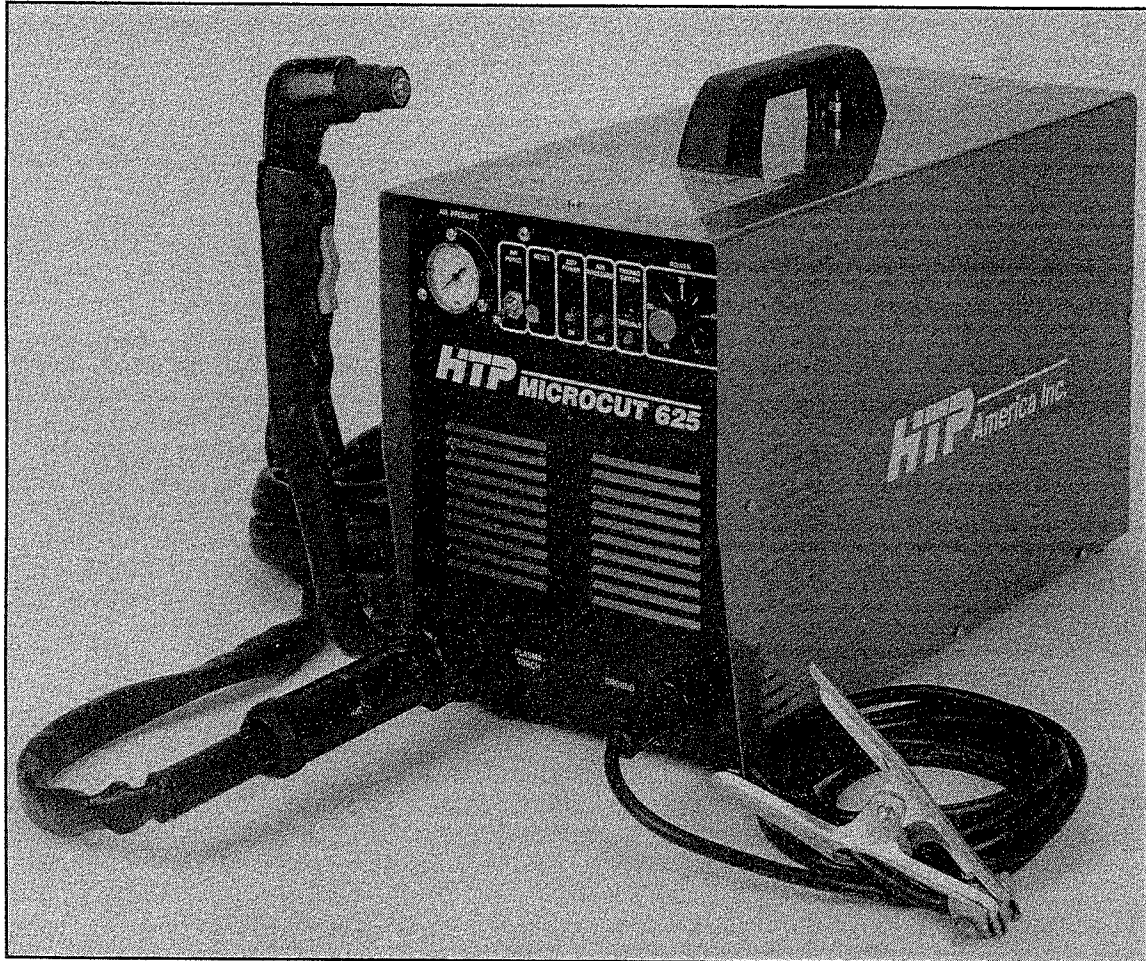

HTP America, Inc.
261 Woodwork Ln., Palatine, IL 60067
1-800-USA-WELD • 847-934-7060
FAX 847-934-7389

Table of Contents

Introduction	1
Limited Warranty	1
Safety Precautions	2
Inspection	4
Plasma/Cooling Gas Connection	4
Electrical Connection	5
Plasma Torch Connection	5
Ground Cable Connection	5
Front Panel Controls	6
Operation	8
Maintenance and Service	8
Cutting Tips	9
Parts Breakdown - Micro Cut 625	10
Wiring Diagram - Micro Cut 625	11
Wiring Diagram - Control Logic PCB	12
Wiring Diagram - Power PCB	13
Parts Breakdown - Plasma Torch	14
Trouble Shooting	15
Cutting Problems	15

Introduction

Congratulations on your purchase of an HTP America Micro Cut 625 Air Plasma Cutting System. Your purchase of a Micro Cut 625 means you have purchased one of the most technologically advanced, safest and economical plasma cutters available today.

The owner's manual has been designed to instruct you on the safe operation of your Micro Cut 625. If you read and follow the instructions in this manual, your plasma cutter will provide you with years of trouble free operation. If you fail to read and understand this manual, as well as correctly follow the operating instructions, you will significantly shorten the operating life of your plasma cutter.

Operation of your plasma cutting system without proper understanding of the facts contained within this manual or under unsafe or hazardous conditions, may lead to **SERIOUS INJURY OR DEATH!**

Limited Warranty

Subject to the terms and conditions hereof, HTP warrants to its Distributor/Dealer that all new and unused Equipment furnished by HTP is free from defect in workmanship and material as of the time and place of delivery by HTP. No warranty is made by HTP with respect to trade accessories or other items manufactured by others. Such trade accessories and other items are sold subject to the warranties of their respective manufacturers, if any.

Except as specified below, HTP's warranty does not apply to components having normal useful life of less than one (1) year, such as relay and contactor points.

HTP shall be required to honor warranty claims on warranted Equipment in the event of failure resulting from a defect within the following periods from the date of delivery of Equipment to the original user:

1. Plasma cutters, power sources and components: 1 year.
2. All plasma torches: 90 days.
3. The electrode, cutting nozzle, insulator, spring, and gas diffuser are consumable items, WHICH CARRY NO WARRANTY.

provided that HTP is notified in writing within thirty (30) days of the date of such failure.

As a matter of general policy only, HTP may honor claims submitted by the original user within the foregoing periods.

In the case of HTP's breach of warranty or any other duty with respect to the quality of any goods, the exclusive remedies therefore shall be, at HTP's option (1) repair or (2) replacement or, where authorized in writing by HTP in appropriate cases, (3) the reasonable cost of repair or replacement at an authorized HTP service station upon return of the goods at Customer's risk and expense. HTP's option of repair or replacement will be F.O.B., Factory at Palatine, Illinois, therefore; no compensation for transportation costs of any kind will be allowed. Upon receipt of notice of apparent defect or failure, HTP shall instruct the claimant on the warranty claim procedures to be followed.

HTP America, Inc. has reserved the right to make changes in design or add any improvements to its products at any time without incurring any obligation to install same on equipment.

This warranty is null and void unless warranty card is sent to HTP America, Inc. within 15 days from date of purchase.

ANY EXPRESS WARRANTY NOT PROVIDED HEREIN AND ANY IMPLIED WARRANTY, GUARANTY OR REPRESENTATION AS TO PERFORMANCE, AND ANY REMEDY FOR BREACH OF CONTRACT WHICH, BUT FOR THIS PROVISION, MIGHT ARISE BY IMPLICATION, OPERATION OF LAW, CUSTOM OF TRADE OR COURSE OF DEALING, INCLUDING ANY IMPLIED WARRANTY OF MERCHANTABILITY OR OF FITNESS FOR PARTICULAR PURPOSE, WITH RESPECT TO ANY AND ALL EQUIPMENT FURNISHED BY HTP IS EXCLUDED AND DISCLAIMED BY HTP.

Safety Precautions

WARNING: Before performing any installation or operating procedures read and follow the safety precautions listed below. Failure to observe these safety precautions can result in personal injury or death.

Personal Protection: Skin and eye burns resulting from body exposure to the electric-arc welding rays or hot metal can be more severe than sunburn:

- a. Use a proper face shield fitted with correct filter and cover plates to protect your eyes, face, neck and ears from sparks and rays of the cutting arc when cutting or observing cutting. WARN bystanders not to watch the arc or expose themselves to the welding-arc rays or hot metal.
- b. Wear flameproof gauntlet-type gloves, heavy long-sleeve shirt, cuffless trousers, high topped shoes and a welding helmet or cap for hair protection to protect the skin from arc rays and hot sparks or metal. A flameproof apron may also be desirable as protection against radiated heat and sparks.
- c. Hot sparks or metal can lodge in rolled up sleeves, trouser cuffs or pockets. Sleeves and collars should be buttoned, and pockets eliminated from the front of the clothing. Protect other nearby personnel from arc rays and sparks with a suitable non-flammable partition.
- d. Always wear safety glasses or goggles within the cutting area. Use safety glasses with side shields or goggles when chipping slag or grinding. Chipped slag is hot and can travel considerable distances. Bystanders should also wear safety glasses or goggles.

Fire Protection: Hot slag, or sparks, can cause serious fires when in contact with combustible solids, liquids or gases:

- a. Remove all combustible materials well away from the welding area or completely cover the materials with a non-flammable covering. Such combustible materials include wood, clothing, sawdust, gasoline, kerosene, paints, solvents, natural gas, acetylene, propane and similar combustible articles.
- b. Hot sparks or hot metals can fall into cracks in floors or wall openings and cause a hidden smoldering fire. Make certain that such openings are protected from hot sparks and metal. Do not weld, cut or perform other work on used barrels, drums, tanks or other containers until they have been completely cleaned.
- c. For fire protection, have fire extinguishing equipment handy for instant use. After completion of cutting, inspect the work area for hazardous hot sparks or metal.

Electrical Shock: Voltages in excess of 110V can cause severe burns or fatal shock. Severity of electrical shock is determined by the path and amount of current through the body:

- a. Never allow live metal parts to touch bare skin or wet clothing. When standing on metal or welding in a damp area you must be well-insulated. Wear dry gloves and rubber-soled shoes. Stand on a dry board or platform.
- b. Always ground the plasma cutter by connecting a ground wire between the machine and electrical ground. Do not use worn, damaged or overloaded welding cables. Use well maintained equipment.
- c. When not cutting, turn off the equipment. Accidental grounding can cause overheating and create a fire hazard. Do not coil or loop the welding cable around parts of your body. Be sure the ground cable is connected to the work piece as close to the cutting area as possible. Grounds connected to the building framework or remote locations increase the possibility of stray cutting currents.
- d. Keep everything dry; clothing, work area, welding cables, electrode holder, and cutting machine. Fix water leaks immediately.

Ventilation: Cutting fumes, particularly in confined places, can cause discomfort and physical harm if breathed over an extended period of time:

- a. Provide adequate ventilation by natural or mechanical means. Do not cut on galvanized zinc, lead, beryllium, or cadmium materials unless positive mechanical ventilation is provided!
- b. Do not cut in locations close to chlorinated hydrocarbon vapors from degreasing or spraying operations. Heat or arc rays react with solvent vapors forming phosgene, a highly toxic gas.
- c. If you develop momentary eye, nose or throat irritation during cutting, ventilation is not adequate. Stop work and take necessary steps to improve ventilation. Discontinue cutting if physical discomfort persists.
- d. Refer to AWS Standard Z49.1 in Item 6 for specific ventilation recommendations.

Equipment Maintenance: Faulty or improperly maintained plasma cutting equipment results in poor cut-quality. It can cause physical injury or death through fires or electrical shock.

- a. Whenever possible, have a qualified person perform the installation, troubleshooting and maintenance work on the plasma cutter. Do not perform any electrical work on the plasma cutter unless qualified to perform such work. Before performing any maintenance work inside the plasma cutter, disconnect the machine from the main electrical power source.
- b. Maintain plasma cutting cables, grounding wire and connections, power cord and plasma cutter in safe working order. Do not operate the plasma cutter or accessory equipment in faulty condition. Keep the equipment away from heat sources such as furnaces, wet conditions such as water puddles, oil or grease, corrosive atmospheres and inclement weather.
- c. Keep all safety devices and cabinet covers in position and in good repair. Use the plasma cutter for its intended purpose and do not modify it in any manner. Unauthorized maintenance repair will result in loss of warranty coverage.

Additional Safety Information:

- a. "Safety in Welding and Cutting" - AWS Z49.1
- b. "Recommended Safe Practices for Gas-Shielded Arc Welding" - AWS A6.1
- c. "Safe Practices for Welding and Cutting Containers that Have Held Combustibles" - AWS A6.0
- d. "Recommended Safe Practices for Plasma Arc Cutting" - AWS A6.3
- e. "Recommended Safe Practices for Plasma Arc Welding" - AWS C5.1

Inspection

After removing your plasma cutter from its shipping carton, inspect the plasma cutter for any concealed damage not seen upon receiving the unit. Any claims for loss or damage occurring during shipping must be filed by the purchaser with the freight company.

Check the inlet air supply at the rear of the cabinet to be sure no packing materials have gotten inside to obstruct the air flow to the plasma torch.

Plasma/Cooling Gas Connection

Your Micro Cut 625 has been designed to use clean, dry compressed air as both the plasma and cooling gas. Water and/or oil in the air will significantly reduce the life of the electrode and the cutting nozzle, at the same time reducing the quality of the cut.

Safety sensing circuitry has been installed to eliminate arc-initiation if the air pressure and volume are inadequate.

Damage to your plasma cutter due to excessive water and/or oil in the air supply line is not covered under warranty. Your Micro Cut 625 comes equipped with a regulator/filter. In addition, HTP has 2 filters available for removing any impurities from the air. If you already have a drier on your compressor, we recommend the HTP Super Dry (Part # 25300) which is a disposable in-line filter. This filter uses a desiccant to completely remove all moisture from the air. The desiccant is blue when new and turns clear when the filter needs to be discarded.

Plasma/Cooling Gas Pressure	Volume
60 to 75 psi	4 1/4 cfm

If you do not have a drier on your compressor, we strongly recommend the HTP Max Dry (Part # 25310). This is a 3 stage filter which completely removes all oil and water from the air. The first stage of the Max Dry removes the water which is present in the air. The second stage of the filter removes any oil which may be in the air along with particulate down to .03 microns. The final stage is the desiccant drier, which removes the humidity from the air. The desiccant in the final stage is reusable. It is blue when it is fresh, and changes to pink when it has absorbed moisture. Just put the pink desiccant in the oven to bake the moisture out and reuse. This filter extends the life of your air tools and is great for painting also.

WARNING: Check the air regulator set every day for proper pressure, volume and water/oil levels.

Electrical Connection

All electrical connections should be performed by a qualified electrician in accordance with the National Electrical Code and local codes and ordinances. When connecting your plasma cutter, the yellow-green wire **MUST BE CONNECTED TO GROUND, OR SERIOUS INJURY OR DEATH MAY RESULT!**

ELECTRICAL SHOCK CAN KILL! Do not connect an input wire to the ground terminal. Do not connect the ground (yellow-green or green) wire to an input (hot) line terminal. It is also strongly recommended that a fusible line disconnect switch be installed in the input power circuit to the plasma machine. This would provide a safe and easy method to remove all electrical power from your plasma system whenever it is necessary to perform internal inspection or servicing.

BEFORE ATTEMPTING TO MAKE ANY PRIMARY POWER CONNECTIONS TO YOUR PLASMA CUTTER, BE SURE THAT ALL POWER IS OFF BY OPENING THE LINE DISCONNECT SWITCH.

Your Micro Cut 625 has been designed to operate from 220 volt single phase power wired for a minimum of 30 amps. The green or yellow-green wire must be connected to ground. The blue and brown wires must be connected to the hot legs of the 220 volt power.

Plasma Torch Connection

Disconnect power from the machine. The plasma cutting torch on your Micro Cut 625 is a quick-disconnect design, allowing you to easily remove and install the cutting torch without any tools. This makes it very easy to transport your machine or service the cutting torch.

To install the cutting torch, insert the copper plug into the center of the adapter block mounted on the front of the plasma cutter. Rotate the plasma torch until the male plastic tab on the plasma torch fits into the cutout on the bottom of the adapter block. Firmly push the plasma torch into the adapter block and secure it by tightening the adapter nut until snug.

Ground Cable Connection

Connect the ground clamp as close to the workpiece as possible. This will reduce the possibility of current loss through stray paths. Always connect the clamp to clean, bare metal. Do not connect the ground clamp to the piece which will be cut off.

The ground cable is connected to the front of the machine. Plug the cable into the receptacle labeled "GROUND" and twist clockwise until tight.

FRONT PANEL CONTROLS



- 1) Air Pressure Gauge
- 2) Air Purge Switch
- 3) Reset Switch
- 4) Input Power Light
- 5) Air Pressure Light
- 6) Thermo Switch Light
- 7) Trouble Light
- 8) Cutting Power Adjustment
- 9) Plasma Torch Connection
- 10) Ground Cable Connection

1) AIR PRESSURE GAUGE - the air pressure Gauge measures the plasma gas pressure and should be set between 60 and 75 psi for optimum cutting performance. To adjust the plasma gas pressure, adjust the regulator at the rear of the machine while holding the air purge switch (2) to achieve the correct pressure while air is flowing through the plasma torch.

2) AIR PURGE SWITCH - the air purge switch allows you to purge air through the torch, allows you to manually cool the cutting torch after long periods of cutting, and allows you to set the air pressure while flowing air through the plasma torch.

To purge the torch, simply flip the toggle switch up. Air will start to flow. To stop the air flow, flip the toggle switch down.

3) RESET SWITCH - when the machine is turned on for the first time, the red trouble light will be illuminated. If the machine is connected to the correct power source, the correct air supply, and the torch is installed correctly; depressing the reset button will turn off the red trouble light and allow you to begin cutting.

4) INPUT POWER LIGHT - when the machine is correctly connected to a 220 volt input power supply, and the on-off switch at the rear of the plasma cutter is turned on, a green light will be illuminated, indicating your Micro Cut 625 is connected to the correct power supply.

5) AIR PRESSURE LIGHT - when the machine is correctly connected to an air supply and the regulator adjusted so the air pressure Gauge reads 60 to 75 psi, the green air pressure light will be illuminated. If the air pressure is insufficient, the green air pressure light will not be illuminated and the red trouble alert light will light up.

6) THERMO SWITCH LIGHT - if the duty cycle of the machine is exceeded (50% at 50 amps) the yellow thermo switch light will be illuminated. When the duty cycle light is on and the trigger switch on the cutting torch is depressed, your Micro Cut 625 will flow air but will not arc. When the duty cycle has been exceeded, leave the machine on so the cooling fan will continue to run, cooling the machine. When the machine has cooled down, the yellow light will go out and you can cut again.

7) TROUBLE LIGHT - this lamp will illuminate red when the machine is first turned on. Pressing the reset button will turn the red trouble light off. If the red trouble light remains on, either the plasma torch is not installed correctly on the machine or the consumable parts are not installed correctly on the plasma torch.

8) CUTTING POWER ADJUSTMENT - the cutting power adjustment controls the cutting amperage of your Micro Cut 625. It is infinitely variable from 10 to 50 amps. At the lower power settings, the machine will throw fewer sparks - but will also cut slower. The maximum cutting power will give you the maximum cutting speed through all materials.

9) PLASMA TORCH CONNECTION - the central adapter block is where the plasma torch connects to the front of your Micro Cut 625. Your machine will not operate without the torch properly connected. (see page 5 - plasma torch connection)

10) GROUND CABLE CONNECTION - this is where the ground cable connects to the front of your Micro Cut 625. Align the tab on the ground clamp with the notch in the connection. Insert the ground clamp and twist to lock in place. Be sure to connect the ground to the workpiece properly. (see page 5 - ground cable connection)

Operation

1. Be sure your Micro Cut 625 is connected to a clean, dry source of compressed air with a line pressure of at least 80 but not more than 140 psi.
2. Connect your Micro Cut 625 to a 220 volt power supply. (see electrical connection). Turn the On-Off switch on the back of the unit on. The green 220 V light and the green air pressure light will turn on. The fan will begin to run. The red trouble light will be on. Press the reset switch to turn the trouble light off.
3. Refer to the safety suggestions to be sure the operator has the correct eye protection, gloves, clothing, and that all of the safety precautions have been followed.
4. Connect the ground clamp to a clean surface on the vehicle or the work piece that is as close as possible to the area to be cut. Make sure the ground clamp comes in contact with clean, bare metal. If you are working on an automobile, make sure the ignition is off, and disconnect the battery. Many auto manufacturers recommend the removal of on-board computers - if you have any questions, check with the vehicle manufacturer. Be sure not to connect the ground clamp to the piece which is being cut off.
5. Place the cutting torch on the edge of the material to be cut. Depress the trigger on the cutting torch. The air will start to flow, and the arc will start. Hold the plasma torch perpendicular to the work and slowly move the torch into the area to be cut. When you release the trigger, the arc will stop, but air will continue to flow for about 10 seconds.

The highest cutting efficiency is achieved by keeping the plasma cutting tip perpendicular and in contact with the work surface putting very little down force on the plasma torch. If you move too fast, sparks will shoot up and you will not cut all the way through the work. If you are cutting correctly all the plasma sparks will go beneath the panel you are cutting.

Familiarize yourself with the consumable parts and their correct assembly onto the torch head (see page 14).

WARNING: Never disassemble the cutting torch unless the machine has been disconnected from its power supply.

Maintenance and Service

Always disconnect the machine from the main power source before performing any maintenance or service work.

1. Remove machine housing frequently and blow residual material from inside of machine.
2. Check nozzle and electrode often for excessive wear due to cutting.
3. Clean exposed torch consumables often. This will maintain their life.
4. Check nozzle and electrode often for proper installation.
5. Frequently check the air supply quality. This is the single most important factor in the maintenance of the plasma system.
6. If any damage to the machine or torch is noticed, contact your local distributor or HTP America, Inc. directly at 1-800-USA-WELD.

IF ANY SERVICE OTHER THAN THE AFOREMENTIONED IS NECESSARY, IT SHOULD BE PERFORMED BY AUTHORIZED PERSONNEL ONLY.

Cutting Tips

1. When making long, straight cuts, it may be easier to use a metal straight edge as a guide. Simply clamp it to the workpiece to be cut. HTP America, Inc. also manufactures a complete Circle-Cutting and Straight-Line Traversing Assembly for frequent cutting of circles and lines.
2. When cutting heavier gauge material (up to the machine capability) it is recommended to initiate the pilot arc off the edge of the material and dragging the pilot arc to the workpiece.
3. When making rust repairs, it is possible to place the new metal over the rusted area and then cut your patch panel at the same time you cut the rust. This process works similarly when splicing a quarter panel.
4. Please note that sparks from cutting arcs can damage painted surfaces. The sparks will also pit glass. We recommend the use of a welding blanket such as HTP's #12060 or #12061 spark guard to protect these surfaces.
5. The best cutting speed is achieved when the plasma arc penetrates the workpiece at an angle of 5-10 degrees. The cutting speed is dependent on material thickness and composition as well as operator proficiency.
6. Never turn the machine off immediately after cutting. Always allow the post air flow circuitry to run its complete cycle to ensure proper cooling of the torch head.
7. It is highly recommended that piercing requirements be kept to a maximum of 75% of rated cutting thickness. This will greatly enhance the plasma torch's consumable life. When piercing thick pieces of metal, it is best to hold the cutting torch at a 45 degree angle to the work until the plasma arc has pierced the material. Holding the torch perpendicular to the work will result in sparks and slag firing back up into the plasma torch, greatly reducing consumable life.

Parts Breakdown - Micro Cut 625

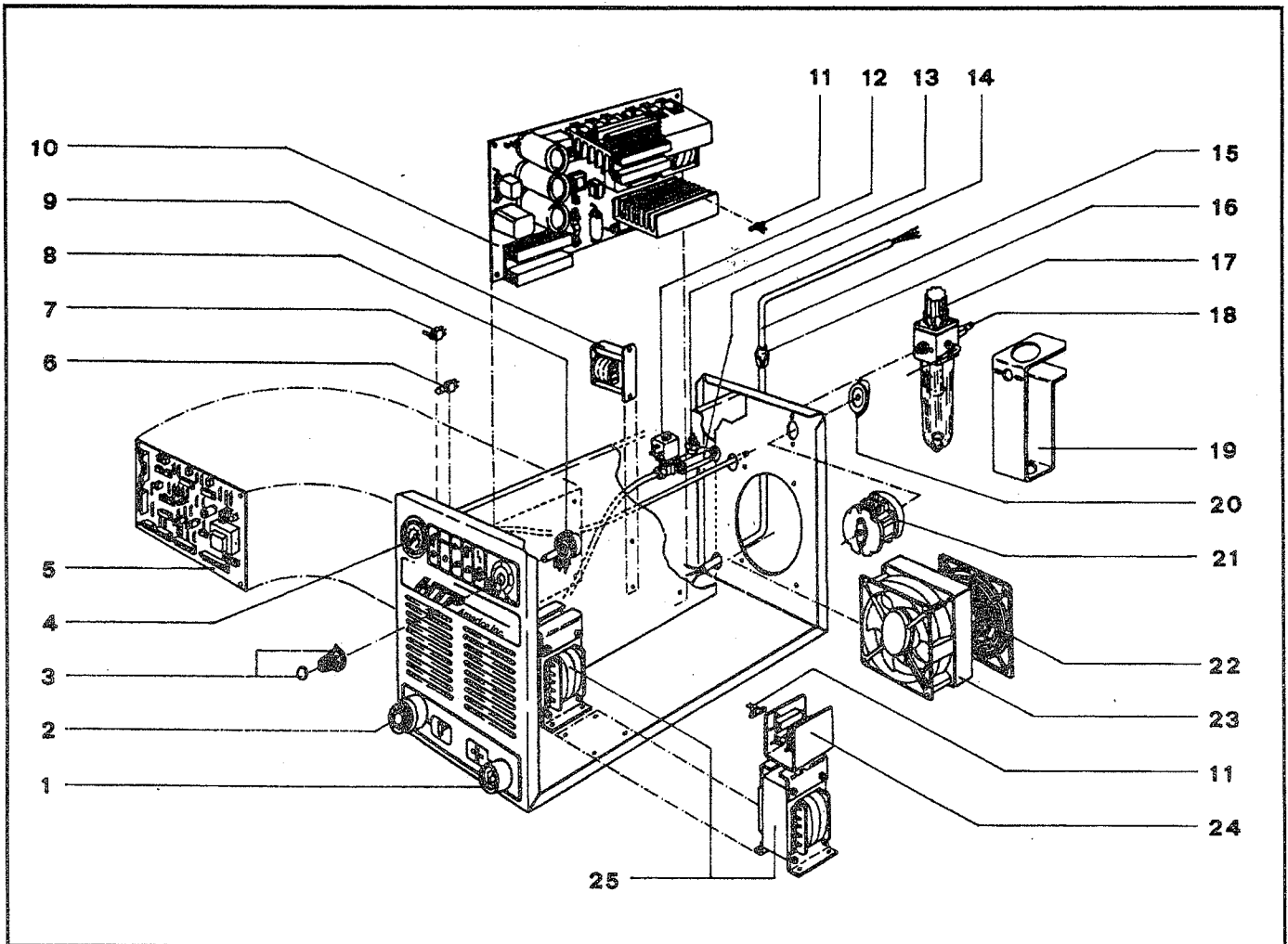
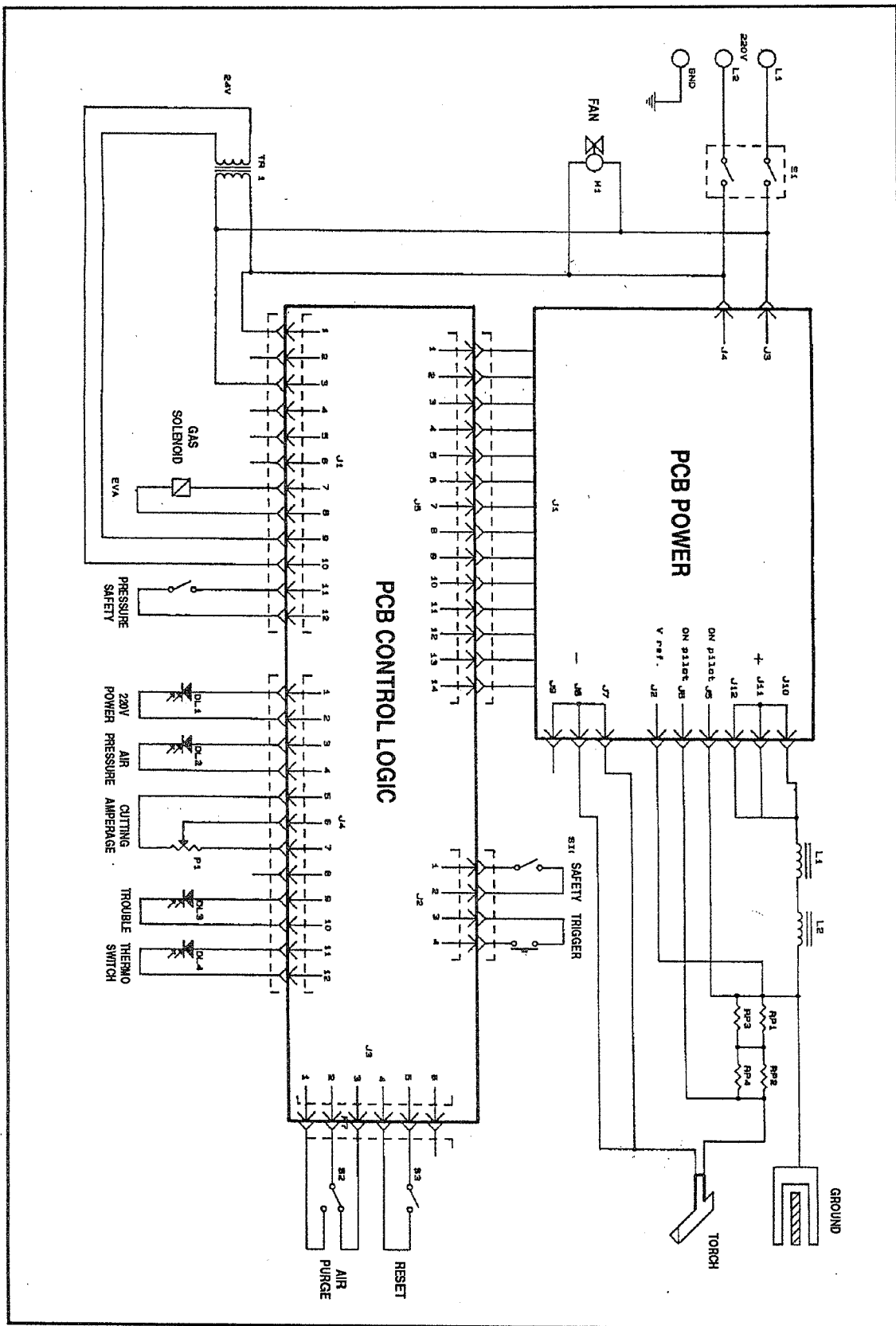
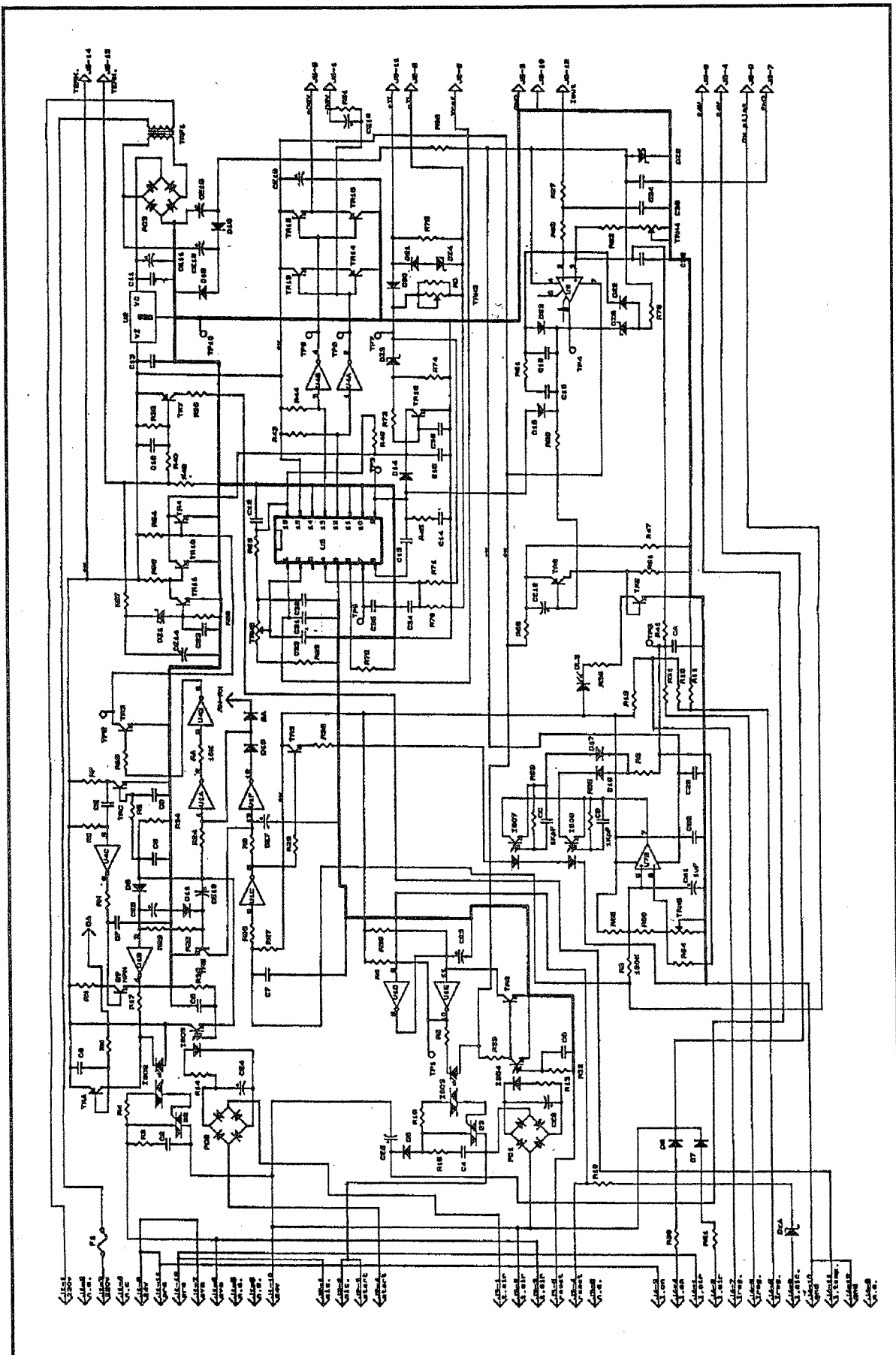

Figure #	Part #	Description	Figure #	Part #	Description
1	64280	Female Ground Receptacle	13	64032	Pressure Safety Switch
2	64208	Adapter Block - Plasma Torch	14	63168	Air Manifold
3	66119	Knob	15	20137	Input Power Cord
4	63053	Pressure Gauge	16	66062	Strain Relief
5	61855	PCB - Control Side	17	63052	Filter/Regulator
6	64038	Reset Switch	19	62292	Regulator Housing
7	64167	Air Purge Switch	20	66231	Knob - On-Off Switch
8	64201	Potentiometer	21	64650	On-Off Switch
9	65999	Control Transformer	22	66098	Fan Guard
10	61854	PCB - Plasma Power	23	64182	Cooling Fan
11	64215	Thermoswitch	24	61032	Arc Initiator
12	64005	Air Solenoid Valve	25	61303	Choke Coil

Wiring Diagram - Micro Cut 625



PCB - Control Logic



PGB - Power

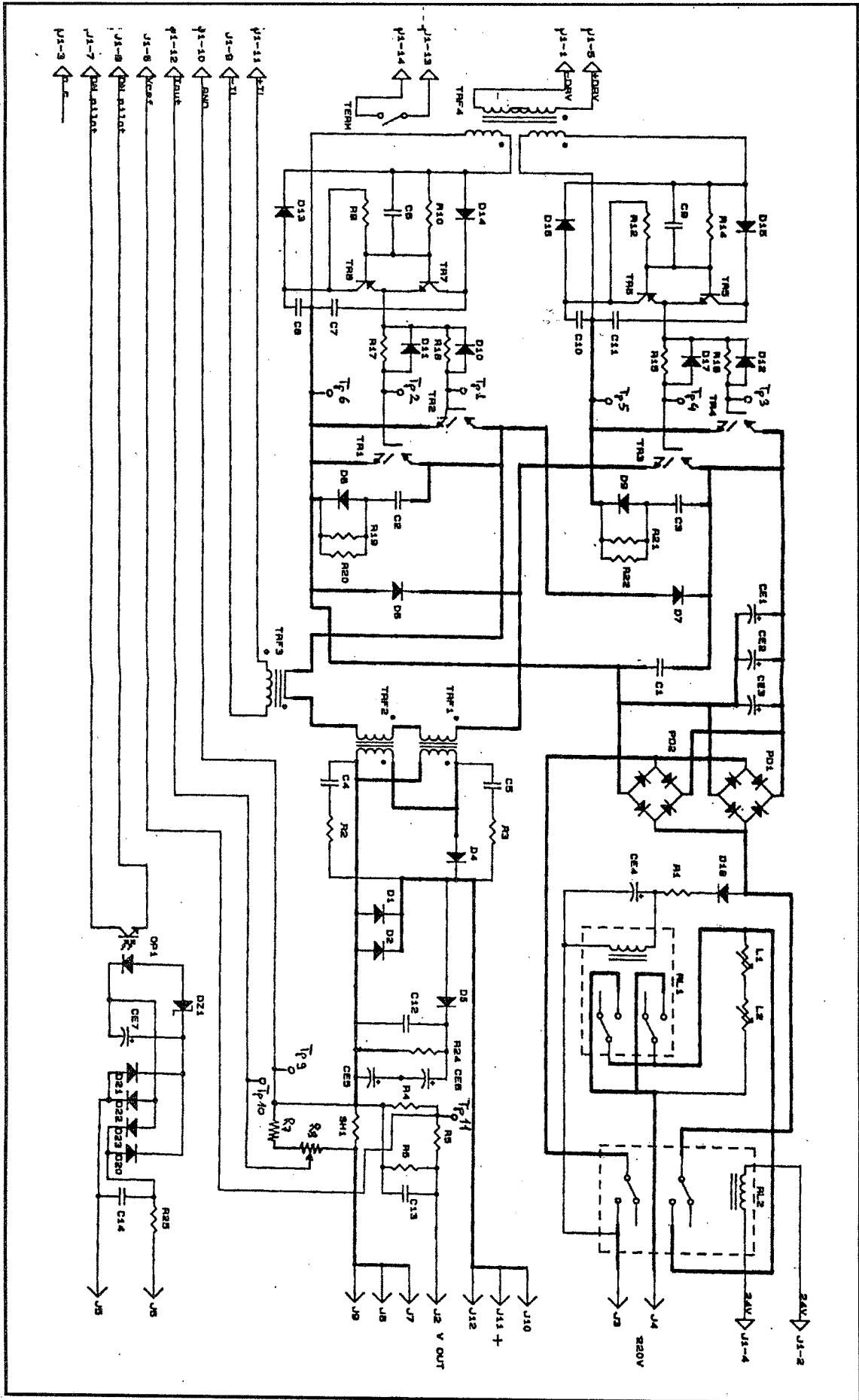

TROUBLE SHOOTING GUIDE

PROBLEM	POSSIBLE CAUSE	SOLUTION
Led green (power does not light up although ON-OFF switch is in position 1).	1) No power 220V 50/60Hz at PAC15 inlet. 2) Line fuse is burnt.	1) Check power line, if necessary replace fuse.
Power set is on, but led green (COMPRESSED AIR) does not light up.	1) Air pressure too low.	1) Check if air filter is blocked. 2) Increase air pressure.
Power set is on, but yellow led (TEMP. PROTECTION) lights up.	1) Power set is still over heated. Leave fan on. 2) Faulty temperature sensor.	1) Turn on power set and wait a few minutes before working. 2) Contact authorized service rep.
Power set is on, led red remains on.	1) Power set fails; safety interlock.	1) Depress green reset switch.
Power set is on, led remains on even if it is reset.	1) Safety interlock.	1) Check air pressure. 2) Check if torch cup is tightened firmly.
Thermal protection relay on line 220V 50/60Hz trips during cutting operation.	1) Available input power too low to keep up with output demand. 2) Another machine is operating on the same power line.	1) Reduce cutting current with the front control panel, or reduce cutting period. 1.1) Shorten power line cable, or increase cable cross section.
Pilot arc does not appear, or disappears during cutting.	1) Oxide is present on worn torch parts. 2) Parts worn out. 3) Power set is over heated. 4) Insufficient air pressure. 5) Low voltage on input line.	1) Replace worn parts, or clean them with a metal brush. 2) Check torch, if necessary replace worn parts. 3) Look at the led yellow (TEMP. PROTECTION) on front panel: if on, wait for powerset to cool. 4) Look at the led green (AIR PRESSURE) on front panel; if off, increase air pressure. 4.1) Check if air filter is blocked, if necessary replace it. 5) Check input power line. If you use an extension be sure the cable cross section is adequate.
Pilot arc appears but current is insufficient for cutting.	1) Bad connection of ground clamp. 2) Bad connection of positive machine outlet.	1) Check if ground clamp has good contact with workpiece. 2) Check connection to output positive socket, from the inside too.
Cut is not perpendicular	1) Electrode or nozzle worn out.	1) Replace electrode and nozzle.

COMMON CUTTING PROBLEMS

PROBLEM	SOLUTION
1) Insufficient penetration.	1) - Cutting speed too high; Cutting current too low; Poor ground clamp connection.
2) Cutting arc extinguishes.	2) - Distance from workpiece too high.
3) Heavy dross formation.	3) - Inadequate air pressure; Tip orifice eroded (too large).
4) Intermittent pilot arc.	4) - Air pressure too high (keep to 5 bar). - Air supply inefficient (keep to 5 bar). - Air supply dirty (use correct filter regulator). - Air supply wet (use correct filter with drain set). - Air supply oily (use correct filter with oil removing set). - Air supply