

Invertig 221/221DV AC/DC Owner's Manual



Index

Manufacturer's Warranty	3
Safety Suggestions	4
Electrical Connection	4
Front Panel Connections	5
Rear Panel Connections & Controls	5
Front Panel Controls	
Welding Parameter Section	6-10
Welding Mode Section	11-15
Tungsten Electrodes	16
General Welding Parameters & Quick Set Up	17
Filler Rod	17
TIG Torch Consumables	19-23
Invertig 221 AC/DC (Single Voltage) Parts Diagram & List	14
Invertig 221 AC/DC (Single Voltage) Wiring Diagram	25
Invertig 221DV AC/DC (Dual Voltage) Parts Diagram & List	26
Invertig 221DV AC/DC (Dual Voltage) Wiring Diagram	27

Manufacturer's Warranty

It is expressly agreed that there are no warranties, expressed or implied, made by either the Salesman, Dealer, or HTP America, Inc. on products or parts furnished hereunder, except the Manufacturer's Warranty against defective materials or workmanship as follows:

HTP America, Inc. warrants each new welding machine to be free from defects in material and workmanship under normal use and service for three years after delivery to the original purchaser. HTP America, Inc. will repair and replace, at its factory, any part or parts thereof, products to be returned to HTP America, Inc. with transportation charges prepaid and which its examination shall disclose to its satisfaction to have been thus defective. This warranty being expressly in lieu of all other warranties, expressed or implied, and all other obligations or liabilities on its part and it neither assumes nor authorizes any other person to assume for it any other liability in connection with the sale of its machines.

This warranty shall not apply to any welding machine which has been repaired or altered by unauthorized service departments in any way so as in the judgment of HTP America, Inc. to affect its stability and reliability, nor which has been subjected to misuse, negligence or accident.

HTP America, Inc. shall not be liable in any event, unless HTP America, Inc. receives notice of alleged breach of warranty within not more than 30 days after the discovery, actual or construction alleged breach of warranty specifying the claimed defect.

HTP America, Inc. has reserved the right to make change in design or add any improvements to its products at any time without incurring any obligation to install same on equipment.

This warranty is void unless warranty card is sent to HTP America, Inc. within 15 days from date of purchase.

Note:

Exclusions to Warranty:

1. The TIG Welding Torch is warranted for a period of ninety (90) Days against defects in material and workmanship.
2. The tungsten, collet, collet body, ceramic nozzles are consumable items, WHICH CARRY NO WARRANTY.
3. This warranty is to the original purchaser only. The warranty can be transferred to another owner, with HTP's approval, for a warranty transfer fee. HTP America, Inc. must be notified within fourteen (14) days of the sale and must be provided with the contact information of the original owner, the contact information of the new owner, and the serial number of the machine.

Safety Suggestions

Electric arc welding produces ultra-violet rays, which are harmful to skin and eyes. Ultra-violet radiation can penetrate lightweight clothing, reflect from light colored surfaces, and burn the skin and eyes. Wear flameproof welding gloves which are not oily or greasy. The oil or grease on the gloves may ignite. Wear a heavy, pocket-less, long sleeve shirt, cuffless trousers, and high-topped work shoes. Wear a full-face welding helmet with a number eight or darker lens and a cap. These precautions will protect eyes, hair, face, and skin from arc rays and hot material.

- To avoid fire, do not weld on wood, plastic tile, or carpeted floors. Concrete or masonry floors are safest.
- Do not weld on drums, barrels, tanks or other containers until they have been cleared as described in AWS Standard A6.01.
- Provide adequate ventilation in the welding area at all times. Do not weld on galvanized zinc, cadmium or lead beryllium materials unless you are POSITIVE sufficient ventilation is provided. These materials produce toxic fumes.
- Do not weld in areas close to degreasing or spraying operations. Chlorinated hydrocarbon vapors may react with the ultra-violet rays and form highly toxic phosgene gas.
- If you develop momentary eye, nose or throat irritation during welding, stop welding immediately. This is an indication that ventilation is not adequate. Do not continue to weld until ventilation is improved.
- Exposed, electrically hot conductors or other bare metal in the welding circuit, or ungrounded electrically hot equipment can fatally shock a person whose body becomes a conductor. Do not stand, sit, lie, lean on or touch a wet surface when welding.
- Frequently inspect cables for wear, cracks, and damage. Replace those with excessively worn insulation to avoid a possible lethal shock from bared cable.

For more information, refer to the following standards and comply as applicable.

1. ANSI Standard Z49.1 SAFETY IN WELDING AND CUTTING, obtainable from the American Welding Society, 2051 NW 7th St., Miami, FL 33125.
2. ANSI Standard Z87.1 SAFE PRACTICE FOR OCCUPATION AND EDUCATIONAL EYE AND FACE PROTECTION, obtainable from American National Standards Institute, 1430 Broadway, New York, NY 10018.
3. America Welding Society Standard A6.0 WELDING AND CUTTING CONTAINERS WHICH HAVE HELD COMBUSTIBLES, obtainable same as item 1.
4. NFPA STANDARD 51. OXYGEN-FUEL GAS SYSTEMS FOR WELDING AND CUTTING, obtainable from the National Fire Protection Assoc., 470 Atlantic Avenue, Boston, MA 02210.
5. NFPA Standard 51B. CUTTING AND WELDING PROCESSES, obtainable same as item 4.
6. CGA PAMPHLET P-1. SAFE HANDLING OF COMPRESSED GASES IN CYLINDERS, obtainable from the Compressed Gas Association, 500 Fifth Avenue, New York, NY 10036.
7. OSHA Standard 29 CFR, Part 1910, Subpart Q WELDING, CUTTING AND BRAZING.

Electrical Connection

Your Invertig 221 AC/DC operates on single-phase, 230 volt power (+/- 15%). The machine is shipped with a plug. **The input power cord has 3 wires. The green wire is ground, and the black and white wires are the hot leads.**

The machine draws 36 amps out of the wall when operating at a welding output of 220 amps in the TIG mode and 44 amps when welding at an output of 200 amps in the stick mode.

The Invertig 221 DV has the ability to operate on either 110 or 230 volts. All you need to do is change the plug. When wiring the machine for 110 volts, you typically use an adapter cable fitted with a 110 volt plug on one end and a 220 volt female receptacle, one that matches the 220 volt plug on your machine's power cord, on the other.

On 230 volts, the machine draws 26 amps out of the wall when operating at a welding output of 220 amps in the TIG mode and 32 amps when welding at an output of 200 amps in the stick mode.

On 110 volts, the maximum output is 155 amps. The output must be limited to 130 amps in the TIG welding mode to run on a 30 amp breaker, 85 amps to run on a 20 amp breaker, and 67 amps to run on a 15 amp breaker. In the stick mode, the output must be limited to 100 amps to run on a 30 amp breaker, 65 amps to run on a 20 amp breaker, and 50 amps to run on a 15 amp breaker.

All electrical connections should be performed by a qualified electrician in accordance with the National Electrical Code and local codes and ordinances.

FRONT PANEL CONNECTIONS



Figure 1

1 2 3 4

1. Negative Output Receptacle

When TIG welding, this is where the TIG Torch connects to your Invertig 221 Welder. That's right, we said the TIG Torch. This is called straight polarity, with the torch negative and the work positive. When using your Invertig Welder to TIG weld, all work will be done in straight polarity.

When Stick Welding Direct Current Electrode Negative (DCEN), the optional electrode holder will be plugged into the negative output receptacle. When Stick Welding Direct Current Electrode Positive (DCEP), the ground cable will be plugged into the negative output receptacle

To install a cable into the negative output receptacle, insert the male end of the cable into the negative output receptacle and twist clockwise until snug.

2. Gas Output Connection

This is where you connect the gas fitting from the TIG Torch. The gas output is controlled by the solenoid valve, which is mounted inside the welder.

3.7- Pin Connection

The 7-pin connection is where your remote amperage control would connect to your 221. This is also where you would connect a momentary contact switch. Insert the connection into the machine and twist the lock ring clockwise until snug.

I have found it is easiest to connect the remote first, the gas second, and the positive and negative receptacles last.

4. Positive Output Receptacle

When TIG welding, this is where the ground cable connects to the front of the TIG Adapter. That's right, we said the ground cable. This is called straight polarity, with the torch negative and the work positive.

When Stick Welding Direct Current Electrode Negative (DCEN), the ground cable will be plugged into the positive output receptacle. When Stick Welding Direct Current Electrode Positive (DCEP), the electrode holder will be plugged into the positive output receptacle.

To install a cable into the positive output receptacle, insert the male end of the cable into the positive output receptacle and twist clockwise until snug.

REAR PANEL CONTROLS AND CONNECTIONS

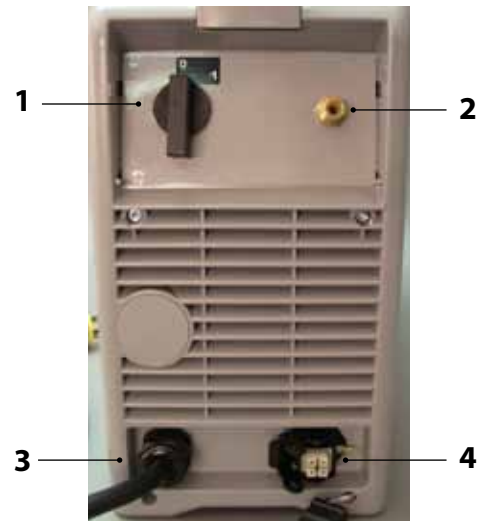

Figure 2

1. On-Off Switch

This switch controls the input power to your Invertig Welder. 0 is off and 1 is on.

2. Gas Inlet Connection

Connect the female end of your gas hose to the inlet gas connection and the male end of your gas hose to your flowmeter.

Shield Gas

TIG welding requires a shield gas of 100% Argon. A shield gas is used to keep the surrounding atmosphere from coming in contact with the molten weld puddle. The correct flow rate is enough gas to shield the molten weld puddle and protect the tungsten electrode. Any greater flow rate is a waste of shield gas. Usually, the flow rate will be set anywhere between 15 and 30 cubic feet per hour (CFH).

Use a gas regulator such as HTP Part #12020 which is compatible with Argon cylinders and has a barbed fitting for the delivery hose.

Argon/helium mixtures can be used to increase penetration. Argon/helium mixes with high (more than 50%) helium content will give you difficulties starting the arc, as well as arc stability issues. As far as added headed into the weld puddle, there are no real advantages to running mixtures with more than 50% helium in AC mode. If you will be welding thick aluminum castings such as an aluminum cylinder head, ultra high purity helium can be used. If you are welding thick aluminum sections like cylinder heads and engine blocks, and you do not want to preheat the part, you can weld these items in DC using ultra high purity helium, to achieve maximum penetration without pre-heating. Since there is no AC cleaning cycle, it is important proper cleaning practices are followed.

3. Input Power Cord – this is where the input power cord passes through the rear of the cabinet.

4. 220V & 110V/220V Water-Cooler Connection – This is the electrical connection where a 220V or 110 V/220V water-cooler will connect to your Invertig 221/Invertig 221DV. If you have an Invertig 221DV, the water-cooler will operate with the Invertig 221DV connected to either 110V or 220V power. The water-cooler, like the Invertig 221 DV, auto senses the input power voltage.

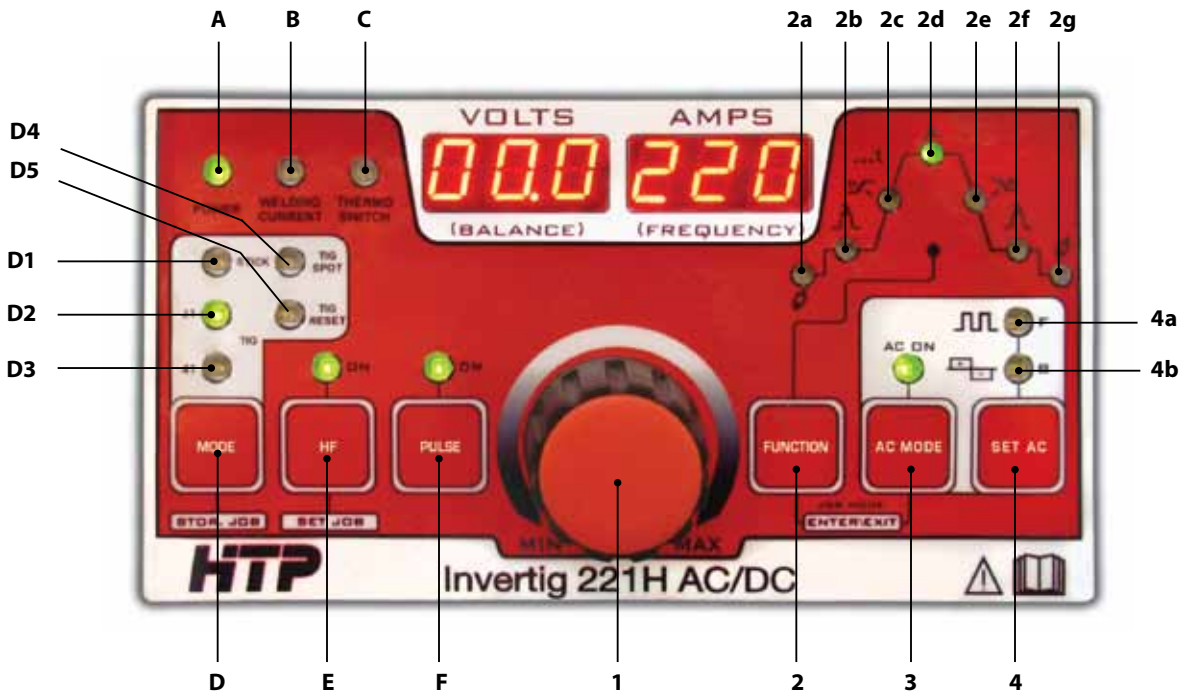

FRONT PANEL CONTROLS

The front panel controls will be split into 2 sections – the welding mode section and the welding parameter section. The welding mode section covers the different welding modes – such as Stick Welding, TIG 2T welding and so on. The welding parameter section covers all the different adjustments such as pre-gas, post gas, slope down and so on.

Welding Parameter Section

1) Encoder – All of the welding parameters are adjusted using the encoder. Turning the encoder clockwise increases the setting and counter clockwise decreases it. The encoder adjusts all of the functions of your 221.

2) Function Button – the function button allows you to select between the 7 different welding parameters. The default setting is A (2D) amperage. When the green light is illuminated under the “A” setting (2D) as shown in Photo 1, you can adjust the amperage using the Encoder (1). The amperage can be adjusted between 4 and 220 amps in any of the TIG welding modes and between 4 and 200 amps in the stick welding mode.

2A – Pre Gas – Depressing the function button until the “pre gas” light (2A) is illuminated will allow you to adjust the pre-gas setting. As shown in Fig 4, the pre gas light (2A) is illuminated and the amps display will flash “PrG”. While the display is flashing, the pre gas time will be displayed in the “AMPS” digital display in seconds. Use the encoder to adjust the pre-gas from .1 sec to 2.0 sec in .1 sec increments while the display is flashing.

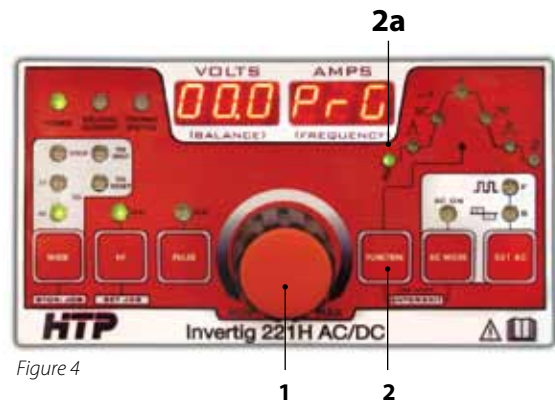

Figure 4

Pre-gas is the amount of time the gas flows before the arc has been ignited. This ensures there will be no weld contamination from air, since the weld area will be purged with shielding gas prior to welding. A good starting value is .4 sec.

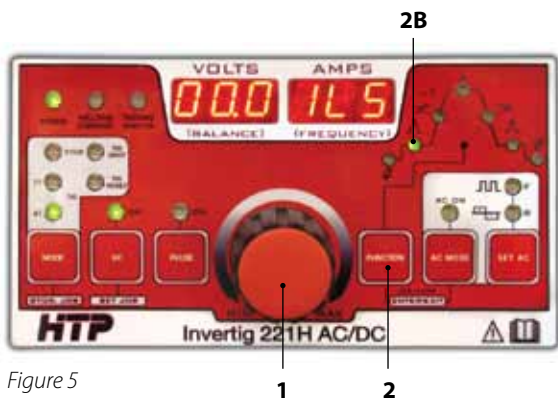

Figure 5

2B - Starting Current - Depressing the function button (2) until the “starting current” light (2B) is illuminated will allow you to adjust the starting current in %. As shown in Fig 5, the starting current light (2B) is illuminated and the amps display will flash “1LS”. While the display is flashing, the starting current will be displayed in the “AMPS” digital display in percent of the peak welding current. Use the encoder (1) to adjust the starting current from 10% to 90% in 1% increments while the display is flashing.

2C - Slope Up - Depressing the function button (2) until the “slope up” light (2C) is illuminated will allow you to adjust the slope up setting. As shown in Fig 6, the slope up light (2C) is illuminated and the amps display will flash “SLu” for slope up. While the display is flashing, the slope up time will be displayed in the “AMPS” digital display in seconds. Use the encoder to adjust the slope up from .1 sec to 2.0 sec in .1 sec increments while the display is flashing.

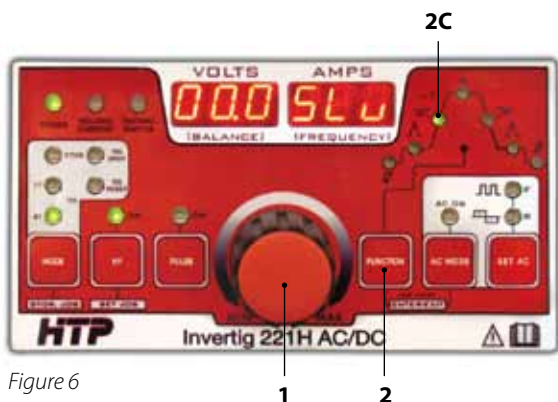

Figure 6

Slope up is the amount of time it takes the welder to reach the peak current from the starting current.

2D - Peak Current (AMPS) - When the green light is illuminated under the “A” setting (2D) as shown in Fig 7, you can adjust the amperage using the Encoder (1). The amperage can be adjusted between 4 and 220 amps in any of the TIG welding modes and between 4 and 200 amps in the stick welding mode. This is the default setting for the welding function button.

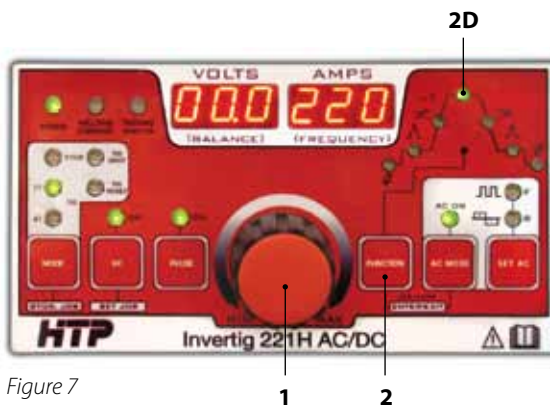

Figure 7

2E - Slope Down - Depressing the function button (2) until the “slope down” light (2E) is illuminated will allow you to adjust the slope down setting. As shown in Fig 8, the slope down light (2E) is illuminated and the amps display will flash “SLd”. While the display is flashing, the slope down time will be displayed in the “AMPS” digital display in seconds. Use the encoder to adjust the slope down from .1 sec to 2.0 sec in .1 sec increments while the display is flashing.



Figure 8

Slope down is the amount of time it takes the welder to reach the final current from the peak current. This setting is used to allow the molten weld puddle to solidify gradually to help prevent a crater from forming.

2F - Final Current - Depressing the function button (2) until the “final current” light (2F) is illuminated will allow you to adjust the final current in %. As shown in Fig 9, the final current light (2F) is illuminated and the amps display will flash “1Lo”. While the display is flashing, the final current will be displayed in the “AMPS” digital display in percent of the peak welding current. Use the encoder to adjust the final current from 10% to 90% in 1% increments while the display is flashing.



Figure 9

2G – Post Gas – Depressing the function button (2) until the “post gas” light (2G) is illuminated will allow you to adjust the post-gas flow. As shown in Fig 10, the post gas light (2G) is illuminated and the amps display will flash “PrG”. While the display is flashing, the post gas time will be displayed in the “AMPS” digital display in seconds. Use the encoder to adjust the post gas from .1 sec to 30.0 sec in .1 sec increments while the display is flashing.



Figure 10

Post gas is the amount of time the gas flows after the arc has been extinguished. This ensures there will be no weld contamination from the atmosphere while the weld puddle cools, since the weld area will be purged with shielding gas after welding. A good starting value is 6 sec. The larger the tungsten diameter and the higher the amperage, the longer the post gas flow needs to be.

3) AC Welding Mode - Depressing the AC welding mode button (3) will illuminate the green “AC ON” light indicating your Invertig 221 is in the AC welding mode as shown in Fig 11. If the AC ON light is flashing, it indicates you have independent AC amperage adjustment engaged.



Figure 11

To turn the AC Welding Mode off, depress the AC Welding Mode button for at least 3 seconds until the green AC welding mode light goes out.

For welding aluminum and magnesium, you want the “AC ON”. For steel, stainless steel, 4130 tubing, and all other materials, you want the AC welding mode off.

4) Set AC

The “Set AC” button (4) allows you to adjust the AC welding parameters when the machine is in the AC welding mode. The parameters which can be adjusted are AC Frequency, AC Balance, Electrode Negative welding amperage and Electrode Positive welding amperage.

AC Frequency



Figure 12

Depress the “SET AC” button (4) once. As shown in Fig 12, the frequency light (4A) will flash and the amps display will flash “F.AC”. While the display is flashing, the frequency will be displayed in the “AMPS” digital display in Hz (Cycles per second). Use the encoder (1) to adjust the AC frequency from 20 Hz to 200 Hz in 1 Hz increments while the display is flashing.

Higher AC frequencies focus the arc cone more to a point and give you greater arc control with less arc wandering. Lower AC frequencies increase the overall heat input in the material to weld thicker sections of aluminum.

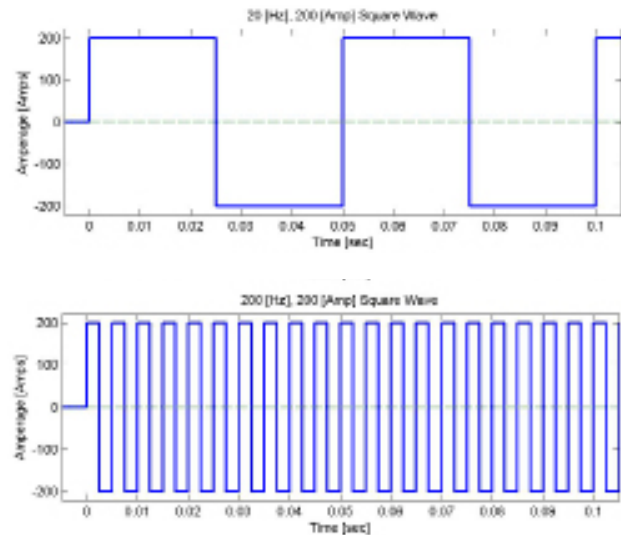

Chart 12a

In chart 12A you can see the effect the AC Frequency has on the square wave. The 20 Hz wave is shown at the top. The AC wave changes from electrode positive to electrode negative 20 times a second. In the bottom you see a 200 Hz wave – The AC wave changes from electrode positive to electrode negative 200 times a second – 10 times faster than the 20 Hz wave. The higher AC frequency focuses the arc cone more to a point, allows you to maintain a point on the tungsten, a gives you greater arc control with less arc wandering. I try to picture this graph in my head when I change the AC frequency so I can understand how I am changing the wave and the arc characteristics.

AC Balance



Figure 12B

Depress the “SET AC” button (4) twice. The balance light (4B) will flash and the volts display will flash “b.AC”. While the display is flashing, the AC balance will be displayed in the “VOLTS” digital display in %. Use the encoder (1) to adjust the AC balance from 10% to 90% in 1 % increments while the display is flashing.

A higher AC balance percentage gives you more electrode negative, so you get more penetration, less cleaning, and your tungsten runs cooler. A lower AC balance gives you more electrode positive, which is more cleaning, less penetration, but your tungsten runs hotter.

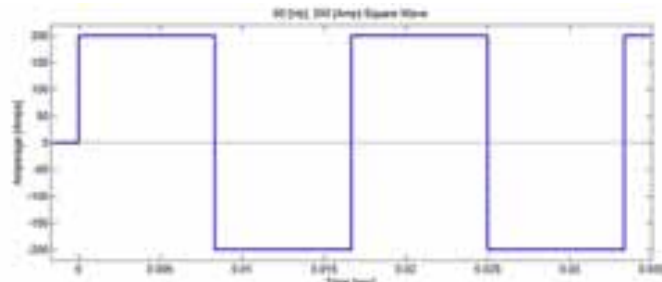

Chart 12c

Chart 12C shows 60 Hz AC wave with the AC balance set to 50%. This is called a balanced square wave. The amount of time the electrons flow from the torch to the work, and then from the work to the torch, is equal.

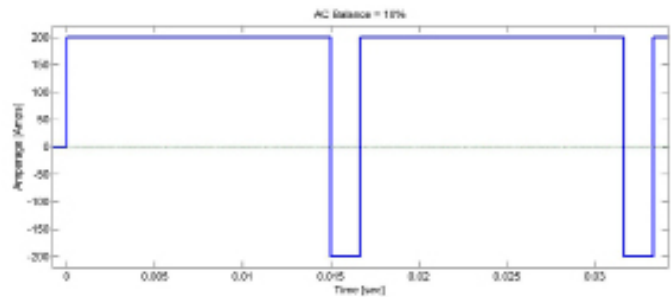

Chart 12d

If you remember from the front panel connections, the ground cable is in the positive output receptacle and the torch is in the negative. Chart 12D shows the AC balance set to 10%. For 10% of the time, the torch is negative and the electrons flow from the torch to the work piece. The flow of electrons from the torch to the work is the penetration cycle. The other 90% of the time, the torch becomes positive and the work becomes negative, and the electrons jump from the work to the tungsten. This flow of electrons from the work to the torch is the cleaning cycle. The electrons literally blow the impurities off the molten puddle. So when the AC Balance is set to 10% the machine is set for maximum cleaning. You have to remember with the balance set this low, you are putting an extreme amount of heat into your tungsten, and you will probably see a 1/8” tungsten melt at less than 50 amps. One application where you may want more cleaning (lower AC Balance) would be if you were welding on a dirty casting.

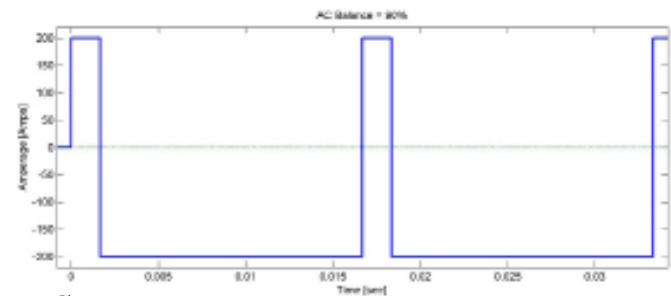

Chart 12e

Chart 12E shows the AC balance set to 90%. For 90% of the time, the torch is negative and the electrons flow from the torch to the work piece. The flow of electrons from the torch to the work is the penetration cycle. The other 10% of the time, the torch becomes positive and the work becomes negative, and the electrons jump from the work to the tungsten. This flow of electrons from the work to the torch is the cleaning cycle. So when the AC Balance is set to 90% the machine is set for maximum penetration. Higher AC balances put less heat into the torch, and more heat into the work. An application where you may want more penetration (higher AC Balance) would be if you were trying to weld a heavier section than you could normally weld with 220 amps – say something in the 3/8 to 1/2” range. Setting the balance to 90% may allow you to make this weld, depending on the application. It is important to note, that with less cleaning it is critical to clean the piece properly.

Electrode Negative AC Amperage Adjustment



Figure 13

Depress the "SET AC" button (4) once, release, then press again and hold. As shown in Fig 13, the balance light (4B) will rapidly flash and the amps display will flash "En-" and the machine will beep once. Release the "SET AC" button, and while the display is flashing, the electrode negative amperage will be displayed in the "AMPS" digital display in % of peak current. Use the encoder (1) to decrease the electrode negative amperage from 10% to 90% of the peak amperage in 1 % increments while the display is flashing.

Whenever the AC amperage has been independently adjusted, the "AC ON" light will flash. To exit independent AC amperage adjustment, hold the "SET AC" button in until the balance light goes out and the AC ON light glows continuously.

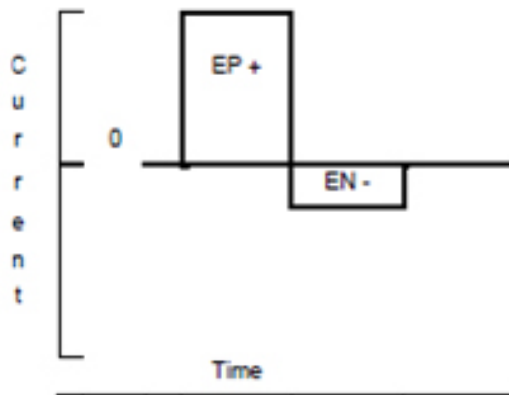

Chart 13A

Chart 13 A shows the effect of reducing the Electrode Negative Current on the square wave. You can see this is a balanced square wave (AC Balance = 50%) which means the time welding in electrode positive and electrode negative is the same. What we are changing is the amperage. By reducing the electrode negative amperage, we are putting less heat into the work piece, there will be less penetration, the bead will be wider, and there will be more cleaning. This will also put more heat into the tungsten, so the tungsten may need to be sharpened more frequently.

Electrode Positive AC Amperage Adjustment



Figure 14

Depress the "SET AC" button (4) once, release, then press again and hold. As shown in Fig 14, the balance light (4B) will rapidly flash and the amps display will flash "En-". Continue to hold the "SET AC" button, and a number will come in the display, and then the amps display will flash "EnP" and the unit will beep twice. Release the "SET AC" button, and while the display is flashing, the electrode positive amperage will be displayed in the "AMPS" digital display in % of peak current. Use the encoder (1) to reduce the electrode positive amperage from 10% to 90% in 1% increments while the display is flashing.

Whenever the AC amperage has been independently adjusted, the "AC ON" light will flash. To exit independent AC amperage adjustment, hold the "SET AC" button in until the balance light goes out and the AC ON light glows continuously.

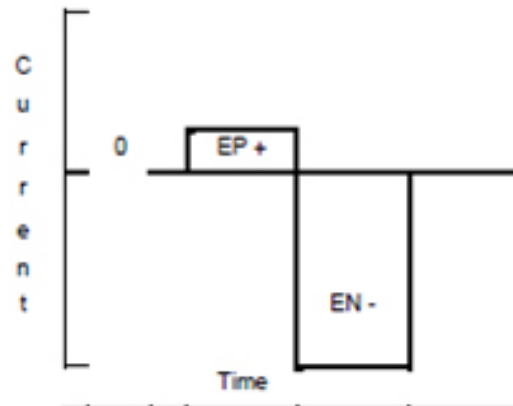

Chart 14A

Chart 14 A shows the effect of reducing the Electrode Positive Current on the square wave. You can see this is a balanced square wave (AC Balance = 50%) which means the time welding in electrode positive and electrode negative is the same. What we are changing is the amperage. By reducing the electrode positive amperage, we are putting less heat into the tungsten which will result in longer tungsten life. The arc cone will be narrower, there will be more penetration, the bead will be narrower, and there will very little visible cleaning at the weld toe.

Welding Mode Section



A) Power Indicator Lamp

This lamp is illuminated when the On-Off switch on the back of your Invertig 221 is turned to the 1 or "On" position, indicating the unit is correctly connected to 220 volt AC power.

B) Welding Current Indicator Lamp

When either the foot pedal or the trigger switch on the TIG torch is depressed, welding current will be applied to the welding torch and the Welding Current Indicator Lamp will be illuminated.

If your Invertig 221 AC/DC is in the stick-welding mode, the welding current indicator lamp will be illuminated all the time.

C) Thermoswitch Indicator Lamp

The thermoswitch indicator lamp will light up when the duty cycle of your Invertig 221 AC/DC has been exceeded. When this lamp is illuminated, the machine will no longer weld because the machine has overheated. Leave the machine plugged in and turned on so the cooling fans can cool the unit down. Allow the machine to cool for 15 to 30 minutes, the thermoswitch should reset automatically and your Invertig will be ready to weld.

D) Welding Mode Switch

The welding mode push button allows you to select the welding mode of your Invertig 221 AC/DC.

D1) Stick Welding Mode

Depressing the welding mode button (D) until the "stick" light (D1) is illuminated will activate the "stick welding mode". This mode is used for SMAW (stick electrode or arc) welding. As shown in Fig 16, the stick light (D1) is illuminated and the amps display will flash "Arc". When the display stops flashing, the welding current will be displayed in the "AMPS" digital display, and the welding voltage will be displayed in the "VOLTS" digital display.

The only parameter you can adjust is the amperage. Hot start and arc force are not adjustable. The machine will run all types of electrodes including 6010.



Figure 16

If you do not plan to use a remote control (hand or foot) for amperage adjustment while stick welding, remove the remote control. If you do not remove the remote control, the machine reverts to the start-up amperage (generally 4 amps) when you strike an arc, whether or not you manually set the amperage at the machine.

You can stick weld in both AC and DC. When stick welding in AC, all AC functions are adjustable – AC Frequency, AC Balance and independent AC amperage adjustment. The pulse function is also fully functional in the stick weld mode from 0.4Hz to 5Hz.

The electrode will always be hot and the gas solenoid will not operate. The green "Welding Current" lamp will be illuminated indicating the welding current is on.

V.R.D. (Voltage Reduction Device) is a system which reduces the no-load voltage to a lower and safer voltage (normally less than 18 volts). Used as an additional aid for operator safety and for when safety procedures at work require protection. The V.R.D. function not only makes the welding machine safer, but also makes the stick welding rods harder, or even very hard in some cases, to light. To activate the V.R.D., hold down the MODE button for approximately 5 seconds, and then release the button. The Stick welding mode LED flashes indicating the V.R.D. is activated. To deactivate the V.R.D., hold down the MODE button for approximately 5 seconds, and then release the button. The Stick welding mode LED stops flashing and illuminates solidly, indicating the V.R.D. is deactivated.

D2) TIG 2T Mode – From the Stick Mode, depressing the welding mode button (D) once will put you in the “2T” Mode. This mode will be used when welding with a remote amperage control. As shown in Figure 17, the 2T light (D2) is illuminated and the amps display Figure “t.2”. When the display stops flashing, the peak welding current will be displayed in the “AMPS” digital display, and the welding voltage will be displayed in the “VOLTS” digital display (00.0 unless you are welding).

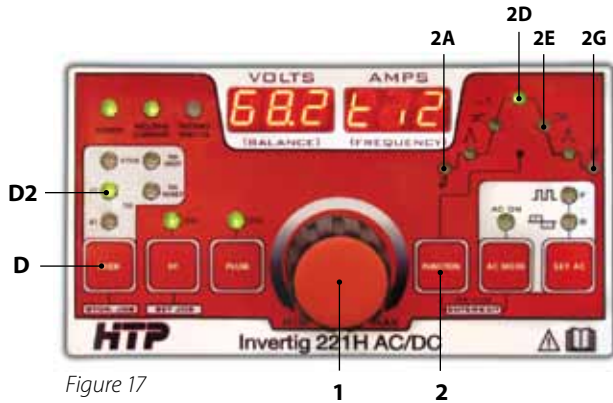

Figure 17

With the torch trigger or foot pedal depressed, your Invertig 221 will start the arc. When the trigger or foot pedal is released, the unit will stop. Select this welding mode for operation with the foot pedal or the torch mounted amperage control. This will generally be the most common mode of operation.

Welding parameters which can be adjusted using the encoder in the 2T mode are pre-gas (2A), slope down (2E), and post gas(2G).

D3) TIG 4T mode – From the 2T Mode, depressing the welding mode (D) button once will put you in the “4T” Mode (D3). This is like a lock on trigger on a drill or grinder. This mode is generally used with a TIG torch which has a trigger to start and stop the arc. It is not used with a foot pedal or a torch mounted amperage control.

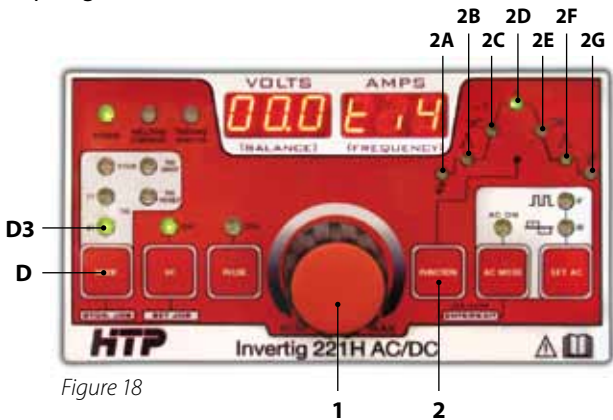

Figure 18

As shown in Fig 18, the 4T light (D3) is illuminated and the amps display will flash “t.4”. When the display stops flashing, the peak welding current will be displayed in the “AMPS” digital display, and the welding voltage will be displayed in the “VOLTS” digital display (00.0 unless you are welding).

When you depress the trigger on the torch, your Invertig 221 provides pre-gas flow for as long as the trigger is depressed. When the trigger is released, it will slope up to the welding amperage that has been selected. When the trigger is depressed again, the welding current will slope down to the final current. As long as the trigger is depressed, your Invertig 221 will continue to weld at the final current which has been selected. When the trigger is released, the arc will extinguish, and the post flow will start.

Welding parameters which can be adjusted using the encoder are slope down (2E), final current (2F), slope up (2C), starting current (2B), pre-gas (2A), and post gas (2G).

Again, we do not recommend using the 4t mode with either the foot pedal or the torch mounted amperage control.

D4) TIG SPOT – From the 4T Mode, depressing the welding mode (D) button once will put you in the “Tig Spot” (D4) Mode. The spot welding mode allows you to weld for between 0.1 and 10 seconds and then the unit will automatically stop. This would be a good selection if you were performing a series of repetitive tack welds.

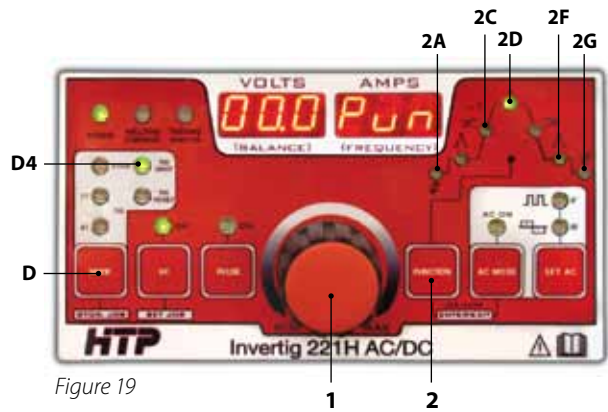

Figure 19

As shown in Fig 19, the “TIG SPOT” light (D4) is illuminated and the amps display will flash “Pun” for point or spot. When the display stops flashing, the peak welding current will be displayed in the “AMPS” digital display, and the welding voltage will be displayed in the “VOLTS” digital display (00.0 unless you are welding).

To adjust the spot welding time, press the “FUNCTION” button once and the amps display will flash “tin” for time. (the display can’t form an “m”) When “tin” disappears the number in “AMPS” digital display will show the spot weld time. Using the Encoder (1) select a spot weld time between 0.1sec and 10.0 sec.

Welding parameters which can be adjusted are Spot time (2C), final current (2F), pre-gas (2A), and post gas (2G). The spot weld function works in AC and DC with or without pulse.

D5) TIG REPEAT– From the TIG Spot Mode, depressing the welding mode (D) button once will put you in the “TIG Reset” Mode. Using a TIG torch which has a trigger switch, the TIG Reset mode allows you to switch between 2 pre-programmed welding amperages.

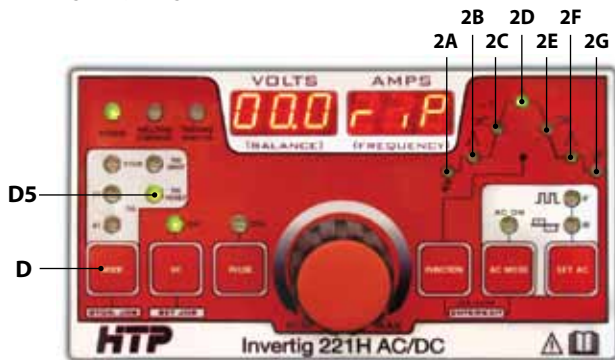

Figure 20

As shown in Fig 20, the “TIG REPEAT” light (D5) is illuminated and the amps display will flash “rIP” for TIG Repeat. When the display stops flashing, the peak welding current will be displayed in the “AMPS” digital display, and the welding voltage will be displayed in the “VOLTS” digital display (00.0 unless you are welding).

For example, you have your welding current set at 150 amps, and your “FINAL CURRENT” set at 50% or 75 amps. Depress the trigger and you have pre-gas flow for as long as you keep the trigger depressed. Release the trigger and your TIG 221 will begin to weld at 150 amps. Depress and release the trigger and you will go to your final current of 75 amps. Depress and release the trigger again and you will go back to 150 amps. To stop welding, depress the trigger for 5 seconds or longer. When the trigger is released the arc is extinguished and the machine will go into post gas flow.

Welding parameters which can be adjusted using the encoder are slope down (2E), final current (2F), slope up (2C), starting current (2B), pre-gas (2A), and post gas (2G).



E

E) HF ON – Depressing the “HF ON” button (E) so the green light is illuminated turns the high frequency arc starting on. When the foot pedal or torch trigger is depressed, a high frequency arc will jump from the tungsten to the grounded workpiece, initiating the arc. This makes it very easy to start the arc, and also eliminates the possibility of tungsten contamination from touching the work piece with the tungsten.

On your Invertig 221, in the AC mode, the high frequency is only used to start the arc, unlike conventional transformer welders which must have the high frequency on all the time to maintain the arc.

When the high frequency is off, it is possible to do “lift arc” starting. The lift arc mode allows you to initiate the welding arc without high frequency. This is important in any environment where the high frequency arc will cause interference with sensitive electrical components or computers. A good example of this would be stainless steel or aluminum repair in hospitals. The Lift Arc mode works for both AC and DC welding.

To TIG Weld using the Lift Arc Mode, simply touch the tungsten to the workpiece, activate the torch trigger or depress the foot pedal and lift off. When the tungsten breaks contact with the work, the arc will start.

For Lift-Arc in aluminum, please remember the following pointers to make arc ignition easier:

- 1) Keep the tungsten in contact with the workpiece for at least 5 seconds before lifting off the work piece.
- 2) When using remote amperage control, it is advisable to start the arc at a much higher amperage than the actual welding amperage. Once the arc has been established, reduce the amperage to the welding amperage.
- 3) For Lift Arc at lower amperages, the correct tungsten (2% Ceriated) correct diameter, and a correctly ground tungsten are very important.
- 4) A higher frequency (200 Hz) and higher balance (90%) will make it easier to initiate your arc.

F) PULSE ON – by depressing the “PULSE” button (F), the green light will illuminate indicating your Invertig 221 is in the pulse mode. At this time the “AMPS” display will show “P.Fr” for the pulsing frequency. (See Fig 21)



Figure 21

F 1

Then a flashing number will come into the display which will be the pulse frequency. While the number is flashing you can adjust the pulse frequency using the encoder (1) from .4 PPS (pulses per second) to 999 PPS in DC, and from .4 PPS to 10 PPS in AC.

Depressing the “PULSE” button twice brings “P.du” into the display. (See Fig 22) Then a flashing number will come into the display which will be the pulse duty cycle or “peak welding time” or just “peak time”. This is the percentage of the cycle the machine will be welding at the “peak welding current”. While the number is flashing you can adjust the peak time from 10% to 90% of the welding cycle in increments of 1%.



Figure 22

F 1

The final pulse welding parameter is the “background current”. To adjust the background current, depress the “FUNCTION” (2) button twice and “ILo” will appear in the display (I for amperage and Lo for background).



Figure 23

F 1 2

Then a flashing number will come into the display which will be the background current as a percentage of the peak welding current. While the number is flashing you can adjust the background current using the encoder (1) from 10% to 90% of the peak welding current in increments of 1%.

So let's do a common sense example. To make the math easy we will set the pulse frequency (P.Fr) to 1.0 pulse per sec. We will set the peak current (A) to 100 amps, the peak time to (P.du) to 25%, and the background current (ILo) to 35%. Now let's assume we are hammer down on the pedal, so we are welding at 100 amps. Your 221 will pulse once every second. The peak time is set to 25%, so for 25% of your 1 second pulse (¼ sec (.25 sec)) your 221 will be welding at 100 amps. The background current is set to 35%, or 35% of 100 amps, which is 35 amps. So for the remainder of the pulse, (¾ sec (.75 sec)) the machine will drop down to the background current which is 35 amps. It will then repeat the cycle.

It is important not to set your background current too low, or the peak time too short or the weld puddle may freeze, which could cause cracking.

To turn off the pulse mode, depress the “PULSE” (F) button at least 3 seconds until the green pulse light goes off.

Welding Volts - Digital Display

The Welding Volts Digital Display is a multi-function display. When you are welding, this displays the welding voltage.

Pressing other touch pad buttons will display other parameters in the “VOLTS” display. Those displays will be covered in the section covering those touch pad buttons.

Welding Amps - Digital Display

The Welding Amps Digital Display is a multi-function display. When you are welding, this displays welding amperage.

Pressing other touch pad buttons will display other parameters in the “VOLTS” display. Those displays will be covered in the section covering those touch pad buttons.

Adjusting the Starting Current – There may be times when you want the starting current to start at a higher setting than the default starting current which is 4 amps when welding in the 2 t mode and using a remote amperage control.



Figure 24

1 2

To change the starting current, depress the “FUNCTION” button (2) until “oFS” appears in the amperage display. When “oFS” appears in the display, release the FUNCTION button, and while the display is flashing, adjust the starting current using the encoder (1). The starting current can be adjusted from 4 to 100 amps in increments of 1 amp. Do not set the starting current higher than your peak current.

Storing Welding Programs – Your Invertig 221 will store 64 separate welding programs which you can recall for specific welding jobs. You will see under the “FUNCTION” button (2) and the “AC MODE” button (3) it says “job mode – enter/exit”.

First, make sure all the parameters you want to store are set on your 221. The machine must be set beforehand.



Figure 25

To enter the job mode, depress the function button (2) first and then AC Mode button (3) second, and keep both buttons depressed until the machine beeps twice and “PrG” comes into the volts display, and a number between 1 and 64 comes into the amps display (see fig 25). You can use the encoder (1) to adjust the program from anywhere between 1 and 64. The number in the display is where your welding program will be stored. For this example, let’s set the program to 1.

Recalling Welding Programs – to recall welding programs, enter the job mode by depressing the function button (2) first and then AC Mode button (3) second, and keep both buttons depressed until the machine beeps twice and “PrG” comes into the volts display. Using the encoder (1) adjust the volts display to the number you want to recall.



Figure 27

Depress the “HF” (set job) button (E) and hold. The machine will beep and “rEc” will flash in the volts display. Keep the set job button depressed until the machine beeps again and release. The machine will continue to beep and when it stops, your program will be recalled.



Figure 26

Next, depress “MODE” (stor. job) button (D) and keep it depressed. “Sto” will flash and come into the volts display and the amps display will show the program number. Keep the “MODE” button depressed and you will hear the machine beep. When it starts beeping release the mode button. The machine will beep a total of 4 times and when finished your program will be stored.

We strongly advise you keep track of your welding programs by writing them down or by putting them in an excel spreadsheet.

Tungsten Electrodes

With conventional transformer TIG welders, the general rule of thumb is to use a pure tungsten (identified by a green tip) for AC welding (generally aluminum), and a 2% thoriated tungsten (identified by a red tip) for DC welding (generally steel welding). However, with an inverter TIG welder, the ability to control the frequency and balance over a much wider range allows you to take advantage of the new "rare earth" tungsten which is now available.

A 2% Ceriated tungsten is the best tungsten selection for both AC and DC welding with your new HTP Invertig 221.

HTP offers the following premium quality tungsten ground to a high quality finish. All tungsten is 7" long and can be purchased individually.

Pure Tungsten (TP): green tip - Pure tungsten readily forms a ball on the end. It is generally used with transformer based power sources for AC welding of aluminum.

2% Thoriated Tungsten (TT2): red tip - This tungsten is the most common tungsten currently used. Generally used for DC welding of steel and stainless steel. Draw back is it has a low level radiation hazard. Offers good overall performance.

2% Ceriated Tungsten (TC2): grey tip - 2% ceriated is an excellent substitute for 2% thoriated tungsten if you are using a transformer based power source for DC welding. More popular for thinner materials because it requires less amperage to start. Offers a stable arc. Can be used for both AC and DC welding with inverter power sources.

2% Lanthanated Tungsten (TL2): blue tip - 2% lanthanated is probably the most popular substitute for 2% thoriated tungsten. It offers good arc starting characteristics and longer life than 2% thoriated. Can be used for both AC and DC welding with both inverter and transformer power sources.



Tungsten Type	Diameter			
	.040" (1.0mm)	1/16" (1.6mm)	3/32" (2.4mm)	1/8" (3.2mm)
Pure Tungsten	TP-7040	TP-7116	TP-7332	TP-718
2% Thoriated	TT2-7040	TT2-7116	TT2-7332	TT2-718
2% Ceriated	TC2-7040	TC2-7116	TC2-7332	TC2-718
2% Lanthanated	TL2-7040	TL2-7116	TL2-7332	TL2-718
Amperage - AC	20-30	30-80	60-130	120-200
Amperage - DC	15-50	50-120	80-150	130-250



Tungsten Sharpener

The electrode should be sharpened to a point with a fine grinding wheel. If the stone used for sharpening the electrode is not clean, contaminants could lodge in the electrode and dislodge when welding. The grinding wheel used for tungsten electrodes should not be used for any other materials. When grinding the electrode to a point, a 15 to 30 degree angle is desired. The grinding marks should run lengthwise with the point, opposed to in the direction of the diameter.

The HTP Tungsten Sharpener is an excellent tool for precisely sharpening tungsten electrodes without any fear of contamination.

General Welding Parameters

Following are some “rule of thumb” welding parameters, tungsten diameters, and amperage settings for welding different thicknesses of aluminum and steel. Keep in mind these are general settings and the specific application may require more or less power to get the job done.

Aluminum

Thickness	Tungsten Diameter	Machine Amperage	Welding Amperage	Filler Diameter
.030"	.040"	50	30-40	1/16"
.050"	1/16"	70	50-60	1/16"
.062" (1/16")	1/16"	80	65-75	1/16"
.093" (3/32")	3/32"	120	105-115	3/32"
.125" (1/8")*	3/32"	150	125-135	3/32"
.187" (3/16")*	1/8"	170	150-160	1/8"
.250" (1/4")*	1/8"	200	180	1/8"
.312" (5/16")	1/8"	220	220	1/8"

*May require beveling—depends on joint

Steel

Thickness	Tungsten Diameter	Machine Amperage	Welding Amperage	Filler Diameter
.030"	.040"	50	30-40	1/16"
.050"	1/16"	70	50-60	1/16"
.062" (1/16")	1/16"	80	65-75	1/16"
.093" (3/32")	3/32"	120	105-115	3/32"
.125" (1/8")*	3/32"	150	125-135	3/32"
.187" (3/16")*	1/8"	170	150-160	1/8"
.250" (1/4")*	1/8"	200	180	1/8"
.312" (5/16")	1/8"	220	220	1/8"

* May require beveling—depends on joint

Quick Set Up

- 1) Welding Mode in 2T for foot pedal or hand control.
- 2) Steel welding AC off—Aluminum welding AC on.
- 3) Slope down—0.1 Seconds
- 4) Pre gas flow—0.4 Seconds
- 5) Post gas flow—8 Seconds
- 6) Frequency—150 Hz for aluminum. Not applicable for steel.
- 7) Balance—65-75% for aluminum. Not applicable for steel.
- 8) Independent AC amperage off (AC on light will not be flashing). Not applicable for steel.
- 9) Ground clamp plugged into the Positive receptacle.
- 10) TIG torch plugged into Negative receptacle.
- 11) Foot pedal or hand control plugged into 7-pin receptacle; flashing light in lower right-hand corner of the Amp display indicated remote is connected.
- 12) Pulse off.
- 13) Gas flow—100% Argon set to 15 to 20 CFH while the gas is flowing.

*Amperage “rule of thumb”: 1 amp per .001 inches.

Filler Rod

Part#	Material	Size & Weight
4043-116-36-2	4043 Alloy Aluminum	1/16" x 36" x 2 Lbs.
4043-332-36-2	4043 Alloy Aluminum	3/32" x 36" x 2 Lbs.
5356-116-36-2	5356 Alloy Aluminum	1/16" x 36" x 2 Lbs.
5356-332-36-2	5356 Alloy Aluminum	3/32" x 36" x 2 Lbs.
308L-045-36-2	308L Stainless Steel	.045" x 36" x 2 Lbs.
308L-116-36-2	308L Stainless Steel	1/16" x 36" x 2 Lbs.
70S6-116-36-2	ER70S-6 Mild Steel	1/16" x 36" x 2 Lbs.
70S6-332-36-2	ER70S-6 Mild Steel	3/32" x 36" x 2 Lbs.
70S2-116-36-2	ER70S-2 Steel	1/16" x 36" x 2 Lbs.
80SD2-116-36-2	ER80S-D2 Steel	1/16" x 36" x 2 Lbs.

Filler Rod for TIG Welding

HTP offers you high quality filler rods in affordable quantities. All filler rod is packaged in 2 lb. or 10 lb. packages that keep your filler rod fresh and contaminant free.

In TIG welding, the filler rod is fed into the molten puddle by hand. The choice of filler rod is extremely important as the rod must correctly match the material and alloy you will be welding. The thickness of the material to be welded determines the diameter of the filler rod.

Here are some good “rules of thumb” to help you select the correct filler material:

- 1) 4043 is a good filler metal for most aluminum applications. Remember 2xxx and 7xxx series aluminum is generally not recommended if the application requires welding.
- 2) 5356 is used for 5xxx series aluminum and is generally preferred if the finished piece will be anodized or needs to be salt water corrosion resistant like in marine applications.
- 3) ER70S-6 is generally used for mild steel welding.
- 4) ER70S-2 is highly recommended for welding 4130 chrome-moly tubing in many applications.
- 5) ER80S-D2 is recommended for welding 4130 chrome-moly tubing if a higher strength, less ductile weld is required. If your weld will be heat treated to obtain optimum strength, then use a filler metal which matches the chemistry of your tubing, which neither 70S-2 nor 80S-D2 wires do.
- 6) Use 308 for most grades of stainless steel.
- 7) Use 309 or 312 for dissimilar metals or welding mild steel to stainless steel.
- 8) Generally speaking, use 1/16" diameter filler rod for applications where the material is 1/8" and thinner. Use a 3/32" diameter filler rod for applications where the material is 1/8" and thicker.

17 Series Air-Cooled TIG Torch Parts Breakdown

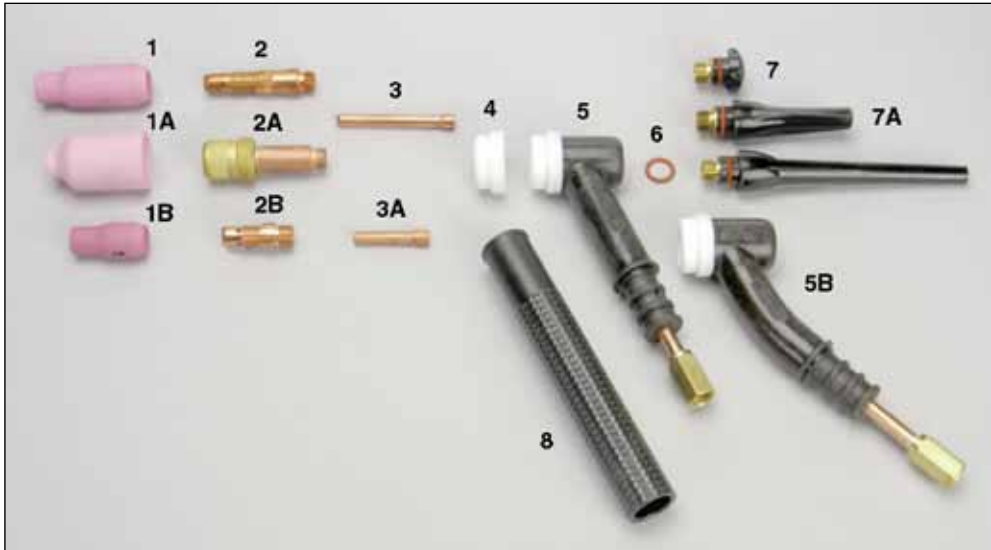

Illus #	Description	Tungsten Diameter			
		0.040"	1/16"	3/32"	1/8"
Standard Configuration					
1	Alumina Nozzle	10N49	10N48	10N47	10N46
2	Collet Body	10N30	10N31	10N32	10N28
3	Collet	10N22	10N23	10N24	10N25
Gas Lens Configuration (optional)					
1A	Alumina Nozzle	54N17	54N16	54N15	54N14
2A	Gas Lens Collet Body	45V24	45V25	45V26	45V27
3	Collet	10N22	10N23	10N24	10N25
Short Configuration (optional)					
1B	Alumina Nozzle	13N08	13N09	13N10	13N11
2B	Collet Body	17CB20	17CB20	17CB20	17CB20
3B	Collet	13N21	13N22	13N23	13N24

Following parts fit all tungsten diameters

4	Cup Gasket (Std & Short)	18GC
	Cup Gasket (Gas Lens)	3GHS
5	Torch Head	SR-17
5B	Flexible Torch Head	SR-17F
6	O-Ring	98W18
7	Short Back Cap	300S
7A	Medium Back Cap	300M
7B	Long Back Cap	300L
8	Handle	H-100

20 Series Water Cooled TIG Torch Parts Breakdown

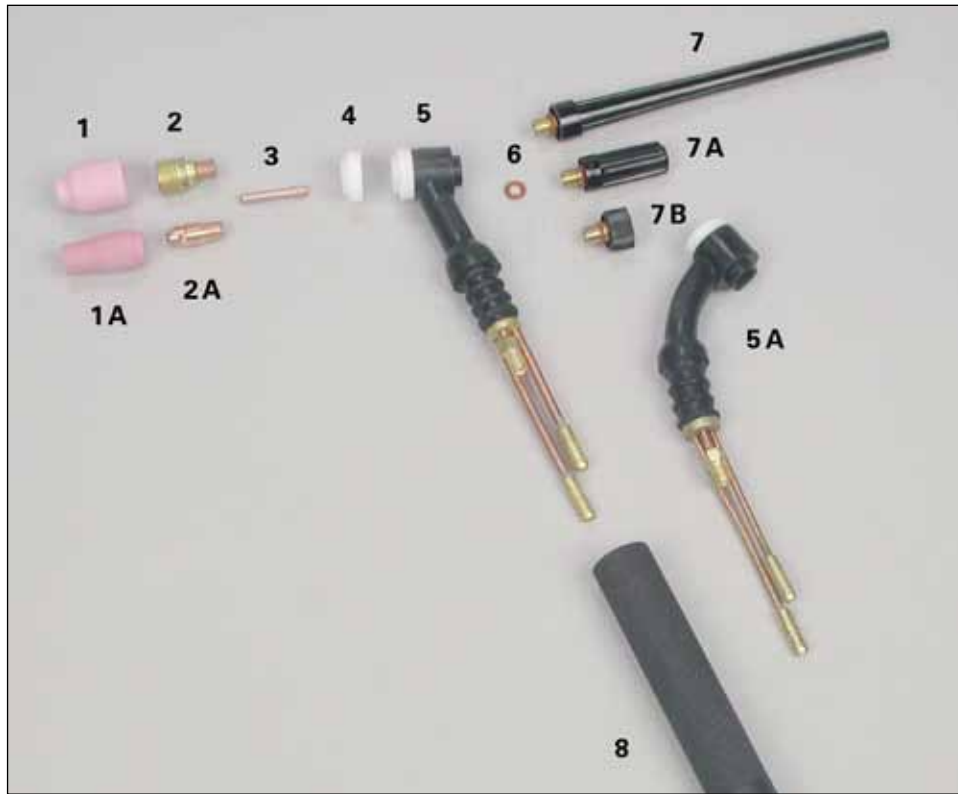

Illus #	Description	Tungsten Diameter			
		0.040"	1/16"	3/32"	1/8"
Gas Lens Configuration (optional)					
1	Alumina Nozzle	53N59	53N60	53N61	53N61S
2	Gas Lens Collet Body	45V42	45V43	45V44	45V45
3	Collet	13N21	13N22	13N23	13N24
Standard Configuration					
1A	Alumina Nozzle	13N08	13N09	13N10	13N11
2	Collet Body	13N26	13N27	13N28	13N29
3	Collet	13N21	13N22	13N23	13N24

Following parts fit all tungsten diameters

4	Cup Gasket	2GHS
5	Torch Head	20
5A	Flexible Torch Head	20F
6	O-Ring	200R
7	Long Back Cap	200L
7A	Medium Back Cap	200M
7B	Short Back Cap	200S
8	Handle	20HR

Pyrex Parts

Pyrex Cup Kits

Nothing makes welding easier than being able to see what you are doing. HTP's Pyrex Cup kits do just that! The clear Pyrex cup gives you unparalleled visibility of the arc and work. The Pyrex Cup kit also comes standard with our special gas saver gas lens kit. This unique system saves gas while at the same time providing better gas coverage with a more even and uniform gas flow. Eliminates gas turbulence which can cause weld quality problems. Pyrex cup kits are available to fit all standard torches. There is even a special large diameter kit available for welding titanium.

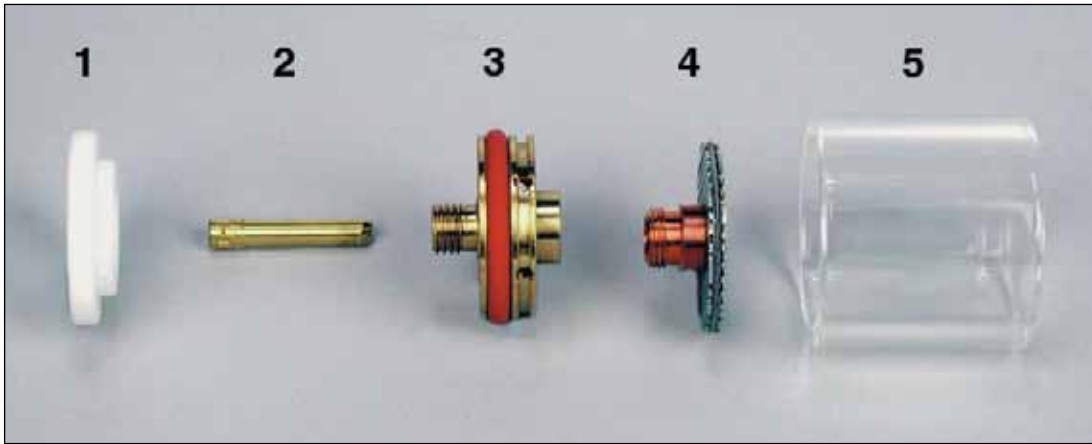

Pyrex-Big Parts

Large Diameter Pyrex Cup Kits

Illus #	Description	Tungsten Diameter			
		0.040"	1/16"	3/32"	1/8"
<i>9 and 20 Series TIG Torches</i>					
1	Heat Shield	2HSGSLD	2HSGSLD	2HSGSLD	2HSGSLD
2	Wedge Collet	PYR20C040	PYR20C116	PYR20C332	PYR20C18
3	Collet Body	PYR20LDCB	PYR20LDCB	PYR20LDCB	PYR20LDCB
4	Tungsten Adapter	PYR040TA-LD	PYR116TA-LD	PYR332TA-LD	PYR18TA-LD
5	Pyrex Cup	PYR20LD	PYR20LD	PYR20LD	PYR20LD
	Complete Kit	PYREX20LD-040	PYREX20LD-116	PYREX20LD-332	

PYREX20LD-18

<i>17, 18, and 26 Series TIG Torches</i>					
1	Heat Shield	4HSGSLD	4HSGSLD	4HSGSLD	4HSGSLD
2	Wedge Collet	PYR17SC040	PYR17SC116	PYR17SC332	PYR17SC18
3	Collet Body	PYR17LDCB	PYR17LDCB	PYR17LDCB	PYR17LDCB
4	Tungsten Adapter	PYR040TA-LD	PYR116TA-LD	PYR332TA-LD	PYR18TA-LD
5	Pyrex Cup	PYR17LD	PYR17LD	PYR17LD	PYR17LD
	Complete Kit	PYREX17LD-040	PYREX17LD-116	PYREX17LD-332	PYREX17LD-18



Pyrex Cup Parts

Illus #	Description	Tungsten Diameter			
		0.040"	1/16"	3/32"	1/8"
<i>For 9 and 20 TIG Torches</i>					
1	Pyrex Cup	PYR8S	PYR8S	PYR8S	PYR8S
2	Tungsten Adapter	PYR040TA	PYR116TA	PYR332TA	PYR18TA
3	Collet Body	PYR20CB	PYR20CB	PYR20CB	PYR20CB
4	Wedge Collet	PYR20C040	PYR20C116	PYR20C332	PYR20C18
5	Heat Shield	2HSGS	2HSGS	2HSGS	2HSGS
	Complete Kit	PYREX20-040	PYREX20-1/16	PYREX20-3/32	PYREX20-1/8
<i>For 17, 18, and Series 26 TIG Torches</i>					
Short Configuration					
1	Pyrex Cup	PYR8S	PYR8S	PYR8S	PYR8S
2	Tungsten Adapter	PYR040TA	PYR116TA	PYR332TA	PYR18TA
3A	Collet Body	PYR17SCB	PYR17SCB	PYR17SCB	PYR17SCB
3A	Wedge Collet	PYR17SC040	PYR17SC116	PYR17SC332	PYR17SC18
5A	Heat Shield	3HSGS	3HSGS	3HSGS	3HSGS
	Complete Kit	PYREX17S-040	PYREX17S-1/16	PYREX17S-3/32	PYREX17S-1/8
Standard Configuration					
1B	Pyrex Cup	PYR8L	PYR8L	PYR8L	PYR8L
2	Tungsten Adapter	PYR040TA	PYR116TA	PYR332TA	PYR18TA
3B	Collet Body	PYR17LCB	PYR17LCB	PYR17LCB	PYR17LCB
4B	Wedge Collet	PYR17LC040	PYR17LC116	PYR17LC332	PYR17LC18
5A	Heat Shield	3HSGS	3HSGS	3HSGS	3HSGS
	Complete Kit	PYREX17-040	PYREX17-1/16	PYREX17-3/32	PYREX17-1/8

FUPA & BBW Flared Cup Kits

Essential tools for serious fabricators, the large diameter **FUPA12C** Ceramic Cup Kit, **FUPA12** Pyrex Cup Kit, and **BBWSG-19** Pyrex Cup kit offer superb gas coverage—a necessity when making critical welds on exotic materials including Titanium, Chrome Moly, and Stainless Steel. All three cup kits fit 9, 17, and 26 Series air-cooled torches, as well as 18 and 20 Series water-cooled torches. While all three kits fit on a standard 45V44 gas lens collect body, please use one of the included o-rings when using either the **FUPA12** or **BBWSG-19** cup (the **FUPA12C** cup does not require the use of an o-ring).

If you own a 9 or 20 Series torch, please order part# **FUPA12C**, **FUPA1220CKIT**, **FUPA12**, **FUPA1220KIT**, **BBWSG-19**, or **BBWSG19-20KIT**.

- Part# **FUPA12C** includes two FUPA #12 flared ceramic cups and three diffusers (one diffuser for each cup and a spare diffuser).
- Part# **FUPA1220CKIT** includes a 3/32" gas lens collet body and a 3/32" wedge collet, in addition to the parts included in the FUPA12C kit.
- Part# **FUPA12** includes two #12 flared Pyrex cups with diffusers, a spare diffuser, and three spare o-rings.
- Part# **FUPA1220KIT** includes a 3/32" gas lens collet body and a 3/32" wedge collet, in addition to the parts included in the FUPA12 kit.
- Part# **BBWSG-19** includes two #16 flared Pyrex cups, one diffuser with o-ring, one spare diffuser o-ring, and three spare gas lens collet body o-rings.
- Part# **BBWSG19-20KIT** includes a 3/32" gas lens collet body and a 3/32" wedge collet, in addition to the parts included in the BBW16 kit.

If you own a 17, 18, or 26 Series torch, please order part# **FUPA1217CKIT**, **FUPA1217KIT**, or **BBWSG19-17KIT**.

- Part# **FUPA1217CKIT** includes two FUPA #12 flared ceramic cups, three diffusers (one diffuser for each cup and a spare diffuser), a 3/32" gas lens collet body, a 3/32" wedge collet, and a heat shield.
- Part# **FUPA1217KIT** includes two #12 flared Pyrex cups with diffusers, a spare diffuser, three spare o-rings, a 3/32" gas lens collet body, a 3/32" wedge collet, and a heat shield.
- Part# **BBWSG19-17KIT** includes two #16 flared Pyrex cups, one diffuser with o-ring, one spare diffuser o-ring, a 3/32" gas lens collet body, three spare gas lens collet body o-rings, a 3/32" wedge collet, and a heat shield.

If you already own **FUPA1217CKIT**, **FUPA1217KIT**, or **BBWSG19-17KIT**, and only require replacement cups and diffusers, you may purchase part# **FUPA12C**, **FUPA12**, or **BBWSG-19**.



EDGE Welding Supply Cups & Kits

We also recommend the use of EDGE Welding Supply's vast catalog of Pyrex and Quartz cups and kits. Here at HTP, we carry individual cups and other consumable parts, as well as premade kits which include the parts you need to tackle critical welding jobs on exotic materials, such as Inconel, Stainless Steel, and Titanium.

We recommend the following kits for DC welding applications with metals such as Inconel, Stainless Steel, and Titanium (up to 180 amps):

9 & 20 Series TIG Torches

Part#	Description
EDGE920-GLKIT	EDGE Gas Lens Pyrex Cup Kit
EDGE-EXP920	EDGE EXP Mini Collet Body Kit (Available with a #4, #5, or #6 Collet Body Pyrex Cup)
EDGE-XXL-KIT	EDGE XXL Gas Lens Pyrex Cup Kit
EDGE-LD-KIT	EDGE Large Diameter Gas Lens Pyrex Cup Kit (Does Not Include Adapter)

17, 18, & 26 Series TIG Torches

Part#	Description
EDGE17-GLKIT	EDGE Gas Lens Pyrex Cup Kit
EDGE17ST-GLKIT	EDGE Stubby Gas Lens Pyrex Cup Kit
EDGE-EXP17	EDGE EXP Mini Collet Body Kit (Available with a #4, #5, or #6 Collet Body Pyrex Cup)
EDGE-XXL-KIT	EDGE XXL Gas Lens Pyrex Cup Kit (Compatible when used with adapter P/N GL920-A; adapter not included)
EDGE-LDA-KIT	EDGE Large Diameter Gas Lens Pyrex Cup Kit (Includes Adapter)

We recommend the following kits for DC welding applications with any metal (up to 350 amps):

9 & 20 Series TIG Torches

Part#	Description
EDGE920Q-KIT	EDGE Quartz Cup Kit

17, 18, & 26 Series TIG Torches

Part#	Description
EDGE17Q-KIT	EDGE Quartz Cup Kit



EDGE920-GLKIT



EDGE-EXP920



EDGE-XXL-KIT

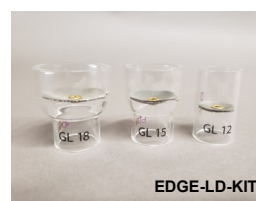

EDGE-LD-KIT



EDGE17-GLKIT



EDGE17ST-GLKIT



EDGE-EXP17



EDGE-LDA-KIT



EDGE920Q-KIT



EDGE17Q-KIT

Invertig 221 AC/DC (Single Voltage) Parts Diagram & List

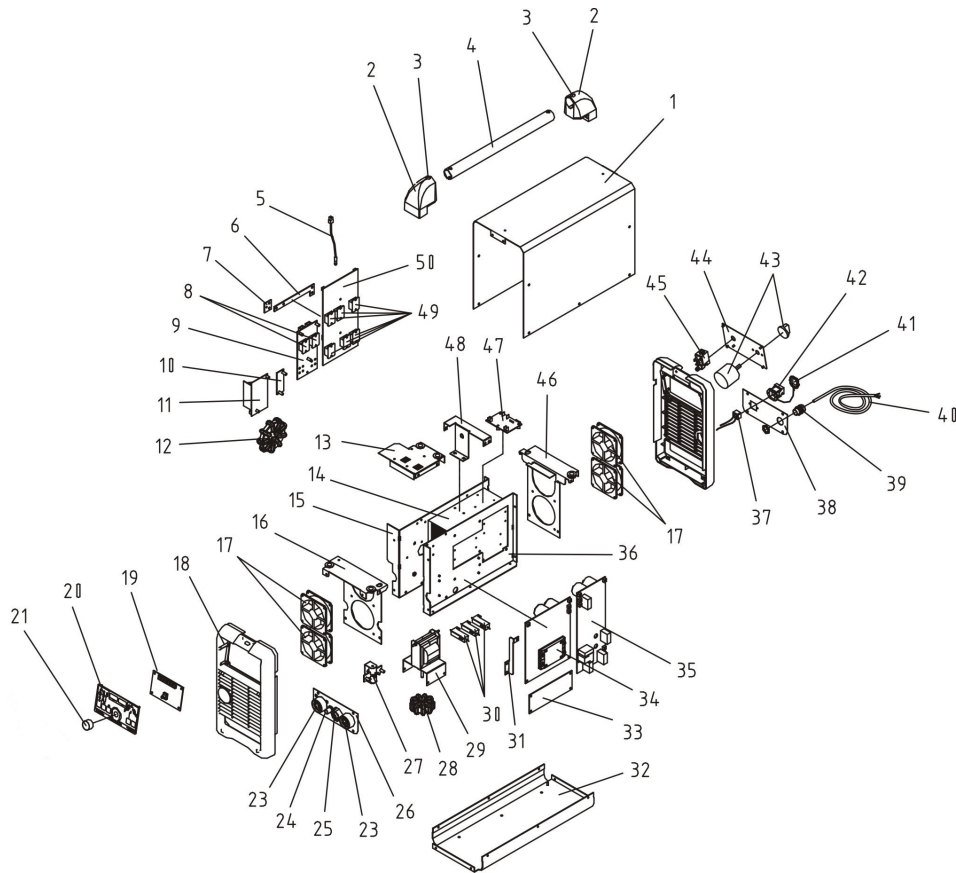

Pos.	Description	Part#	Pos.	Description	Part#
1	Cover	620148	27	Shunt	612644
2	Handle Support	660752	28	XL	612556
3	Screw Cover	660754	29	Power Transformer	612039
4	Handle	620212	30	Resistance	612145
5	NTC (Preassembled)	611076	31	Front PCB Support	620242
6	Copper Bar ("L" Shape)	620256	32	Cabinet Bottom	620147
7	Copper Bar (Square)	620257	33	Fly-Back PCB	612017
8	Diode	650302	34	Primary Power PCB	612014
9	Secondary Power PCB	612015	35	Primary Rectifier PCB	612018
10	Filter PCB	611415	36	Heat Sink Support (Right)	620149
11	High Frequency PCB	611435	37	Female AC5460 Receptacle	645560
12	Elevator Transformer	612166	38	Power Cable Support Plate	620211
13	Deflector Bracket	620254	39	Power Cable Strain Relief	660785
14	Extruded Aluminum Heat Sink	634160	40	Input Power Cable	647610
15	Heat Sink Support (Left)	620151	41	AC5460 Receptacle Cover	645580
16	Front Fan Support	620153	42	AC5460 Receptacle Housing	645540
17	Cooling Fan	612253	43	Switch	641940
18	Front and Rear Housing	660751	44	Switch Support Plate	620208
19	Logic PCB Group	612349	45	Solenoid Valve	617030
20	Front Label	661027	46	Rear Fan Support	620154
21	Adjustment Knob	660798	47	Clamper PCB	612021
23	Ground Receptacle/Socket	642740	48	PCB Intermediate Support	620241
24	Shield Gas Outlet	631970	49	IGBT	650559
25	7-Pin Female Receptacle	645380	50	AC/DC Converter PCB	612016
26	Support Plate (Front Panel Connections)	620209			

Invertig 221 AC/DC (Single Voltage) Wiring Diagram

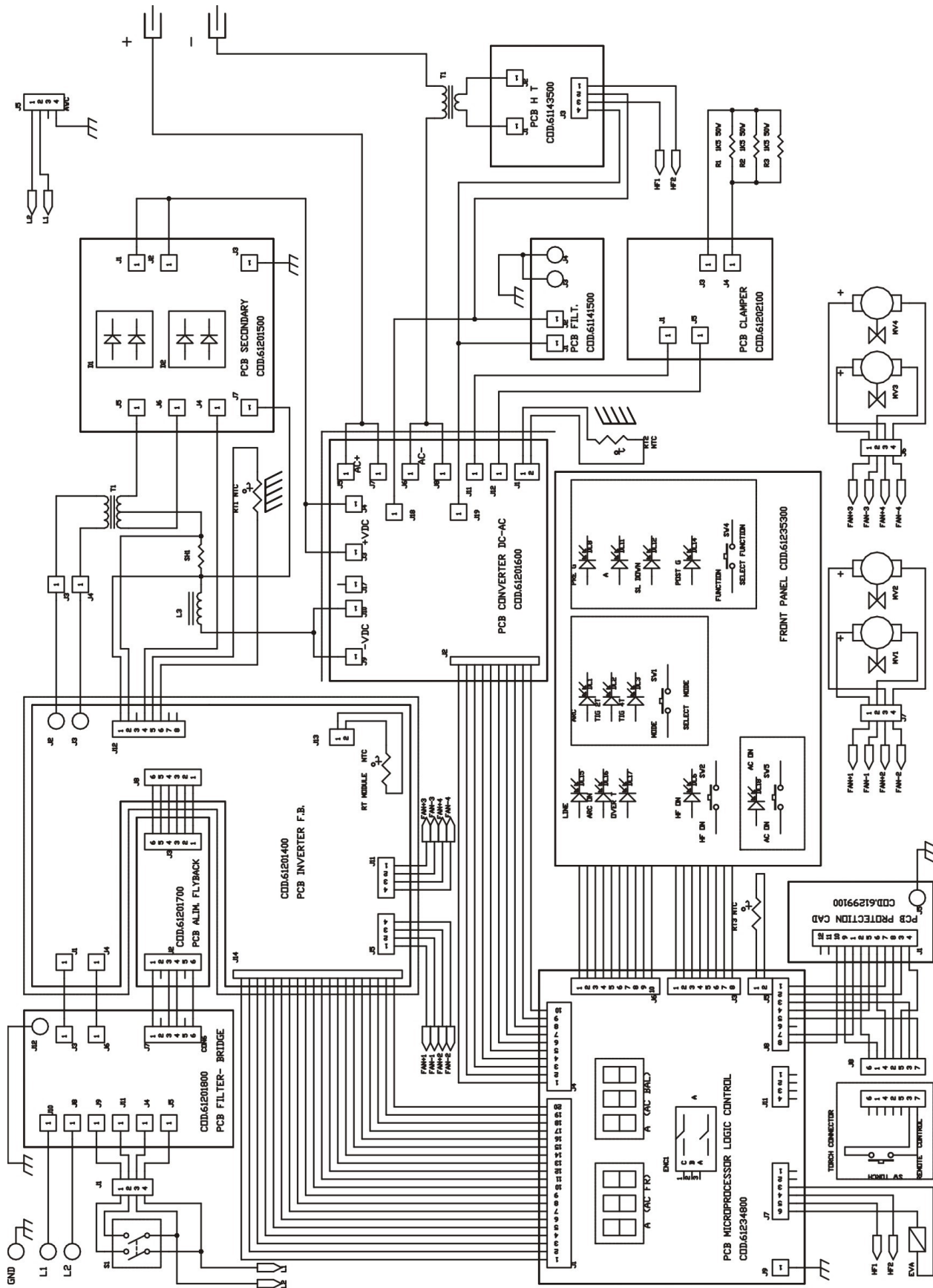

Invertig 221DV AC/DC (Dual Voltage) Parts Diagram & List

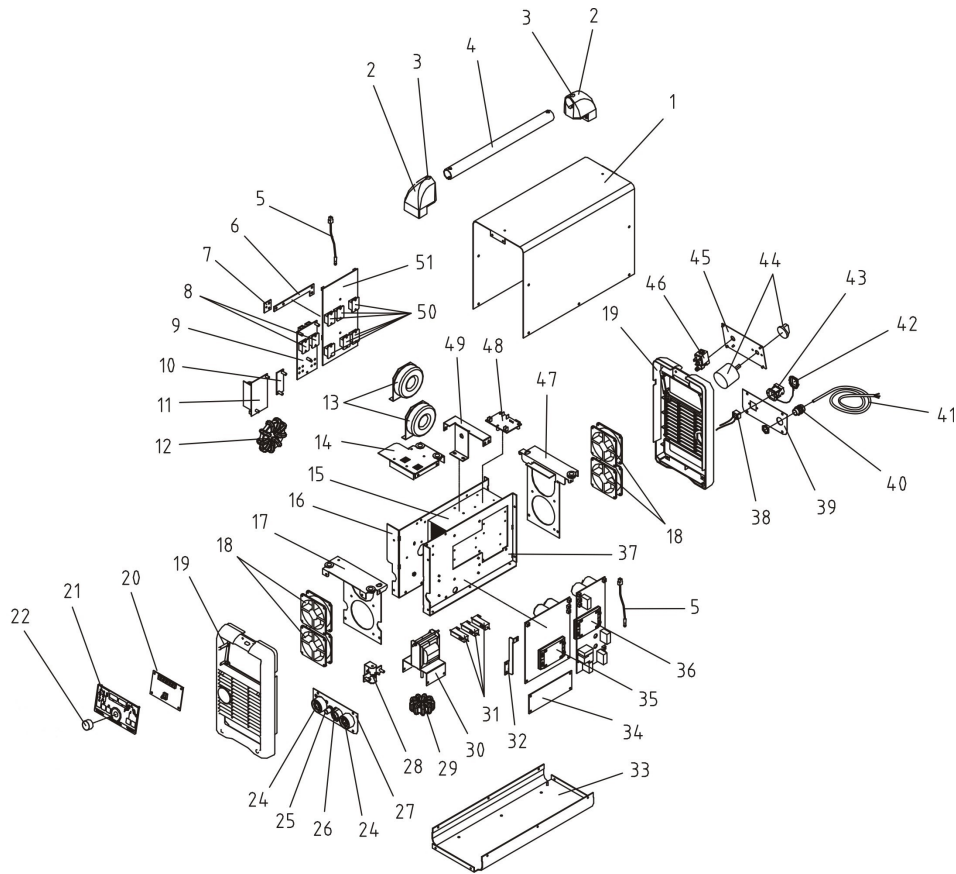

Pos.	Description	Part#	Pos.	Description	Part#
1	Cover	620148	27	Support Plate (Front Panel Connections)	620209
2	Handle Support	660752	28	Shunt	612644
3	Screw Cover	660754	29	XL	612556
4	Handle	620212	30	Power Transformer	612169
5	NTC (Preassembled)	611076	31	Resistance	612145
6	Copper Bar ("L" Shape)	620256	32	Front PCB Support	620242
7	Copper Bar (Square)	620257	33	Cabinet Bottom	620147
8	Diode	650302	34	Fly-Back PCB	612282
9	Secondary Power PCB	612015	35	Primary Power PCB	612014
10	Filter PCB	611415	36	Primary Rectifier PCB	612147
11	High Frequency PCB	611435	37	Heat Sink Support (Right)	620149
12	Elevator Transformer	612166	38	Female AC5460 Receptacle	645560
13	XL PFC	612146	39	Power Cable Support Plate	620211
14	Deflector Bracket	620254	40	Power Cable Strain Relief	660785
15	Extruded Aluminum Heat Sink	634160	41	Input Power Cable	647610
16	Heat Sink Support (Left)	620151	42	AC5460 Receptacle Cover	645580
17	Front Fan Support	620153	43	AC5460 Receptacle Housing	645540
18	Cooling Fan	612253	44	Switch	641940
19	Front and Rear Housing	660751	45	Switch Support Plate	620208
20	Logic PCB Group	612667	46	Solenoid Valve	617030
21	Front Label	661028	47	Rear Fan Support	620154
22	Adjustment Knob	660798	48	Clamper PCB	612021
24	Ground Receptacle/Socket	642740	49	PCB Intermediate Support	620241
25	Shield Gas Outlet	631970	50	IGBT	650559
26	7-Pin Female Receptacle	645380	51	AC/DC Converter PCB	612016

Invertig 221DV AC/DC (Dual Voltage) Wiring Diagram

