

Specifications:

Canopy

Machined 6061-T6 aluminum, C36000 brass, or 304 stainless steel.

Fixture Mount

Ø7/8" non-threaded fixture mount hole.

Mounting

Two mounting holes, 2" on center, for mounting machined tree canopy to a tree (hardware not supplied).

Finish

TGIC thermo set polyester powder coat paint available in 14 standard colors. On aluminum model, finish is applied over a corrosion resistant, hexavalent chromium free, RoHS compliant coating. Aluminum model available in one additional metal finish: Clear Anodized. Brass model available in three additional metal finishes: Natural, Polished, and Aged. Stainless steel model available in three additional metal finishes: Natural, Polished, and Brushed.

Electrical

For use with low voltage lighting fixtures only. Requires the use of a remote transformer.

Certification

CSA tested & certified to US and Canadian safety standards for wet location use.

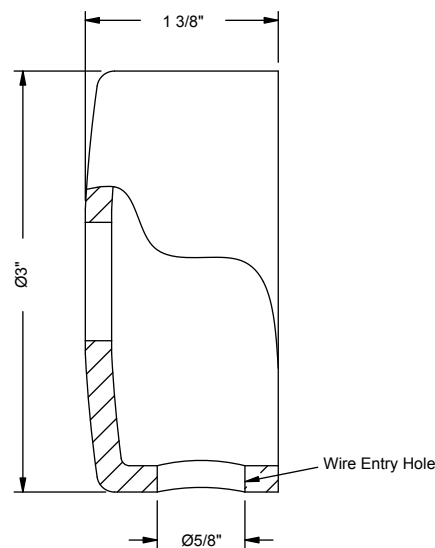
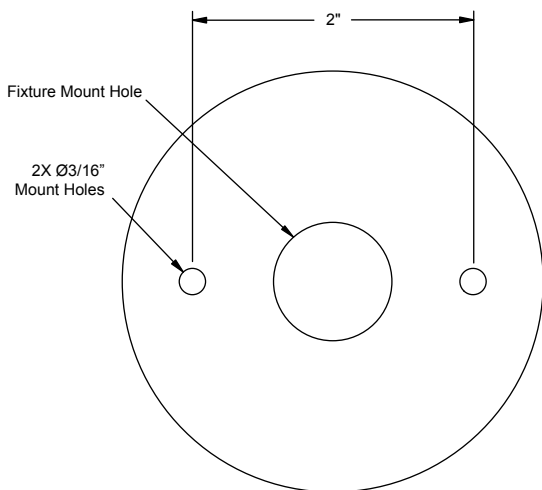

Ordering Information:

Model	Finish
MO10A - Aluminum	Powder Coat Finishes:
MO10B - Brass	BL - Black
MO10S - Stainless	BLT - Textured Black
	BN - Bronze
	BNT - Textured Bronze
	BAT - Textured Bark
	WI - White
	GRT - Textured Green
	SI - Silver
	GY - Grey
	BE - Beige
	GNT - Textured Granite
	SAT - Textured Sand
	PAT - Textured Patina
	EAT - Textured Earth
	Metal Finishes:
	CLA - Clear Anodized (MO10A only)
	NAT - Natural (MO10B & MO10S only)
	POL - Polished (MO10B & MO10S only)
	AGE - Aged (MO10B only)
	BRU - Brushed (MO10S only)

Notes:

1. Specifications, certifications, and ordering information are subject to change. Please check website for latest specification sheets.

Example: **MO10B - SI**