

PRODUCT FEATURES

- Handsome design featuring strong lines and contemporary finishes
- Provides ample task lighting distribution onto surfaces below
- Ideal for residential and commercial lighting applications
- Ships with an energy efficient integrated LED lamp
- Fully dimmable integrated LED lamping creates the desired ambiance
- Protected by a 5-year warranty



LAMPING

At 40 watts of LED strips, it will provide incredible illumination in virtually any environment 1952.1 delivered lumens, 90 CRI 3000K LED. Includes twelve feet of field-cutttable satin cable. Dimmable with most LED compatible ELV or Triac dimmer. 277V compatible with 0-10V dimmers. Can be installed on a sloped ceiling up to 45°.

Satin Nickel



Black

Satin Nickel

ORDERING INFORMATION

700LSKNOX FINISH

- B BLACK
- S SATIN NICKEL

LAMP

- LED LED 90 CRI 3000V 120V
- LED277 LED 90 CRI 3000V 277V

700LSKNOX _____

JOB NAME _____

NOTES _____



KNOX LINEAR SUSPENSION

SPECIFICATIONS

HARDWARE MATERIAL	Metal
SHADE MATERIAL	Acrylic
NET WEIGHT	18 lbs
HEIGHT	2.2in
WIDTH	3.6in
LENGTH	45.2in
UP LIGHT / DOWN LIGHT / BOTH?	
WET LISTED	
DAMP LISTED	Yes
DRY LISTED	
MIN. HANGING HEIGHT	9.4in
MAX HANGING HEIGHT	147.4in
TOTAL CORD LENGTH	144in
TOTAL STEM LENGTH	
STEM QTY	
SLOPED CEILING ADAPTABLE?	Yes 45° Max
GENERAL LISTING	ETL Listed
INCLUDES	

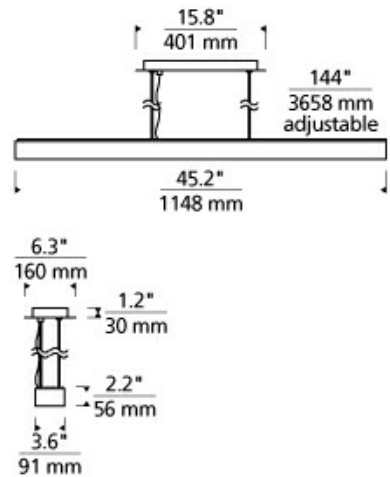

LAMPING SPECIFICATIONS

	LED LAMP	INTEGRATED LED	NON LED	NO LAMP
DELIVERED LUMENS		1952		
WATTS		40		
MAX WATTAGE PER BULB		40W		
INPUT VOLTAGE		120V 277V		
DIMMING TYPE*		ELV, TRIAC 0-10V		
CCT		3000K		
CRI		90 CRI		
LED LIFETIME		>50000		
L70				
AVERAGE BULB HOURS				
FIELD SERVICEABLE LED				
LAMP BASE		Integrated LED		
LAMP SHAPE		Integrated LED		
LAMP INCLUDED?		True		
WARRANTY**		5 Years		

* Dimming information available at www.techlighting.com/Downloads#dimming

** Visit techlighting.com for specific warranty limitations and details.

T20 / T24 / JA8 INFORMATION

	Integrated LED	Replacement LED Lamp	No Lamp *
This product can be used to comply with California Building Energy Efficiency Standards 2016 Title 24 Part 6 / JA8.	Yes		
This product can be used to comply with California Appliance Efficiency Standards 2016 Title 20 and may be shipped to and sold in California.	N/A		

* If a light fixture or component does not include a lamp or light source, it is the responsibility of the customer to select a lamp that meets the T24 and T20 requirements.

