

## SL270 WALL SCONCE WITH CONDUIT BOX INSTALLATION INSTRUCTIONS

- ! WARNING:** IMPORTANT SAFEGUARDS, READ AND FOLLOW ALL SAFETY INSTRUCTIONS.
- ! WARNING:** TO AVOID FIRE, SHOCK OR DEATH, TURN OFF AND LOCKOUT POWER BEFORE PERFORMING ANY MAINTENANCE.
- ! CAUTION:** THIS FIXTURE MUST BE WIRED IN ACCORDANCE WITH THE NATIONAL ELECTRIC CODE AND ALL APPLICABLE LOCAL CODES. PROPER GROUNDING IS REQUIRED. ALL WORK SHOULD BE DONE BY A QUALIFIED ELECTRICIAN.
- ! SAVE THESE INSTRUCTIONS.**

1. Apply silicone bead to the back of the conduit box as shown. **SEE FIGURE 1.**
2. Attach conduit box mounting bracket to wall (customer supplied hardware). **SEE FIGURE 2.**
3. Attach conduit box front casting to the fixture using mounting screws and supplied lock washers and nuts. **SEE FIGURE 3.**
4. Attach conduit as required (customer supplied). 3/4" NPT threaded holes are provided on both sides of the conduit box. **SEE FIGURE 4.**
5. Attach supply wires to fixture wires.
6. Attach fixture assembly to mounting bracket with supplied screws. **SEE FIGURE 4.**

**FIGURE 1**

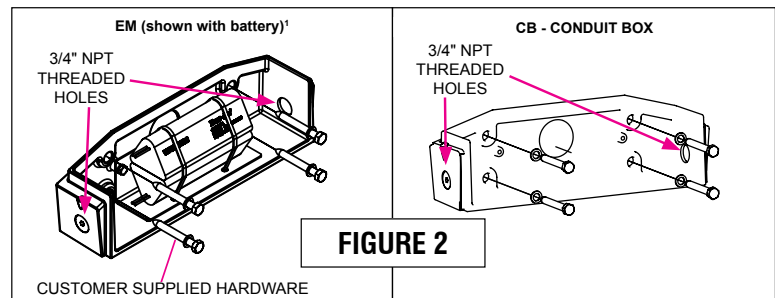
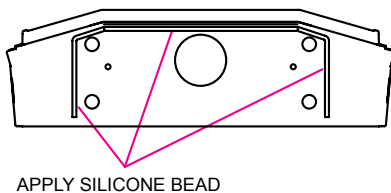

<sup>1</sup>SEE PAGE 2 FOR ADDITIONAL INSTALLATION INSTRUCTIONS

**FIGURE 3**

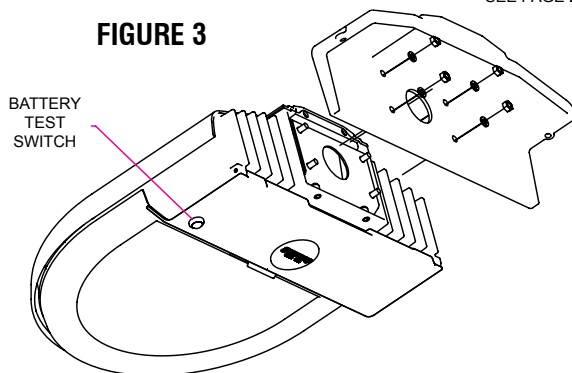

**FIGURE 4**

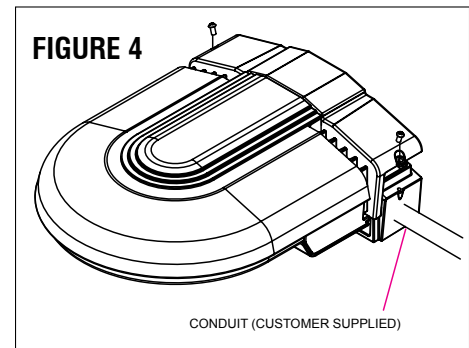

**SternbergLighting**

ESTABLISHED 1923 / EMPLOYEE OWNED

800-621-3376  
555 Lawrence Ave., Roselle, IL 60172  
info@sternberglighting.com  
www.sternberglighting.com

## SL270 WALL SCNCE WITH EMERGENCY LIGHTING (EM) INSTALLATION INSTRUCTIONS

**⚠ WARNING:** BATTERY CONNECTIONS WERE DISCONNECTED PRIOR TO SHIPMENT TO REDUCE SHOCK HAZARD. WITH THE POWER TURNED OFF RECONNECT BATTERY CONNECTORS ONLY AFTER THE FIXTURE HAS BEEN INSTALLED. (SEE FIGURES 1&2)

1. See Solana SL270 wall sconce and emergency driver installation instructions for more information.
2. Do not mount near gas or electric heaters.
3. Equipment should be mounted in locations and heights where it will not readily be subjected to tampering by unauthorized personnel.
4. The use of accessory equipment not recommended by the manufacturer may cause an unsafe condition.
5. Do not use this equipment for other than intended use.

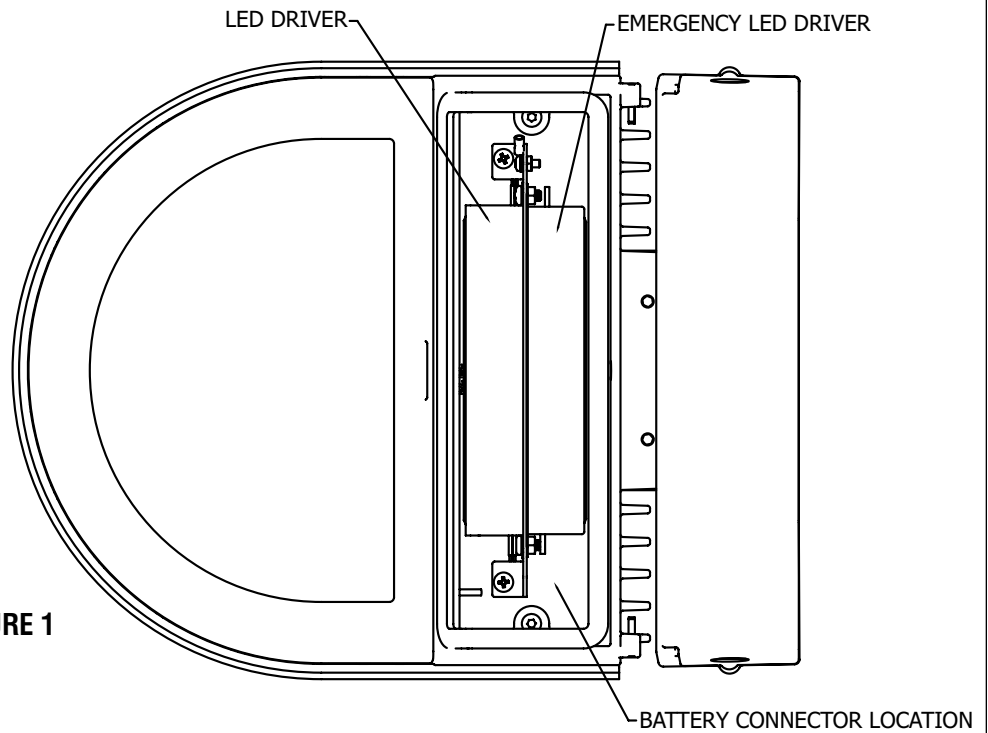

FIGURE 1

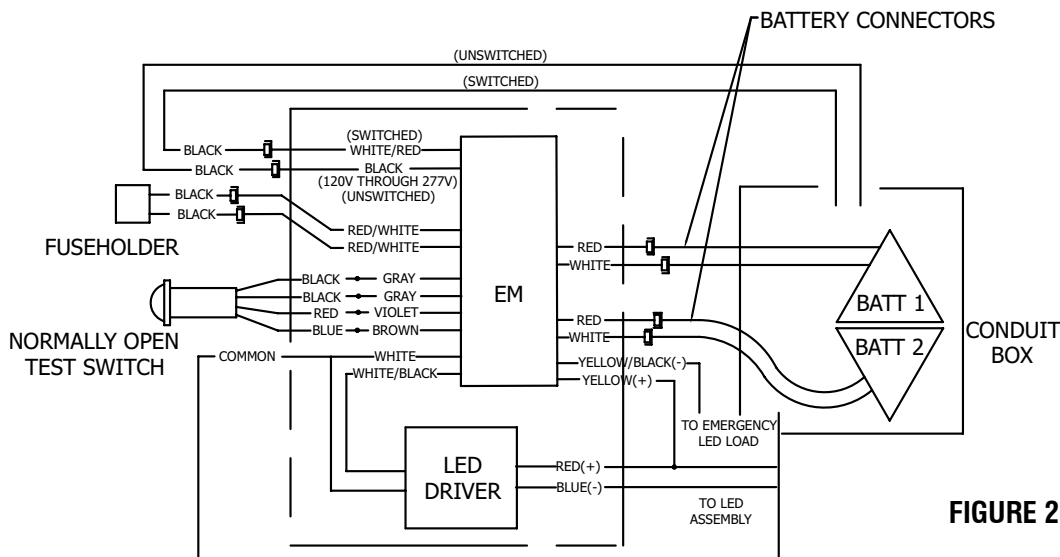

FIGURE 2



**SternbergLighting**

ESTABLISHED 1923 / EMPLOYEE OWNED

800-621-3376  
555 Lawrence Ave., Roselle, IL 60172  
info@sternberglighting.com  
www.sternberglighting.com