

- * INSTALLATION IS REQUIRED BY OTHERS.
- * ALL EDGES TO HAVE 1/4" RADIUS MIN.
- * MANUFACTURING TOLERANCE $\pm 1/4"$.
- * PRODUCT: QS-1BLB
- * QUANTITY: _____
- * CONCRETE COLOR: _____
- * CONCRETE TEXTURE: _____
- * SEALER: STANDARD GLOSS SEALER
- * STD. COLOR & TEXTURE OPTIONS.

Aprox. WT. 296 Lbs.
 (CUSTOMER TO OFFLOAD IF OVER 8000 Lbs.)

Authorized Signature _____ Date _____
 By signing above or stamping this drawing "approved" or
 "no exception taken" authorization is given to Quick Crete
 to produce this drawing as shown within a 1/4" tolerance.

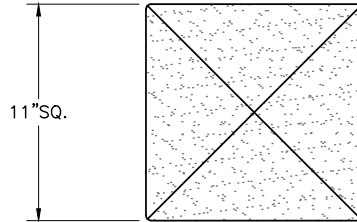

ELEVATION VIEW

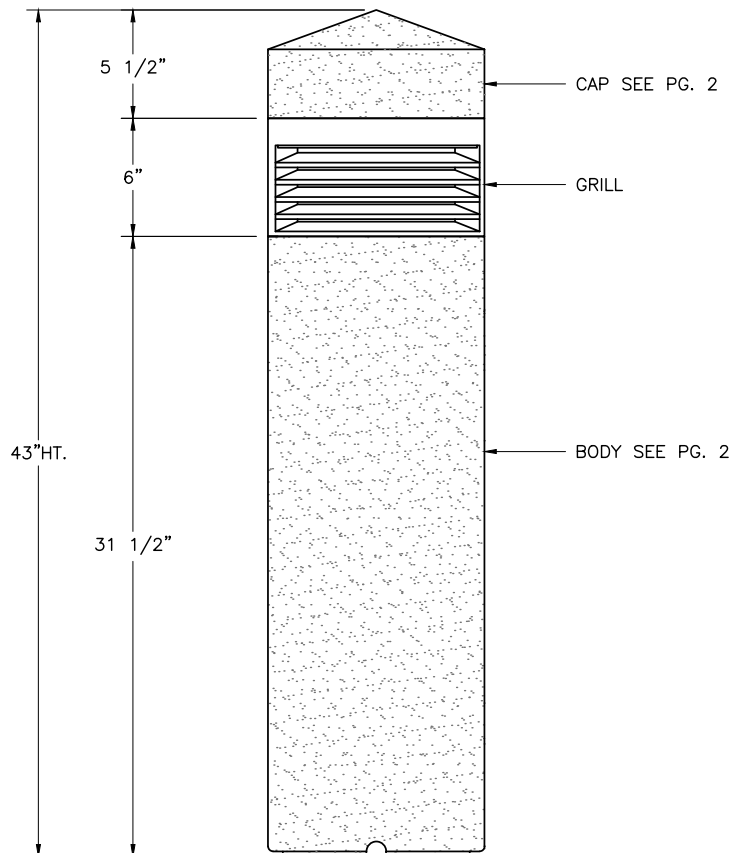

ELEVATION VIEW



QUICK CRETE
 PRODUCTS CORP.
 731 PARKRIDGE AVE.
 P.O. Box 639
 NORCO, CA 92860
 (951) 737-6240 FAX (951) 737-7032
 WWW.QUICKCRETE.COM

PLAN TYPE:	CONSTRUCTION PLAN
PRODUCT:	SQUARE LIGHTED BOLLARD (QS-1BLB)
PROJECT NAME:	

DATE:	3/6/00	FILE NO.	QS1ALB
SCALE:	1 1/4" = 1'	DRAWN BY:	J.U.

SHEET	1
OF	3

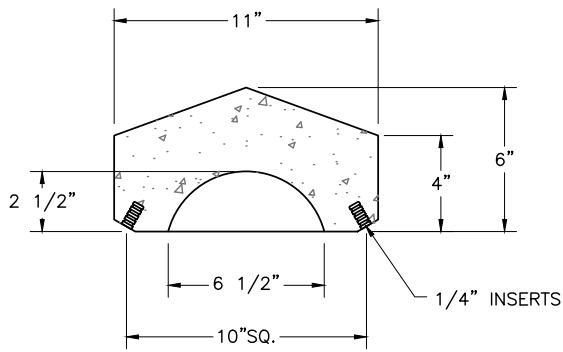

Authorized Signature _____ **Date** _____
 By signing above or stamping this drawing "approved" or "no exception taken" authorization is given to Quick Crete to produce this drawing as shown within a 1/4" tolerance.

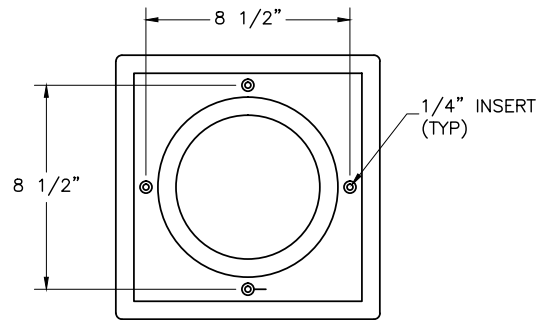

BOLLARD TOP VIEW

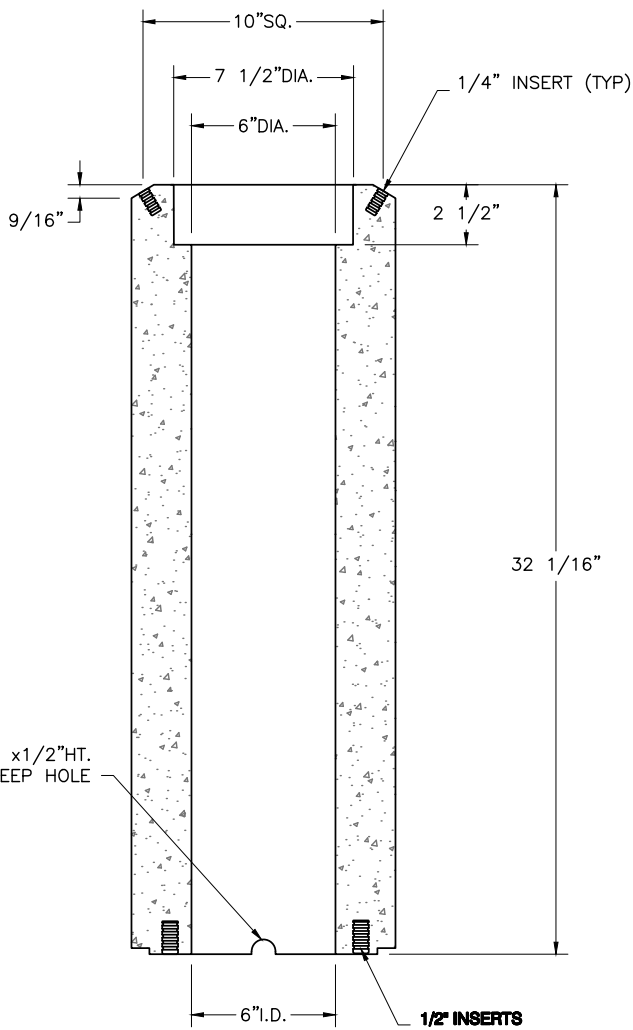

CAP/BODY SECTION VIEW

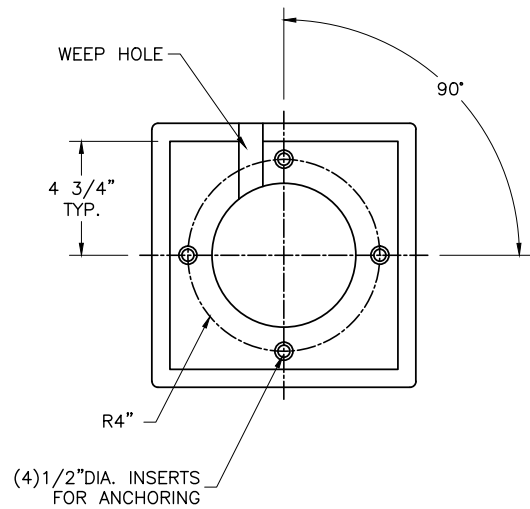

**BOLLARD BOTTOM VIEW
 ANCHOR BOLT PATTERN**

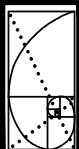

QUICK CRETE
 PRODUCTS CORP.
 731 PARKRIDGE AVE.
 P.O. BOX 639
 NORCO, CA 92860
 (951) 737-6240 FAX (951) 737-7032
 WWW.QUICKCRETE.COM

PLAN TYPE:	CONSTRUCTION PLAN	DATE:	3/6/00	FILE NO.:	QS1BLB-2	SHEET	2
PRODUCT:	SQUARE LIGHTED BOLLARD (QS-1BLB)	SCALE:	1 1/2" = 1'	DRAWN BY:	J.U.	OF	3
PROJECT NAME:							

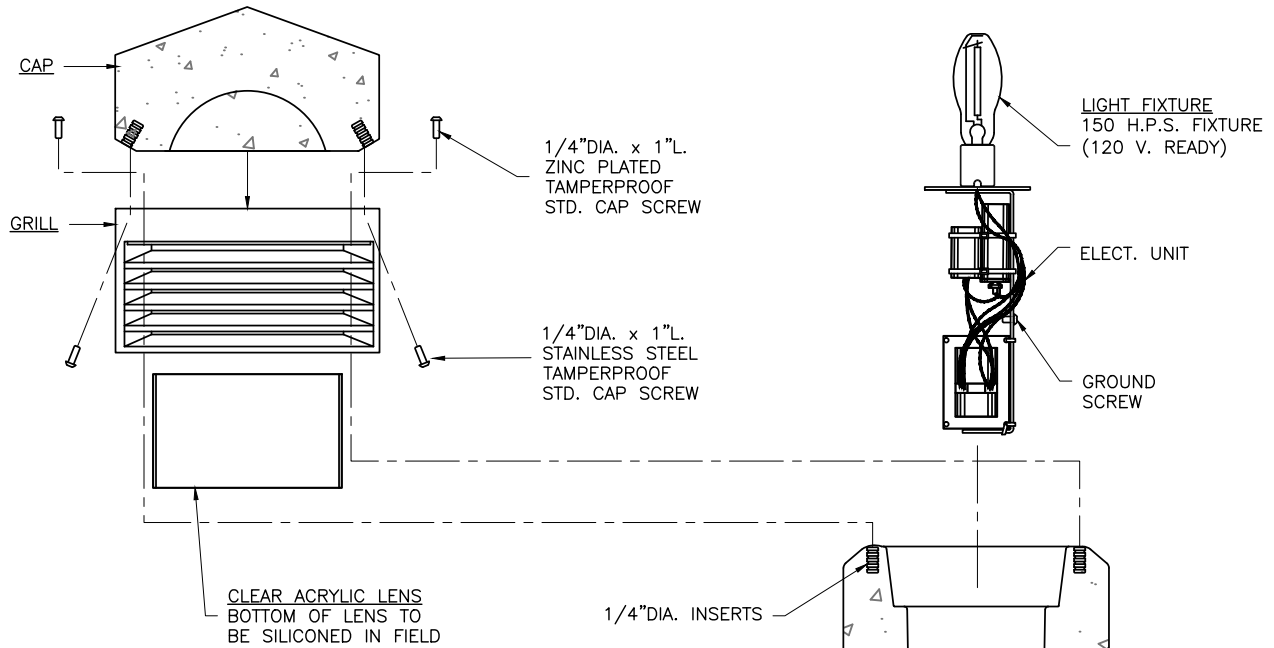

INSTALLATION NOTES:

1. CAST-IN OR CORE DRILL (4) 1-1/2"DIA.x 5"DEEP GROUT POCKETS INTO FOOTING PER ANCHOR BOLT PATTERN (SEE PG. 2)
2. TAKE (4) 1/2"DIA. x 4-1/2"LONG ANCHOR BOLTS AND THREAD INTO (4) 1/2"DIA. THREADED INSERTS, LEAVING 3-1/2" OF THE ANCHOR BOLT EXPOSED.
3. FILL ALL GROUT POCKETS W/ NON-SHRINK GROUT. INSERT BOLLARD W/ ANCHOR BOLTS INTO GROUT POCKETS.
4. FOOTING & INSTALLATION BY OTHERS.

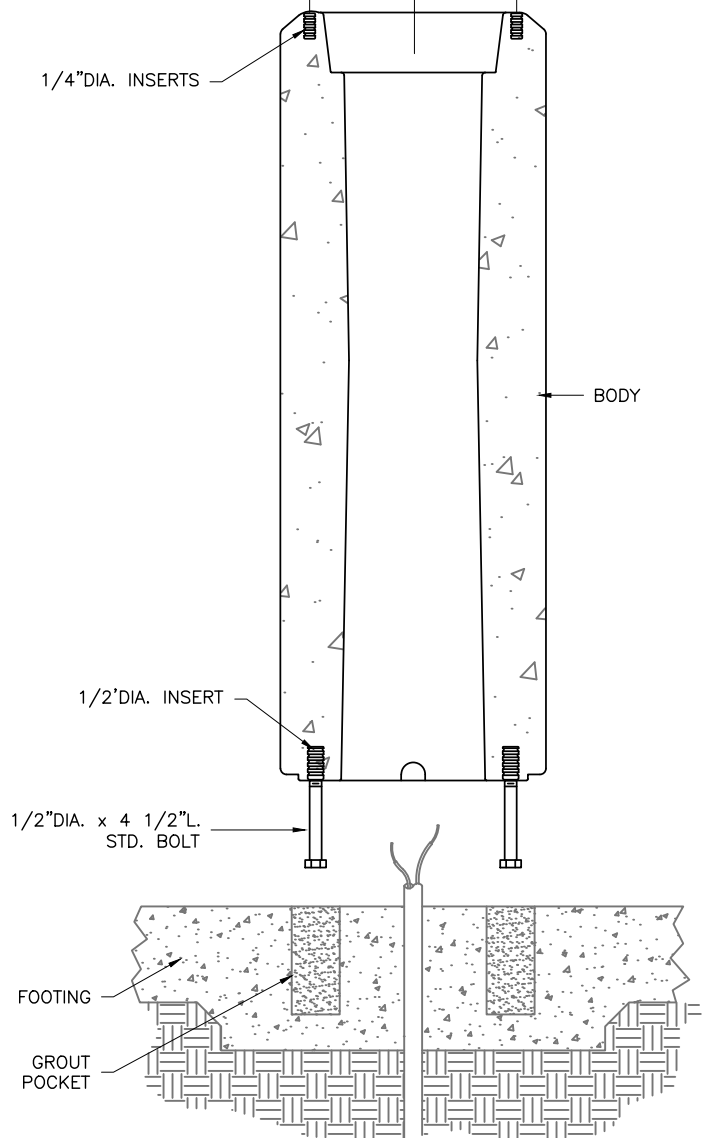

ELEVATION VIEW

HARDWARE LIST	
QTY	TYPE
1	LIGHT GRILL
1	ACRYLIC LENS
1	LIGHT BULB W/ ELECT. UNIT & GROUND SCREW
4	1/4" x 1" ZINC PLATED TAMPER PROOF BOLT
2	1/4" x 1" TAMPER PROOF S.S. BOLT
3	1/2" x 4 1/2" BOLT

QUICK CRETE
 PRODUCTS CORP.
 731 PARKRIDGE AVE.
 P.O. BOX 639
 NORCO, CA 92860
 (951) 737-6240 FAX (951) 737-7032
 WWW.QUICKCRETE.COM

PLAN TYPE: CONSTRUCTION PLAN
 PRODUCT: SQUARE LIGHTED BOLLARD (QS-1BLB)
 PROJECT NAME:

DATE: 3/6/00
 SCALE: 1 1/2" = 1'
 FILE NO. QS1ALB-3
 DRAWN BY: J.U.

SHEET 3 OF 3