



Forever Bright

SPECIFICATION FEATURES



Model: **SPJ08-04**
Finish: Aged Brass

- Finish:** Our naturally etched finishes will withstand the test of time. All finishes are individually treated insuring consistency. Our meticulous application results in a fixture that truly becomes "a one of a kind".
- Electrical:** Available in 8-15V
- Labels:** ETL Standard Wet Label
C-ETL

Tulip Style Path Lights

DESCRIPTION

- Model#:** SPJ08-04
- Material:** Solid Brass
- Electrical:** 8-15V
- Engine:** FB-2W-CYL-TA16
- Lumens:** 150
- Color Temp:** 2700 k
- Mounting:** 1/2" NPT. Dual Fin Spike Incl.
- LED:** Nichia

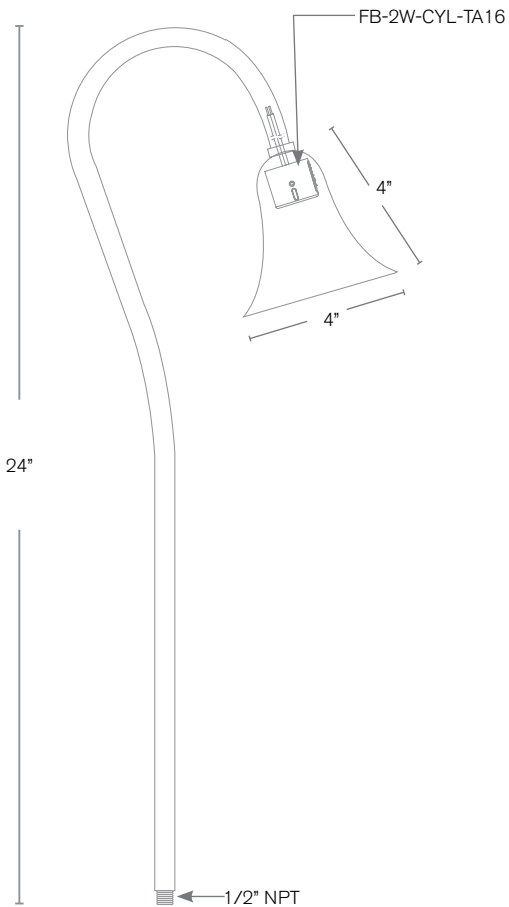

Wet Listed



ORDERING INFORMATION

Model#	Finishes	Wattage	Lumens	Color Temp.	Electrical
SPJ08-04	AG	2W	150	2700K	8-15V

- V = Verde
- M = Moss
- AG = Aged Brass
- MBR = Matte Bronze
- RC = Raw Copper
- GM = Gun Metal
- B = Black
- R = Rusty
- PVDP = PVD Polished
- PVDS = PVD Satin
- 2W
- 150
- 160
- 170
- 2700K
- 4000K
- 5000K
- 8-15V