

PRODUCT: **SPJ-PCL-QR-1ALB**

WEIGHT: 286 lbs
(CUSTOMER TO OFFLOAD IF OVER 6000 Lbs.)

QUANTITY: _____

- CONCRETE COLOR:
- QUAIL HILL RED
 - NATURAL
 - MISSION WHITE
 - LATTE
 - HARVEST
 - FRENCH GREY
 - BUNGALOW
 - ADOBE TAUPE
 - CUSTOM COLOR

- CONCRETE TEXTURE:
- CRAFTSMANS ETCH
 - STRATA

SEALER: STANDARD SEALER

GENERAL PRODUCT NOTES:
 E = EXPOSED FINISHED SURFACE
 INSTALLATION IS REQUIRED BY OTHERS.
 ALL EDGES TO BE EASED.
 MANUFACTURING TOLERANCE $\pm 1/4"$.

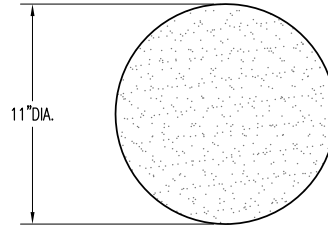

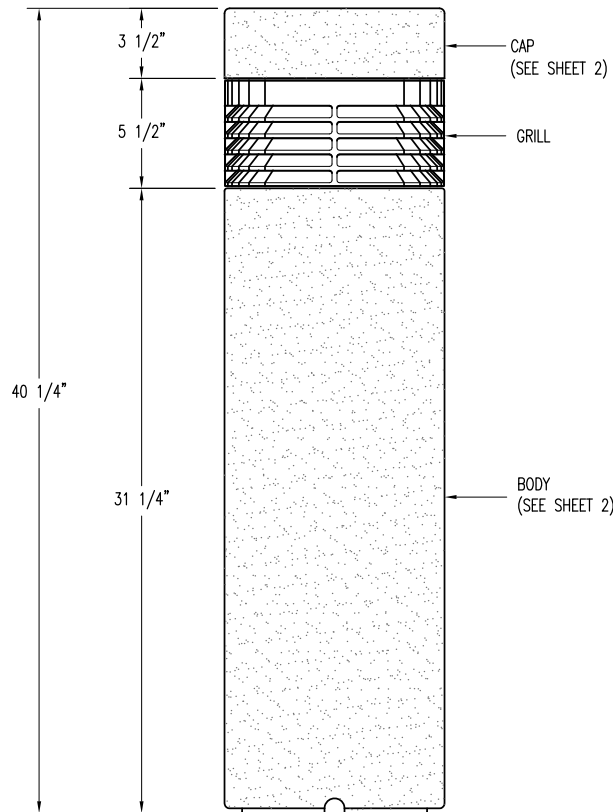

PLAN VIEW

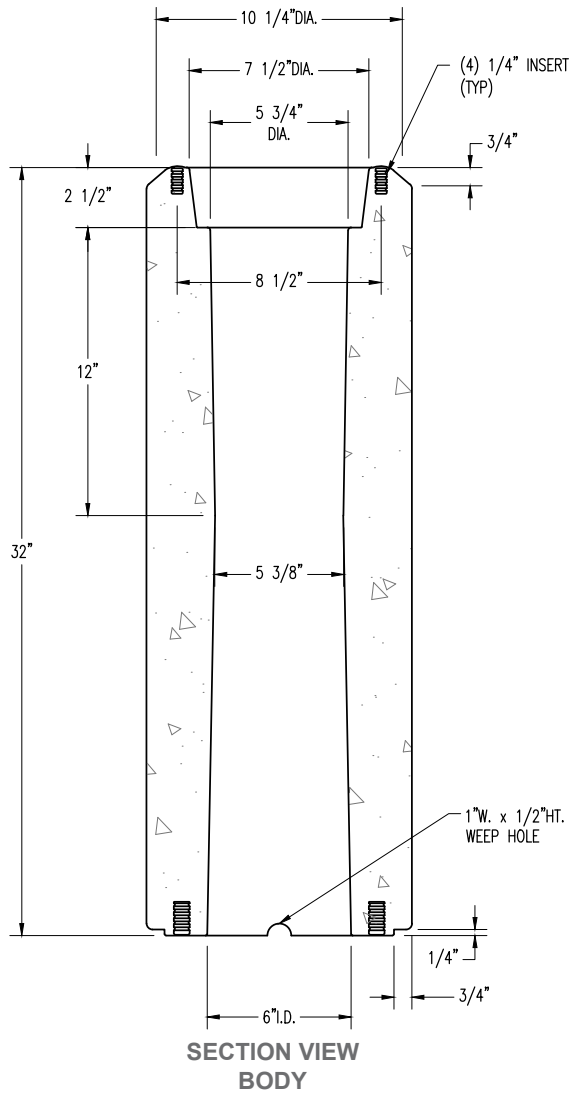
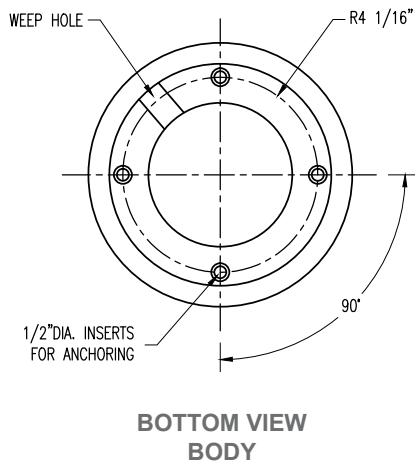
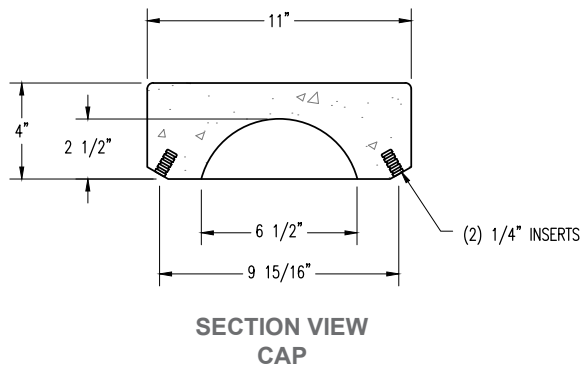

ELEVATION VIEW

 ARCHITECTURAL LANDSCAPE & OUTDOOR LIGHTING	PLAN TYPE	CONSTRUCTION PLAN	DATE	2/6/17	FILE NO.	070_QR_1ALB_1o3	SHEET	X
	PRODUCT	SPJ-PCL-QR-1ALB BOLLARD ROUND LIGHTED	SCALE	1 1/4" = 1'	DRAWN BY:	-	OF	X
	PROJECT NAME	-	PC. NO.	-	QC ITEM NO.	-		



 <p>ARCHITECTURAL LANDSCAPE & OUTDOOR LIGHTING</p>	PLAN TYPE	CONSTRUCTION PLAN	DATE	FILE NO.	SHEET
	PRODUCT	SPJ-PCL-QR-1ALB BOLLARD ROUND LIGHTED	2/6/17	070_QR_1ALB_2o3	X
	PROJECT NAME	-	SCALE	DRAWN BY:	OF
			1 1/2" = 1'	-	X
			PC. NO.	QC ITEM NO.	
			-	-	

INSTALLATION NOTES:

1. CAST-IN OR CORE DRILL (4) 1-1/2"DIA. x 5"DEEP GROUT POCKETS INTO FOOTING PER ANCHOR BOLT PATTERN (SEE SHEET 2).
2. TAKE (4) 1/2"DIA. x 4-1/2"LONG ANCHOR BOLTS AND THREAD INTO (3) 1/2"DIA. THREADED INSERTS, LEAVING 3-1/2" OF THE ANCHOR BOLT EXPOSED.
3. FILL ALL GROUT POCKETS W/ NON-SHRINK GROUT. INSERT BOLLARD W/ ANCHOR BOLTS INTO GROUT POCKETS.
4. FOOTING & INSTALLATION BY OTHERS.

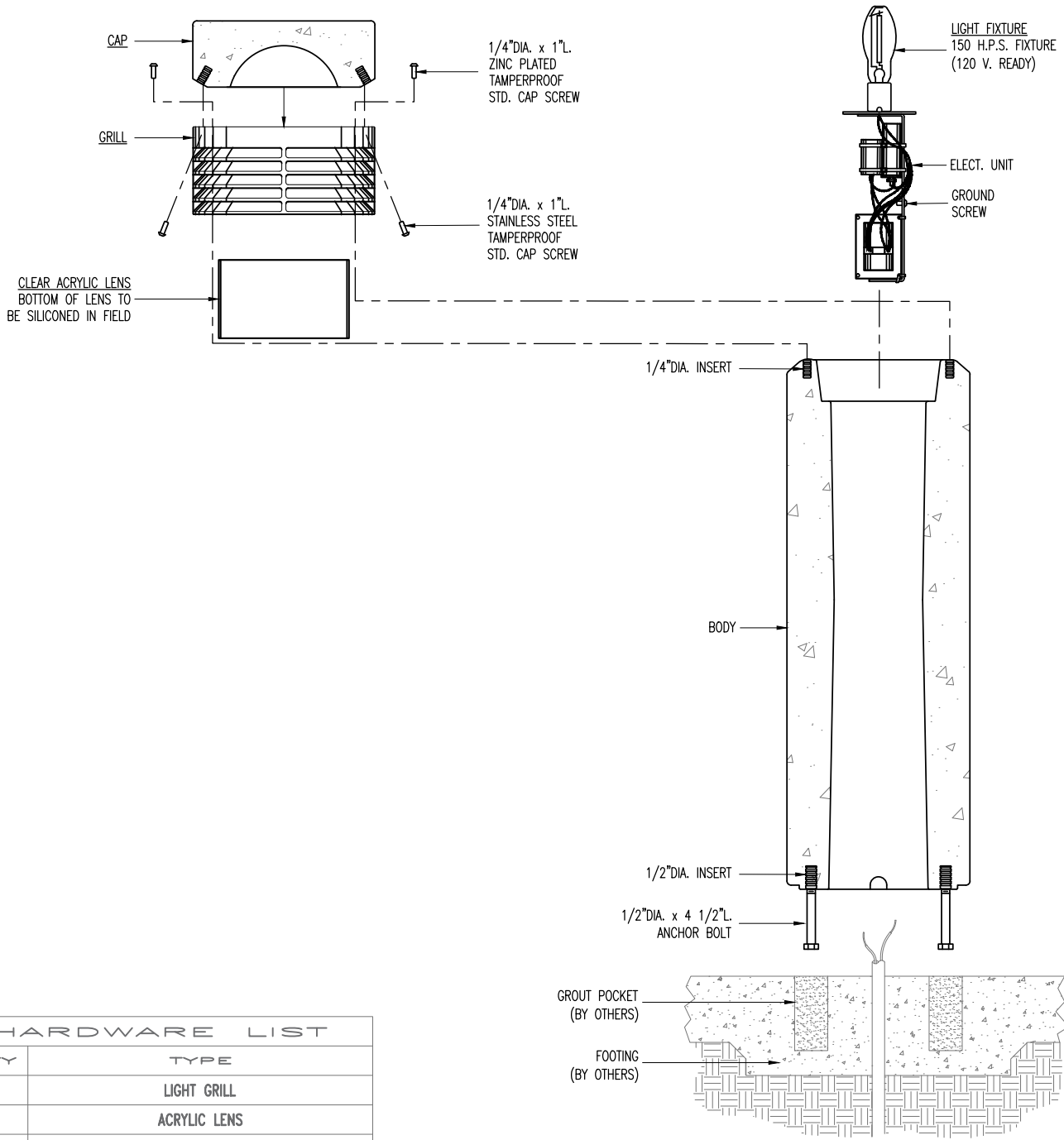

ELEVATION VIEW

HARDWARE LIST	
QTY	TYPE
1	LIGHT GRILL
1	ACRYLIC LENS
1	LIGHT BULB W/ELECT. UNIT & GROUND SCREW
4	1/4" X 1" ZINC PLATED TAMPER PROOF BOLT
2	1/4" X 1" TAMPER PROOF S.S. BOLT
3	1/2"DIA. X 4 1/2"L. BOLTS

	PLAN TYPE	CONSTRUCTION PLAN	DATE	2/6/17	FILE NO.	070_QR_1ALB_3o3	SHEET	X
	PRODUCT	SPJ-PCL-QR-1ALB BOLLARD ROUND LIGHTED	SCALE	1 1/4" = 1'	DRAWN BY:	-	OF	-
	PROJECT NAME	-	PC. NO.	-	QC ITEM NO.	-		X