



Forever Bright

SPECIFICATION FEATURES

Finish: Our naturally etched finishes will withstand the test of time. All finishes are individually treated insuring consistency. Our meticulous application results in a fixture that truly becomes "a one of a kind".



Model: **SPJ-MB2**
Finish: Powdercoat Bronze

Mailbox

DESCRIPTION

Model#: SPJ-MB2
Finish: Powdercoat Bronze
Material: Aluminum
Mounting: Concrete Footing

Mail Plates

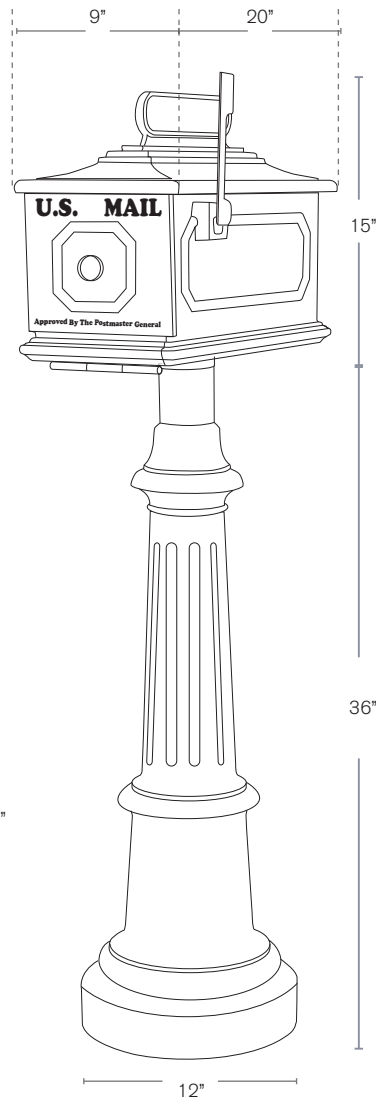
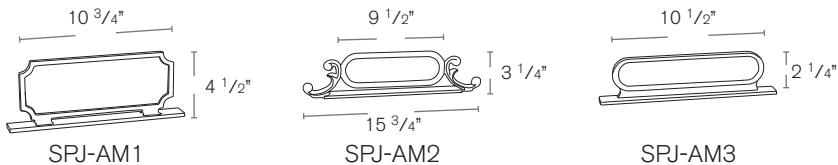

Wet Listed



ORDERING INFORMATION

Model#	Finishes	Plate	Numbers
SPJ-MB2	PCBR	SPJ-AM3	-

PCBR = Powdercoat Bronze
PCB = Powdercoat Black
PCW = Powdercoat White
CPC = Custom Powdercoat

SPJ-AM1
SPJ-AM2
SPJ-AM3