



# Forever Bright

## SPECIFICATION FEATURES

**Finish:** Our naturally etched finishes will withstand the test of time. All finishes are individually treated insuring consistency. Our meticulous application results in a fixture that truly becomes "a one of a kind".

**Electrical:** Available in 9-15v

**Labels:** ETL Standard Wet Label  
C-ETL



Model: **FB-2WREC-TA-5-B-2700K**

## DESCRIPTION

**Model:** FB-2WREC-TA-5-B-2700K  
**Electrical:** 9-15V  
**Lamp:** 2W-FB-LED  
**Color Temp:** 2700K  
**Size:** 6"W x 3/4"H x 3/8" Depth

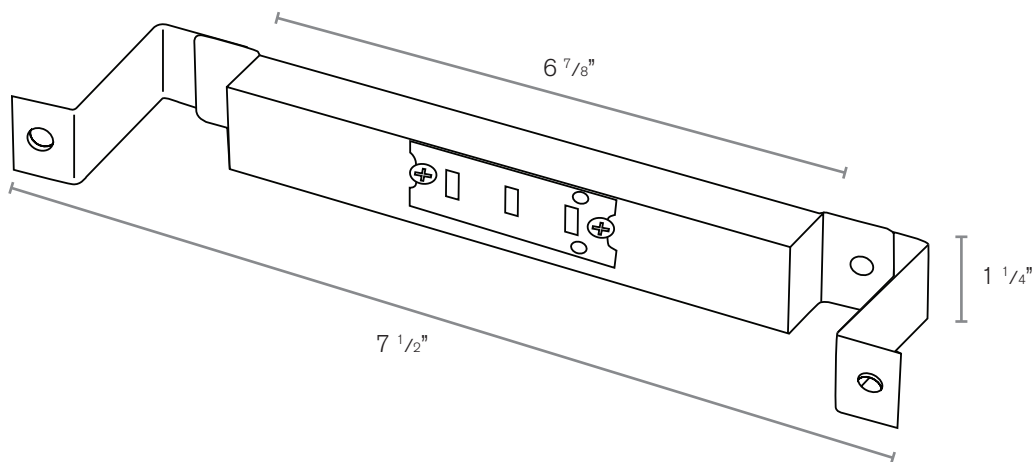

## ORDERING INFORMATION

### Model#

**FB-2WREC-TA-5-B-2700K**

FB-2WREC-TA-5-B-2700K

### Finishes

V = Verde	GM = Gun Metal
M = Moss	B = Black
AG = Aged Brass	R = Rusty
MBR = Matte Bronze	PVDP = PVD Polished
SB = Satin Brass	PVDS = PVD Satin

### Color Temp.

**2700K**

2750K  
3900K  
6000K

### Electrical

**9-15V**

9-15V

8

7

6

5

4

3

2

1

PROPRIETARY AND CONFIDENTIAL  
 THIS DOCUMENT CONTAINS CONFIDENTIAL AND PROPRIETARY INFORMATION OF PERMLIGHT AND SHALL NOT BE REPRODUCED OR DISCLOSED, OR USED IN THE MANUFACTURE, USE OR SALE OF ANY ITEM WITHOUT THE PRIOR WRITTEN PERMISSION OF PERMLIGHT - TUSTIN.

REVISIONS					
ZONE	REV.	DESCRIPTION	DATE	ECO NO.	APPROVED
	X01	PROTOTYPE	7/3/2012		F. LYNCH

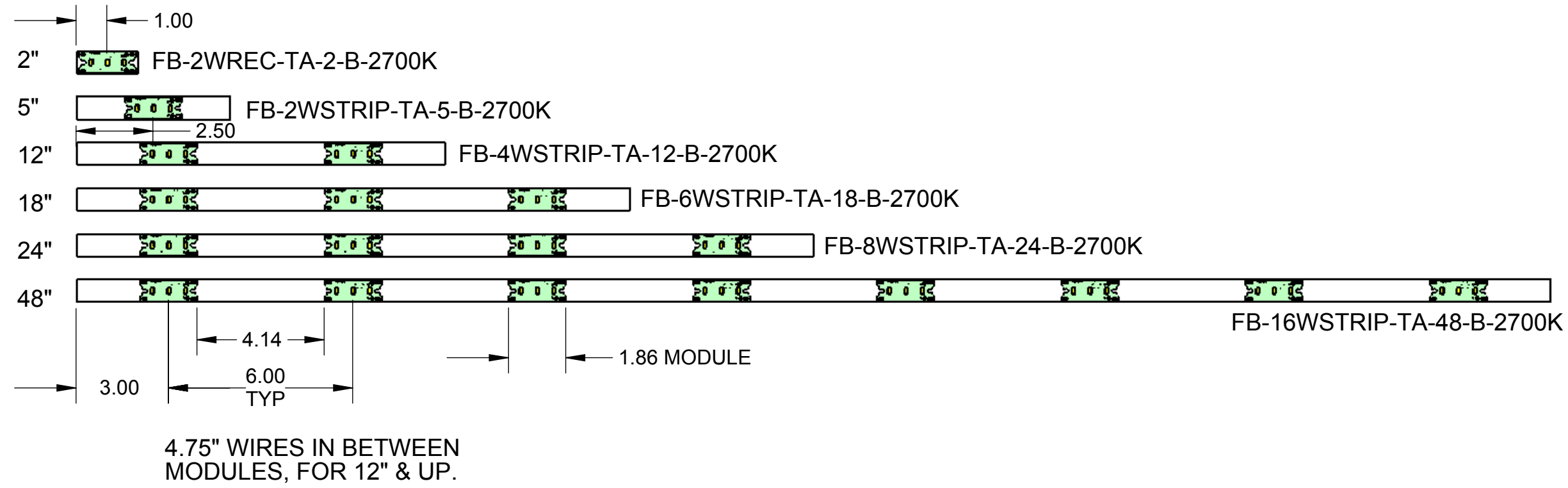

<b>DIMENSIONS ARE IN INCHES [mm]</b> TOLERANCES (UNLESS OTHERWISE SPECIFIED) XX ± .01 [.25] XXX ± .005 [.125] Ø's ± .005 [.125] ANGLE ± .5°	CAD GENERATED DRAWING BY SOLIDWORKS DO NOT MANUALLY UPDATE		<b>PERMLIGHT PRODUCTS INC.</b> 422 West 6th Street, Tustin, CA 92780 Ph: (714) 508-0729 Fax: (714) 508-0920
	APPROVALS DRAWN K. KOHAN CHECKED F. LYNCH ENGINEER	DATE 7/3/12 7/3/12	
	MATERIAL FINISH	APPROVED INTERPRET GEOMETRIC TOLERANCING PER ANSI Y14.5M	SIZE DWG. NO. <b>B</b>
	SCALE: 1:4 THIRD ANGLE PROJECTION		REV. SHEET 1 OF 1

8

7

6

5

4

3

2

1

Model File: SPJ LINEAR MATRIX ASSY