

INSTALLATION INSTRUCTIONS

ANY ISSUES WITH INSTALLATION REQUIRES IMMEDIATE CALLS TO SHAPER

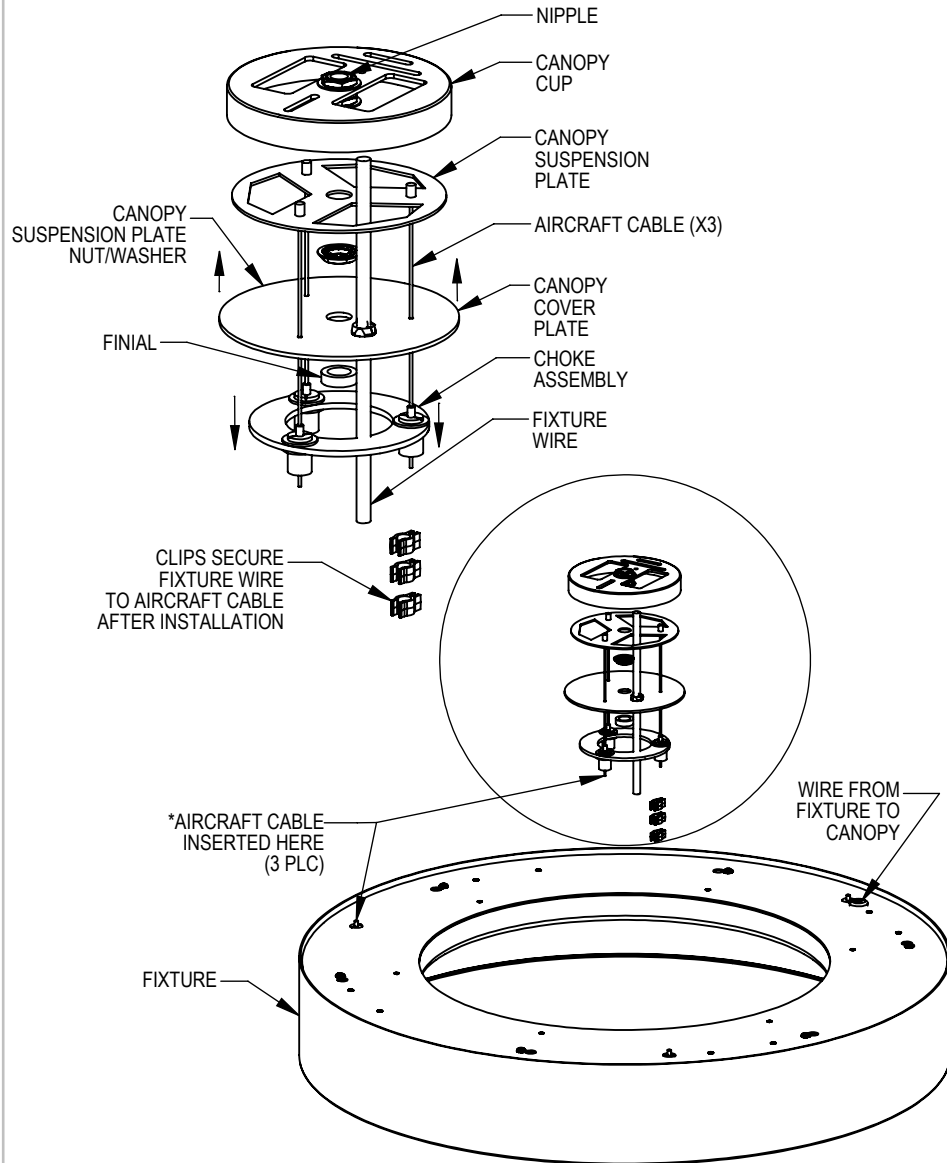

**IF AIRCRAFT CABLE GRIPPER IS REMOVED FOR SERVICING, TORQUE TO 45 IN-LBS*

NOTICE:

- For proper installation, a qualified electrician should install this product.
- Before installation of any luminaire onto an electrical junction box, be sure to disconnect power.
- This luminaire must be wired and grounded in accordance with the National Electrical Code, local codes, and ordinances.
- Wire supply connections must be made with UL approved connectors.
- Confirm that luminaire and supply voltage are the same.
- Junction box provided by others with means of supporting minimum 50 lbs.
- Supply wire to be rated for 90 °C.
- This fixture is UL listed for dry or damp location only.

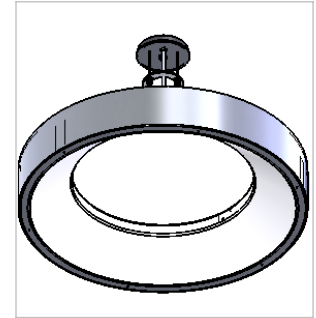

845-XX

CAUTION:

- FIXTURE WEIGHT APPROXIMATELY 10 LBS.
- CONTRACTOR REQUIRED TO PROVIDE APPROPRIATE STRUCTURAL SUPPORT FOR FIXTURE TO MEET LOCAL CODE REQUIREMENTS.
- AVOID INSTALLING THIS FIXTURE NEAR AREAS OF HIGH AIR MOVEMENT (HVAC VENTS, DOORWAY, WINDOWS) TO MINIMIZE FIXTURE SWAY.
- ALLOW AT LEAST 1" OF AIRCRAFT CABLE TO FEED THRU CABLE GRIPPER. DO NOT FEED EXCESS AIRCRAFT CABLE INTO FIXTURE OR JUNCTION BOX WHERE ELECTRICAL WIRES ARE LOCATED.
- LEVEL FIXTURE.
- EXERCISE SPECIAL CARE AND SAFETY WHILE INSTALLING AND SERVICING LUMINAIRE.
- USE OF SOFT GLOVES AND PADDED MATERIALS ARE RECOMMENDED DURING HANDLING TO AVOID MARRING THE FINISH.
- COMPONENTS MAY BE CLEANED WITH SOFT DAMP OR DRY CLOTH.

INSTRUCTIONS:

1. Disconnect electrical lighting circuit (at breaker panel).
2. Secure Canopy Cup to junction box with (2) #8 screws provided.
3. Feed aircraft cable thru Canopy Suspension Plate, Cover Plate, and Choke assembly.
4. Slide Choke assembly down aircraft cable to allow removal of Canopy Cover Plate.
5. Make sure Canopy Suspension Plate is well secured to nipple in Canopy Cup with nut.
6. Do not install Canopy Cover Plate until wiring is complete.
7. Install Fixture to Canopy assembly by inserting aircraft cable thru cable grippers on top of Fixture.
8. Wiring Fixture to source AC wiring, using UL listed wire connectors: connect the neutral (white) wire to the supply neutral, connect the luminaire line wire (black) to the supply line wire, connect the ground (green) wire to the supply ground.
9. Wiring Fixture 0-10V dimming to source dimming wiring, using UL listed wire connectors: connect the fixture blue wire to the dimmer violet wire, connect the fixture brown to the dimmer gray wire, if driver thermal sensing is used, connect fixture orange wire to thermal sensing device.
10. Inspect wire connections before installing Canopy Cover Plate.
12. Install Canopy Cover Plate with Finial.
13. Restore power to lighting circuit and test installation.