

SB SPOKE BRACKET SPECIFICATIONS					
CATALOG #	BRACKET TENON	BRACKET EPA (SQ. FT.)	MAX. LUMINAIRE WT. (LBS)	MAX. LUMINAIRE EPA (SQ. FT.)	SHIP WEIGHT (LBS)
SB-29	2 @ 90	0.4	125	6.0	11

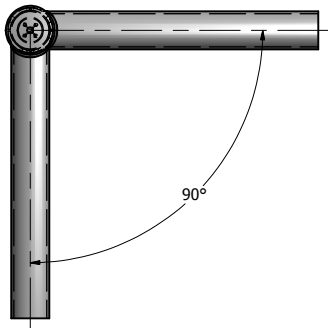

VIEW A-A
SB-29 TOP VIEW DETAIL

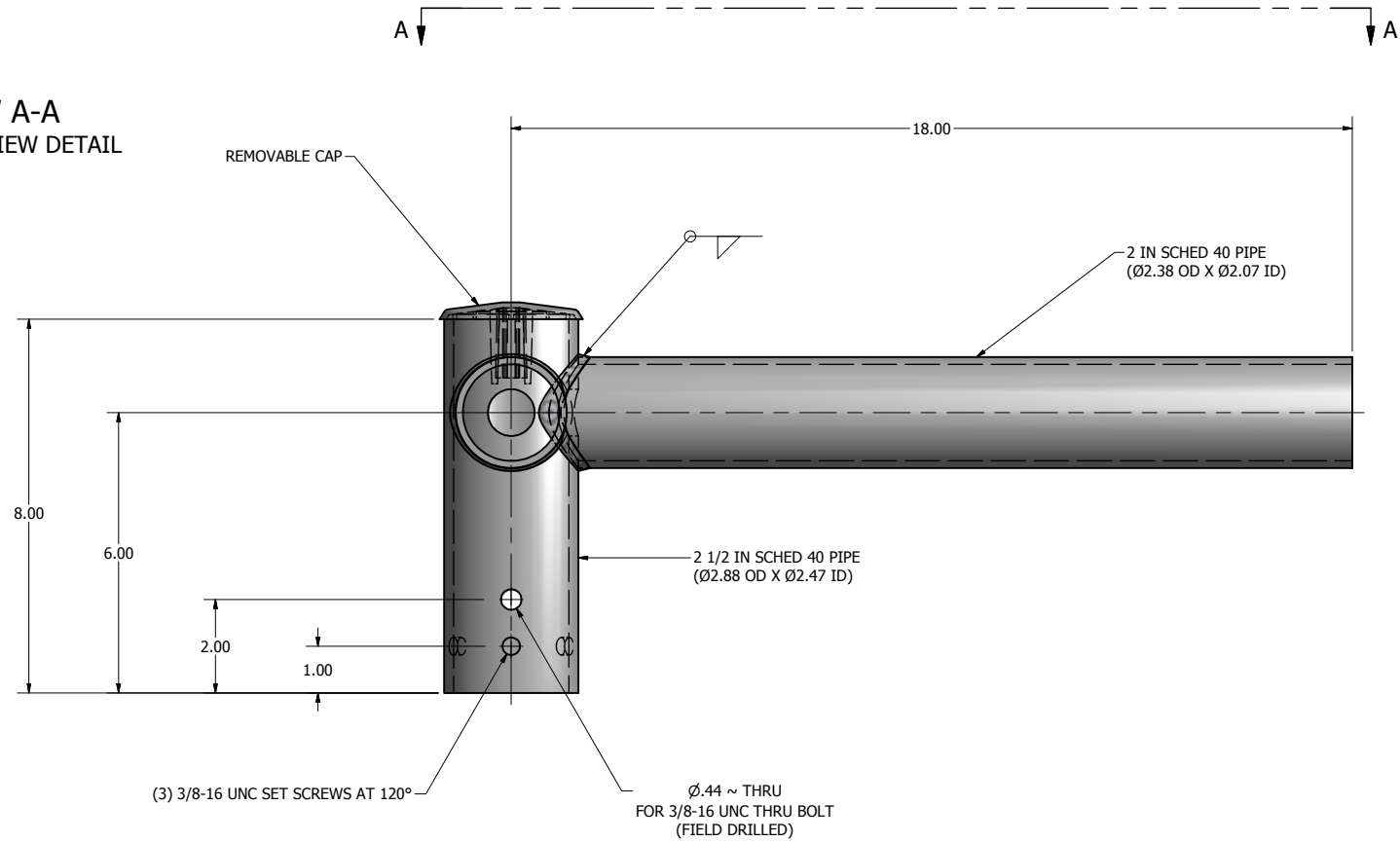

NOTE: SB SERIES POLE TOP MOUNTING BRACKETS SLIP FIT 2 IN PIPE TENONS (Ø2.38 OD). BRACKET ARMS ARE CONSTRUCTED OF 2 IN PIPE. BRACKETS ARE FINISHED TO MATCH POLE.

BRACKETS CATALOGED ARE CONSTRUCTED OF STEEL AND ARE DESIGNED FOR USE WITH STEEL OR ALUMINUM POLES. IF ALUMINUM BRACKETS ARE REQUIRED FOR ALUMINUM POLES, CONTACT YOUR REPRESENTATIVE.



 P.O. Box 340
 Eastpointe, MI 48021
 P: (586) 771-4610 | F: (586) 771-5527
 www.lytepoles.com
a DWM company

DRAWN: M. HARVALA	2/16/2015
CHECKED	
REVISION:	DATE:
APPROVED:	
QUOTE:	
S.O.#	
REF:	SCALE: NONE

SOME GEOGRAPHICAL AREAS HAVE SPECIAL WIND CONDITIONS THAT CAN CREATE WIND INDUCED VIBRATIONS CAUSING A FATIGUE PROBLEM. NO METHOD HAS YET BEEN FOUND FOR PREDICTING DESTRUCTIVE LIGHTING POLE VIBRATION. THESE CONDITIONS ARE UNIQUE AND CANNOT BE GUARANTEED AGAINST, AND ARE THE RESPONSIBILITY OF A LOCAL SITE ENGINEER.		
TITLE:		
CATALOG:		
DWG NO: SB-29	SIZE C	SHEET 1 OF 1

