

WIRE ACCESS HOLE

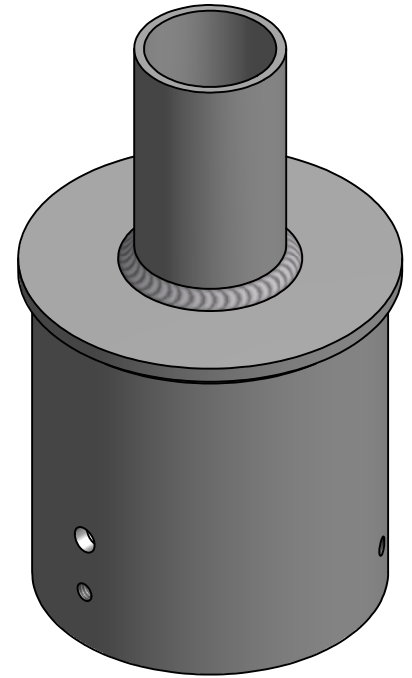

PTR-5RD-T2-STD

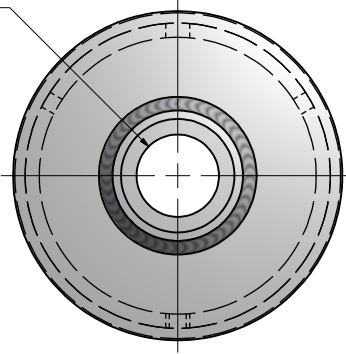
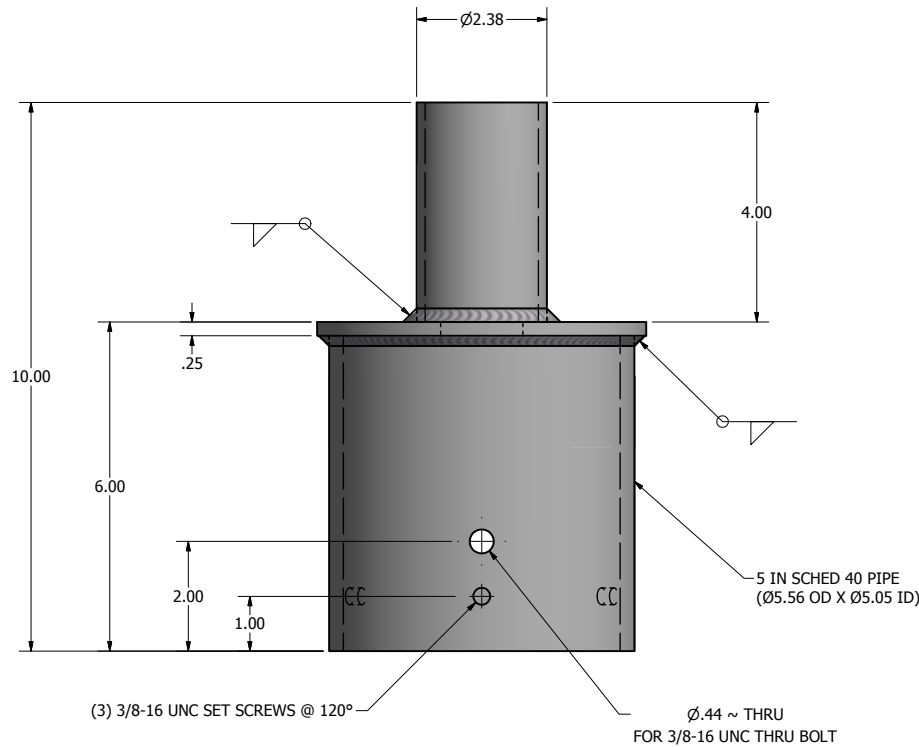

- TENON OPTIONS**
- T2- $\varnothing 2.38$ OD X 4.00 LG
 - T3- $\varnothing 3.00$ OD X 5.00 LG
 - T4- $\varnothing 4.00$ OD X 6.00 LG

NOTE: OTHER TENON SIZES AVAILABLE UPON REQUEST, CONTACT FACTORY FOR ADDITIONAL SIZES.

FINISH: BRACKET SHALL BE POLYESTER POWDER COAT FINISH IN A STANDARD COLOR.

lyte poles
 a DWM company

P.O. Box 340
 Eastpointe, MI 48021
 P: (586) 771-4610 | F: (586) 771-5527
 www.lytepoles.com

DRAWN: M. HARVALA	2/16/2015
CHECKED	
REVISION:	DATE:
APPROVED:	
QUOTE:	
S.O.#	
REF:	SCALE: NONE

SOME GEOGRAPHICAL AREAS HAVE SPECIAL WIND CONDITIONS THAT CAN CREATE WIND INDUCED VIBRATIONS CAUSING A FATIGUE PROBLEM. NO METHOD HAS YET BEEN FOUND FOR PREDICTING DESTRUCTIVE LIGHTING POLE VIBRATION. THESE CONDITIONS ARE UNIQUE AND CANNOT BE GUARANTEED AGAINST, AND ARE THE RESPONSIBILITY OF A LOCAL SITE ENGINEER.	
TITLE:	
CATALOG:	
DWG NO: PTR-5RD-T2-STD	SIZE C
SHEET 1 OF 1	

