

PCB FLOODLIGHT BRACKETS			
CATALOG #	# OF FLOODLIGHTS	POLE SIZING	LUMINAIRE WEIGHT (PER ARM)
PCB3-4	4	5.00-9.00 DIA	50 LBS. MAX

- (8) 5/8-11 UNC X 3.00" THREADED ROD
- (16) 5/8 SAE FLAT WASHER
- (16) 5/8 LOCK WASHER
- (16) 5/8-11 UNC HEX JAM NUT

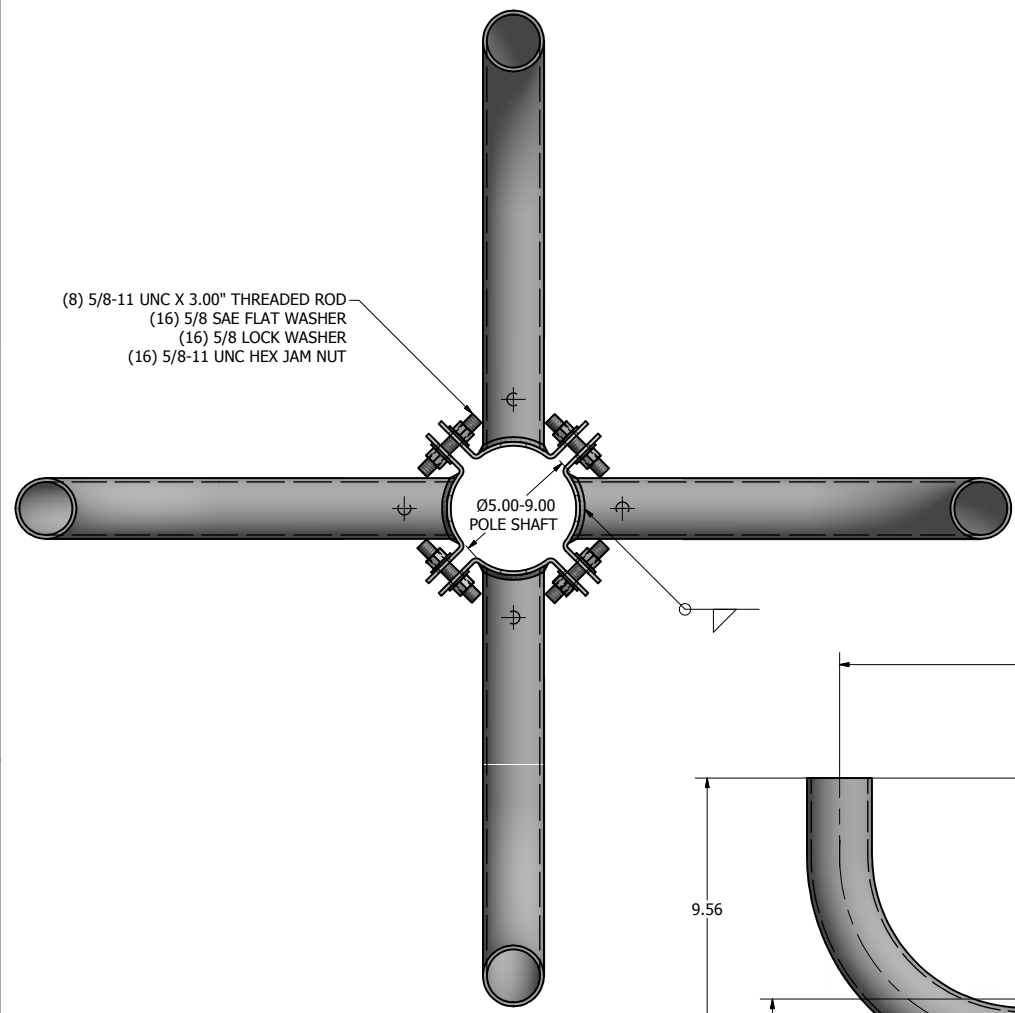

TOP VIEW

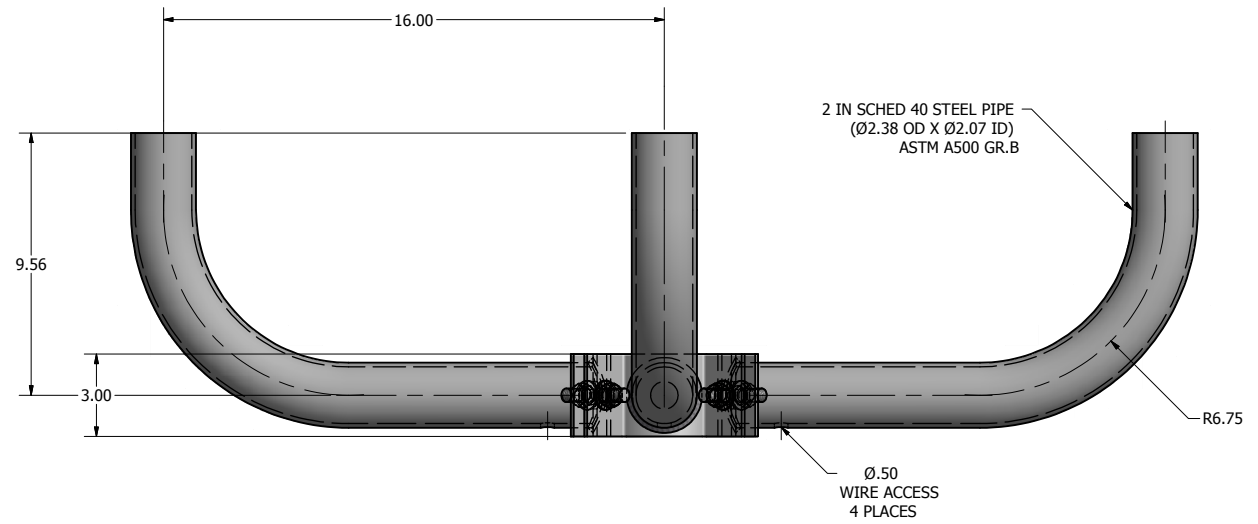

NOTE: LUMINAIRE WEIGHT PER ARM 50 LBS MAX.
FINISH: BRACKET SHALL BE POLYESTER POWDER COAT FINISH IN A STANDARD COLOR OR HOT DIPPED GALVANIZED FINISH PER ASTM A123 SPECIFICATIONS.

lyte poles
 a DWM company

P.O. Box 340
 Eastpointe, MI 48021
 P: (586) 771-4610 | F: (586) 771-5527
 www.lytepoles.com

DRAWN: L. GRUNIS	1/31/2017
CHECKED	
REVISION:	DATE:
APPROVED:	
QUOTE:	
S.O.#	
REF:	SCALE: NONE

SOME GEOGRAPHICAL AREAS HAVE SPECIAL WIND CONDITIONS THAT CAN CREATE WIND INDUCED VIBRATIONS CAUSING A FATIGUE PROBLEM. NO METHOD HAS YET BEEN FOUND FOR PREDICTING DESTRUCTIVE LIGHTING POLE VIBRATION. THESE CONDITIONS ARE UNIQUE AND CANNOT BE GUARANTEED AGAINST, AND ARE THE RESPONSIBILITY OF A LOCAL SITE ENGINEER.		
TITLE:		
CATALOG:		
DWG NO: PCB3-4	SIZE C	SHEET 1 OF 1

