

The GE/Lightech LED-18DC-700 is an 18 Watt electronic, constant current, remote driver available to power LuxR series version fixtures in the USA market. It is ELV dimmable (trailing edge).

For exterior use, it is highly recommended to install this in a weatherproof box, available as an option from LuxR. The PC-17-02 weatherproof box is a requirement for UL compliance.

When this driver is used as a remote power supply, SERIES WIRING is required to connect the fixtures. Please refer to the wiring diagram overleaf.

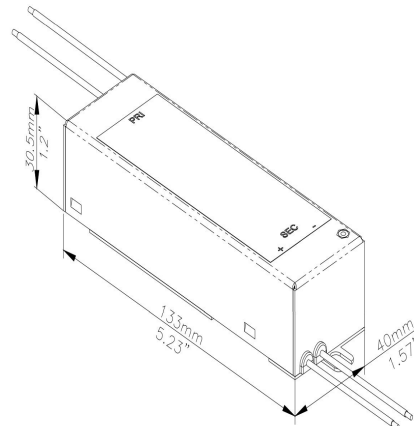

SPECIFICATIONS



Input Voltage	120-277Vac 50-60Hz
Output Voltage	4V-26V dc
Output Current	700mA
Wattage	18 Watt
Temperature range	-25...+50°C, max 90°C
Dimensions	133x40x30.5mm (5.23"x1.57"x1.2")
Standards	IP67, CSA, UL Recognized
Ordering Code	LED-18DC-700.
Ingress Protection Rating	IP67
Compatibility	Modux: Modux 2 or 4 products
Warranty	Warranty 5 years

