

# XBVR LED BOLLARD SERIES INSTALLATION INSTRUCTIONS

- WARNING:** BEFORE PROCEEDING, READ ALL INSTRUCTIONS CAREFULLY TO INSURE PROPER AND SAFE INSTALLATION.
- WARNING:** RISK OF FIRE OR ELECTRICAL SHOCK. DISCONNECT POWER BEFORE INSTALLING OR SERVICING.
- WARNING:** RISK OF ELECTRICAL SHOCK.
- WARNING:** ALL WIRING TO BE PERFORMED PER NATIONAL ELECTRICAL CODE AND LOCAL CODE BY A QUALIFIED ELECTRICIAN.
- WARNING:** VERIFY THAT SITE INPUT VOLTAGE MATCHS DRIVER VOLTAGE RATING BEFORE WIRING.
- WARNING:** FAILURE TO FOLLOW THE INSTRUCTIONS COULD RESULT IN DAMAGE TO THE PRODUCT & VOID ALL WARRANTIES!
- NOTE:** MAKE CERTAIN ALL UNUSED LEADS ARE CAPPED INDIVIDUALLY! FAILURE TO DO SO MAY SHORT OUT LUMINAIRE AND VOID WARRANTY!
- NOTE:** KEEP THESE INSTRUCTIONS FOR FUTURE REFERENCE.

**INSTALLATION:** TOOLS REQUIRED: ● BUBBLE LEVEL ● HAMMER ● 2 x 4 BOARD

1. MAKE CERTAIN THE POWER SUPPLY IS TURNED OFF BEFORE STARTING INSTALLATION.
2. MOUNT BASE PLATE ON ANCHOR BOLTS. SEE FIG. 1 & ANCHOR BOLT MOUNTING TEMPLATE.  
ELECTRICAL CONDUIT SHOULD COME UP AS NEAR TO THE CENTER OF BOLT PATTERN AS POSSIBLE.
3. CONNECT SUPPLY LEADS OBSERVING POLARITY, LINE VOLTAGE TO BLACK, NEUTRAL TO WHITE & GREEN TO CIRCUIT GROUND.
4. CABLE TIE SUPPLY WIRES & EXTENDED LEADS SO CONNECTIONS ARE 6" MIN. ABOVE GROUND LEVEL.
5. SLIDE THE FIXTURE OVER THE BASE PLATE, ALIGN THE MACHINED HOLES IN THE BOTTOM OF THE EXTRUDED HOUSING WITH THE HOLES IN THE BASE PLATE. TO ENSURE ALIGNMENT, PARTIALLY INSTALL (4X) STAINLESS STEEL DRIVE PINS INTO HOUSING. AFTER ALIGNING, SET DRIVE PINS INTO HOLES BEING CAREFUL NOT TO DAMAGE FIXTURE PAINT FINISH. A 2 x 4 BOARD MAY BE USED TO PREVENT PAINT DAMAGE WHEN INSTALLING DRIVE PINS.

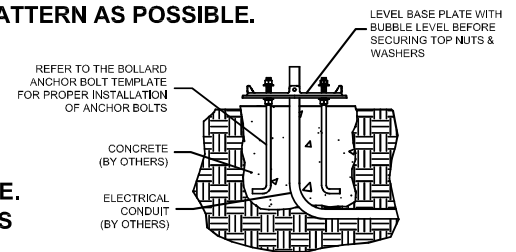

**FIG. 1**

**SERVICE:** TOOLS REQUIRED: ● 5/32 HEX KEY ● 7/16 WRENCH

1. MAKE CERTAIN THE POWER SUPPLY IS TURNED OFF BEFORE SERVICING.
2. LOOSEN 4EA 10-24 BTN HD CAP SCREWS WITH 5/32 HEX KEY. ROTATE CROWN ASSEMBLY COUNTER CLOCKWISE & LIFT OFF CROWN ASSEMBLY.
3. REMOVE 4EA 1/4-20 HEX CAP SCREWS, AND LIFT LED MODULE ASSY UP. SLIDE REFLECTOR UP, AND DISCONNECT LED MODULE CONNECTOR FROM DRIVER PLATE.
4. TO ACCESS DRIVER LOOSEN 4EA 1/4-20 HEX CAP SCREWS WHICH RETAIN OPTICAL HOUSING TO EXTRUDED HOUSING. REPLACE ALL PARTS & RE-TIGHTEN ALL FASTENERS AFTER SERVICING.

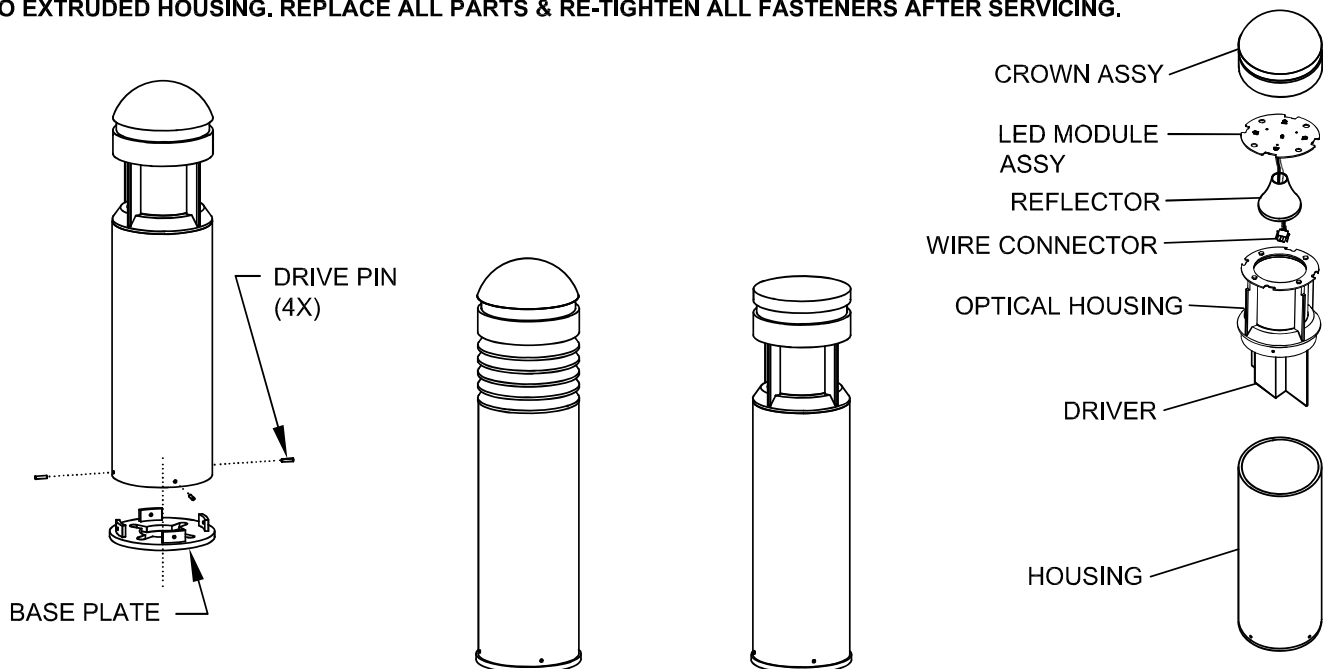

**XBVRD EL**

**XBVRF ID**

**INSTALLATION QUESTIONS?**  
 CALL LSI FIELD SERVICE  
 800-436-7800 EXT 3300  
 FAX 513-984-9723

