



Calculite features industry leading visual comfort, excellent uniform illumination over time, and patented installation flexibility. Optical cutoff of 50° coupled with exceptional 2 Step MacAdam ellipse color consistency make the Calculite 3" downlight an ideal choice for open office, retail, hospitality, healthcare, and residential applications.

Complete luminaire = Frame + Engine + Trim + Accessories (optional)
Complete remodel luminaire = Engine + Trim + Accessories (optional)

Project: _____
 Location: _____
 Cat.No: _____
 Type: _____
 Qty: _____
 Notes: _____

Frame

Note: For remodeler installations, order light engine and trim only (no frame needed).

example: 3SAS

Series	Installation	Voltage / Options	
3S			
3S Uniframe 3" square frame	N New Construction Non-IC	— Universal 120/277/347V ¹ LC Chicago plenum 3 347V (for non-0-10v configurations) ³	EM6 Emergency, 6W Self-Test/Self-Diagnostic ² RADIO Integral Interact Pro RF sensor (requires above ceiling access - enables wireless connected lighting control)
	A AirSeal IC (1000lm max)	— Standard Universal 120/277/347V ¹	S Shallow Universal 120/277/347V ^{1,4}

Engine

example: C3L10930NZ10US

Series	Lumens	CRI/CCT	Beam	Dimming / Voltage	Plenum
C3L					
C3L Calculite 3" light engine	05 500lm	927 90CRI/2700K	S Determined by trim	Z10U 0-10V 1% / Unv (120V/277V) Z103 0-10v 1% (347V) ^{6,7} LU Lutron PEQ0 (Dim to 0.1%) / Unv (120V/277V/347V) E1 Electronic low voltage (120V dimming)	— Standard
	07 750lm	930 90CRI/3000K			
	10 1000lm	935 90CRI/3500K			
	15 1500lm ⁵	940 90CRI/4000K			
	18 1800lm ⁵				
	10 1000lm	9D2W 90CRI/3000K-1800K for Non-IC (N) frames only			
	07 750lm	927 90CRI/2700K	S Determined by trim	Z10U 0-10V 1% / Unv (120V/277V) Z103 0-10v 1% (347V) ^{6,7} E1 ELV (120V dimming) / Unv (120V/277V/347V)	R Remodeler ⁸ (120/277V only) S Shallow
	10 1000lm	930 90CRI/3000K			
		935 90CRI/3500K 940 90CRI/4000K			

Trim

example: C3SDLWCCF

Accessories

Series	Style	Beam	Reflector	Flange	Flange
C3S	DL				
C3S Calculite 3" square trim	DL Downlight (for remodeler & new const.)	N Narrow (33°)	BK Black (painted)	— White (matte)	— Standard depth with 50° cutoff
		M Medium (59°)	CL Specular clear	F Flangeless ⁹	
		W Wide (71°)	CC Comfort clear		
			CD Comfort clear diffuse	WH White (matte)	— White (matte)
			WT Textured white (painted)	F Flangeless ⁹	S 1" regress cast aluminum (wide beam only)
			BT Textured black (painted)	P Matching reflector	
			BZ Bronze (painted)	F Flangeless ⁹	
			D Aluminum diffuse (painted)	— White (matte)	
				P Matching reflector	
				F Flangeless ⁹	

SBA
Interact Ready System Bridge Accessory (refer to Philips System Bridge Accessory specification sheet for options and ordering details)¹⁰

CAEM6
Field installable Bodine BSL6 6W battery pack with self-test/self-diagnostic for use with new construction frames, 120-277V

CA3SFT
Mud-in ring for use in flangeless installs (ordered with a flangeless trim) (order & install separately)

- Universal 120-347V is for 0-10v (Z10) dimming configurations only. For 347V non-Z10 dimming, order 347V (3) frame with (U) light engine/trim.
- Emergency (EM6) frame requires remote mounted test switch. Order CAEM6TSCP mounting plate accessory (not compatible with 347V).
- Not compatible with electronic low voltage light engine dimming option (E).
- Must order shallow IC frame (S), shallow engine (S) for complete shallow assembly. Standard depth and regress (S) trims are compatible with shallow light engines (S).
- The 1500lm (15) and 1800lm (18) options are not available with standard AirSeal IC frame (3SA-).
- Specify standard UNV frame for use with 347V light engines.
- The 347V light engine voltage option is available only with Z10 dimming option. For other dimming protocols order (U) light engine and 347V (3) frame.
- For remodeler installations, order light engine and trim only (no frame needed).
- Flangeless (F) trims require CA3SFT mud-in accessory for installation.
- Requires IRT9015 IR remote & Interact Pro App for commissioning.



C3SDL Calculite 3"

Square downlight

Frame-in-kits

New construction:

Galvanized stamped steel for dry or plaster ceilings. Preinstalled telescoping mounting bars from 13" to 24". For 4' distances, use 1/2" EMT, 1-1/2" x 1/2" U or C channel.

Max ceiling thickness is 1.25" (32mm)

Patented install mounting frame:

- Pre-installed mounting bars for fast and tool-less installs into T-grid & hat channel ceilings.
- Close-cut aperture design eliminates possibility of gap between ceiling opening and reflector flange.
- Separate wiring compartment for wiring frame to building allows inspection prior to light engine install.
- Simple plug-and-play connection between frame and light engine from below ceiling.

Dimming

All configurations are FCC Class A unless otherwise specified.

- Advance 0-10V 1% (Z10)
- Lutron PEQO Hi-lume Premier 0.1% EcoSystem
- Electronic low voltage (ELV) - Remodel and AirSeal IC Shallow are FCC Class B
- Dim to Warm (D2W) - option changes CCT from 3000K to 1800K gradually as it dims

Optical systems

Quality of light: 2 SDCM ensures color consistency from fixture to fixture and over the luminaire's long lifetime.

Construction: Precision formed high grade aluminum reflectors with options for anodized or painted finishes. Shallow die cast trims available in painted finish.

Comfort throughout the space:

True 50° physical cutoff.

Light engine

Quick connect power pack allow for easy installation and replacement from below ceiling with no need for additional wiring. This allows for:

- Frame and ceiling installation to be performed while still finalizing details such as lumen packages, CCT and control type.
- Easy replacement of electronics at end of life with minimal wasted material and labor required.
- Ease and upgradability of technology.
- Predicted 70% lumen maintenance to 57,000 hrs.
- Max operating ambient temperature of 30°C.
- 347V light engines are 0-10v dimming only and include dedicated 347V driver for use with universal 120/277/347V (U) frames. For 347V and non-0-10v dimming, order (U) light engine and 347V (3) frame (includes step down transformer).

Emergency

Bodine BSL6 6W battery pack with self-test/diagnostic functionality. Factory or field mounted to frame.

- For remote ceiling mounted test switch, order standard Trim (ex: C3SACC). Optional accessory ceiling mounting plate available (CAEM6TSCP) for remote mounted test switch.
- Refer to Calculite-LyteProfile-EasyLyte Emergency Battery Pack specification sheet for more details.

Options and accessories

Field Installed Emergency: Refer to Calculite-LyteProfile-EasyLyte Emergency Battery Pack specification sheet for more details.

CAEM6: Field install EM6 kit with Bodine BSL6 6W battery pack with self-test/self-diagnostic, mounts to new construction frames. Includes remote ceiling plate for test switch.

CAEM6TSCP: Ceiling cover plate for remote mounted EM6 test switch. 1/2" (25mm) hole, 4 3/8" (109mm) x 2 3/4" (69mm) rectangular. Includes two mounting screws.

Flangeless mud-in ring: Use **CA3SFT** for use with flangeless plaster installations.

Title 24 exceptions

- BK and CZ finishes
- Must be installed in shallow AirSeal IC Frame
- Must be ELV and 750lm or 1000lm only

ENERGY STAR® exceptions

- BZ and WH finishes
- 347V & Emergency voltage/options
- Lutron configurations
- Dim to Warm configurations

Labels and listings

- cULus listed for wet locations
- ENERGY STAR® certified
- CEC Title 24 JA8 certified
- CCEA (frames with *LC suffix)

Warranty



5 year limited warranty
Visit [Signify.com/warranties](https://www.signify.com/warranties) for more information on Signify's standard 5-year limited warranty on complete luminaire systems.

C3SDL Calculite 3"

Square downlight

This meticulously engineered downlight is pre-adjusted to 22.5° out of the box, saving installation time. It can be vertically adjusted to 45° with three quick turns of a screwdriver and locked into place.

0-10V electrical tables

Light engine	Input volts	Input current	Drive current	Input power
C3L05_Z10U/3	120 V	0.06 A	150 mA	7.0 W
	277 V	0.02 A		
C3L07_Z10U/3	120 V	0.08 A	220 mA	9.5 W
	277 V	0.03 A		
C3L10_Z10U/3	120 V	0.12 A	330 mA	13.6 W
	277 V	0.05 A		
C3L15_Z10U/3	120 V	0.16 A	450 mA	18.6 W
	277 V	0.07 A		
C3L18_Z10U/3	120 V	0.17 A	500 mA	20.4 W
	277 V	0.07 A		
C3L07_Z10US/3 C3L07_Z10UR	120 V	0.08 A	220 mA	9.4 W
	277 V	0.03 A		
C3L10_Z10US/3 C3L10_Z10UR	120 V	0.12 A	330 mA	14.1 W
	277 V	0.05 A		

ELV electrical tables

Light engine	Input volts	Input current	Drive current	Input power
C3L05_E1	120 V	0.05 A	150 mA	5.4 W
	277 V	0.02 A		
C3L07_E1	120 V	0.08 A	220 mA	8.7 W
	277 V	0.03 A		
C3L10_E1	120 V	0.11 A	330 mA	13.2 W
	277 V	0.05 A		
C3L15_E1	120 V	0.15 A	450 mA	17.4 W
	277 V	0.06 A		
C3L18_E1	120 V	0.17 A	500 mA	19.7 W
	277 V	0.07 A		
C3_A05_E1S C3_A05_E1R	120 V	0.08 A	220 mA	8.7 W
	277 V	0.03 A		
C3_A10_E1R C3_A10_E1S	120 V	0.11 A	330 mA	13.2 W
	277 V	0.05 A		

Lutron electrical tables

Light engine	Input volts	Input current	Drive current	Input power
C3L05_LU	120 V	0.06 A	150 mA	6.2 W
	277 V	0.02 A		
C3L07_LU	120 V	0.08 A	220 mA	8.8 W
	277 V	0.03 A		
C3L10_LU	120 V	0.12 A	330 mA	13.0 W
	277 V	0.05 A		
C3L15_LU	120 V	0.15 A	450 mA	17.7 W
	277 V	0.06 A		
C3L18_LU	120 V	0.17 A	500 mA	19.8 W
	277 V	0.07 A		

C3SDL Calculite 3"

Square downlight

interact

Interact Pro scalable system			
	Foundation	Advanced	Enterprise
Dimming, grouping, and zoning	✓	✓	✓
Bluetooth and ZigBee enabled	✓	✓	✓
Motion sensing and daylight harvesting	✓	✓	✓
Integration with 0-10V and phase dimming fixtures	✓	✓	✓
Code compliance	✓	✓	✓
Granular dimming and dwell time	✓	✓	✓
Energy reporting and monitoring		✓	✓
Scheduling		✓	✓
Demand response		✓	✓
BMS integration (BACnet)			✓
Floor plan visualization			✓
IoT sensors for wellness			✓
IoT Apps for productivity			✓

Currently supported maximum system size

To be able to design the lighting system correctly for the customer, it is important to know the prime characteristics of the system, its possibilities and limitations.

System level	
Total number of gateways	Unlimited
Total number of devices	200 per network
<ul style="list-style-type: none"> • luminaires with integrated sensors 	150
<ul style="list-style-type: none"> • smart TLEDS 	150
Total number of ZGP devices (sensors and switches)	50
<ul style="list-style-type: none"> • sensors 	30
<ul style="list-style-type: none"> • switches 	50
<ul style="list-style-type: none"> • zones and groups 	64
Group level	
Recommended number of lights	40 (recommended 25)
Number of ZGP devices	5
Number of scenes	16

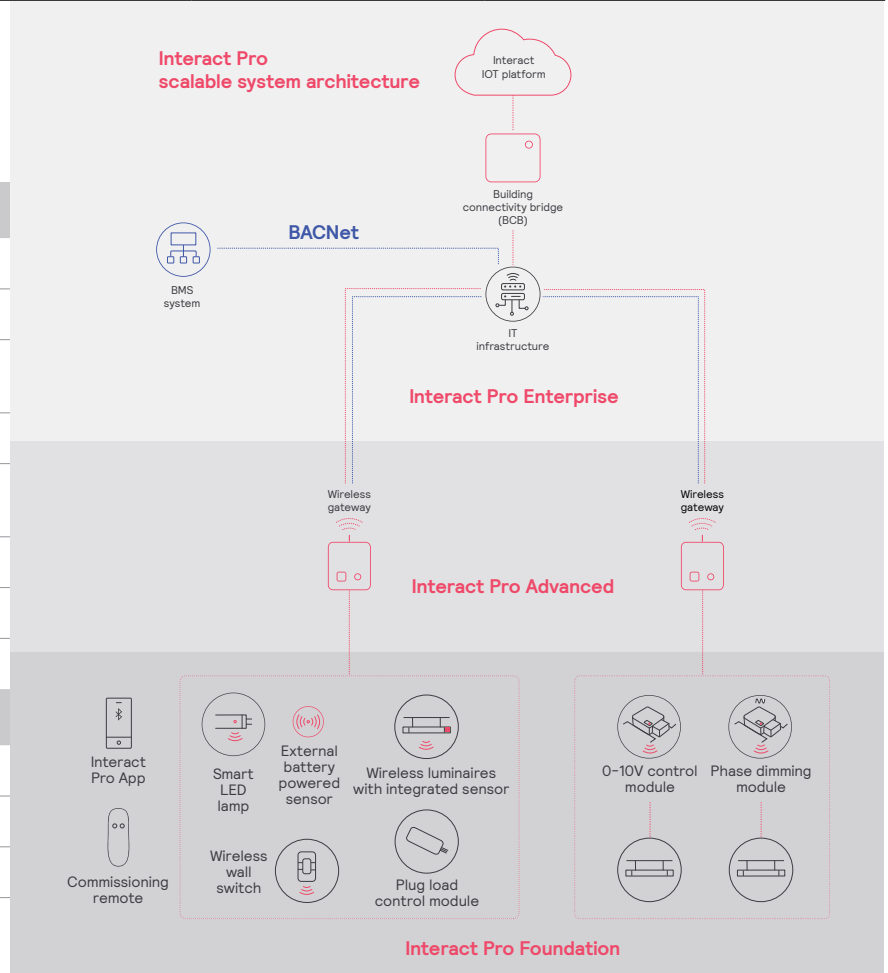

C3SDL Calculite 3"

Square downlight

Wireless Controls Options

Interact Pro scalable sensor (System Bridge Accessory with -CS option):

- CS is a connected sensor with integral occupancy and daylight sensing and supports wireless mesh connectivity.
- The sensor works in the Foundation mode (similar to SpaceWise) when configured without a gateway or in an Interact Pro Advanced or Enterprise mode if a compatible gateway is used.
- Interact Pro includes an App, a portal and a broad portfolio of wireless luminaires, lamps and retrofit kits all working on the same system.
- Startup is implemented via Interact Pro App (Android or iPhone) & Bluetooth connectivity. The App provides flexibility to choose between a gateway or non gateway mode for setup.
- Setup with the gateway requires wired internet access to the gateway. It is possible to add a gateway at a later point.
- Prepare project configuration steps remotely and use IRT9015 remote onsite to identify and group devices together.
- Compatible with:
 - UID8451/10 wireless dimmer switch
 - SWS200 wireless scene switch
 - Battery powered IP42 presence sensor OCC sensor IA CM WH 10/1
 - Battery powered IP42 presence & daylight sensor OCC-DL sensor IA CM IP42 WH
 - Battery powered IP65 presence sensor OCC sensor IA CM IP65 WH
 - Battery powered IP65 presence & daylight sensor OCC-DL sensor IA CM IP65 WH
- For more information on Interact Pro visit: www.interact-lighting.com/interactproscalablesystem.

Interact Pro Enterprise (System Bridge Accessory with -SB option):

- A wireless IoT connected lighting solution for large enterprises that span across multiple floors, buildings and require multiple gateways.
- View all your projects under one dashboard and easily compare insights from multiple projects in one view.
- Compatible with UID8451/10 wireless dimmer switch, SWS200 wireless scene switch, wireless Occ sensor (OCC SENSOR IA CM IP42 WH 10/1) and wireless Day/Occ sensor (OCC MULTI SENSOR IA CM WH 10/1) and wireless Occupancy or Daylight & Occupancy sensors available.
- Use Interact software and insights to increase building efficiency, achieve building wide integration and optimize space through occupancy analytics.
- SB option in addition to occupancy and daylight sensing supports advanced IoT capabilities such as people estimation analysis, desk level temperature & humidity sensing, noise classification, and BLE beacon.
- Requires compatible Gateway and internet connectivity for commissioning.
- For more information, visit: www.interact-lighting.com/office or www.usa.lighting.philips.com/systems/system-areas/offices.

Emergency Options (ER100) (System Bridge Accessory with -ER100 option):

- Power Sensing (Factory default) – Recommended UL924 option requires unswitched power sense line, absence of voltage on the normal circuit triggers luminaire to 100% output
- Power Interruption Detection (Field option) – Detects AC power interruption >30ms triggers 90 minute emergency mode with luminaire at 100% output

Radio only sensor (RADIO):

- Integral RADIO only sensor simply enables wireless mesh connectivity to the luminaire without any occupancy or daylight sensing.
- Ideal for applications where sensing functionality is managed by other Interact devices and the luminaire only needs to have wireless connectivity.

Wired Controls Options

Interact Office Wired (PoE):

- PoE based IoT connected lighting solution for large enterprises that span across multiple floors, buildings and require multiple gateways.
- Use Interact Office software and insights to increase building efficiency, achieve building wide integration and optimize space through occupancy analytics.
- Supports advanced IoT Apps on Personal Control, Space Management, wayfinding, room/desk reservation and offers open APIs for light control and data exchange.
- PoE lighting controller is accessible from below.
- Integral sensor option for occupancy sensing (PIR) and/or daylight harvesting available for additional energy savings.

- Optional integral emergency controller and battery pack provides 600lm nominal output.
- Test switch and indicator light mounted on side of chassis on one end.
- Emergency battery has a 3 month pre-installed shelf life, and must be stored and installed in environments of 20C to 30C (-4F to 86F) ambient, and 45-85% relative humidity.
- For more information on Interact Office Wired, visit: www.interact-lighting.com/office or www.usa.lighting.philips.com/systems/system-areas/offices.

Interact Office Wired (PoE), Static White:

- A wireless IoT connected lighting solution for large enterprises that span across multiple floors, buildings and require multiple gateways.

- View all your projects under one dashboard and easily compare insights from multiple projects in one view.
- Compatible Zigbee Green Power wall dimmer and wireless Occupancy or Daylight & Occupancy sensors available.
- Use Interact Office software and insights to increase building efficiency, achieve building wide integration and optimize space through occupancy analytics.
- Supports advanced IoT Apps on wayfinding, room/desk reservation and offers open APIs
- Requires compatible Interact Office Gateway and internet connectivity for commissioning.
- For more information on Interact Office Wireless, visit: www.interact-lighting.com/office or www.usa.lighting.philips.com/systems/system-areas/offices.

C3SDL Calculite 3"

Square downlight

New construction (N)

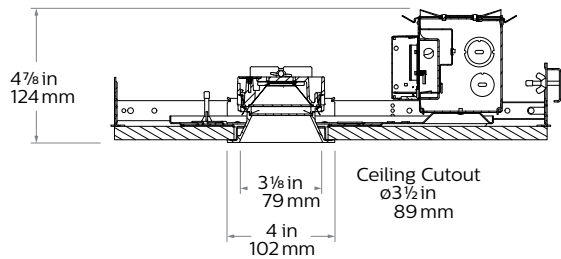
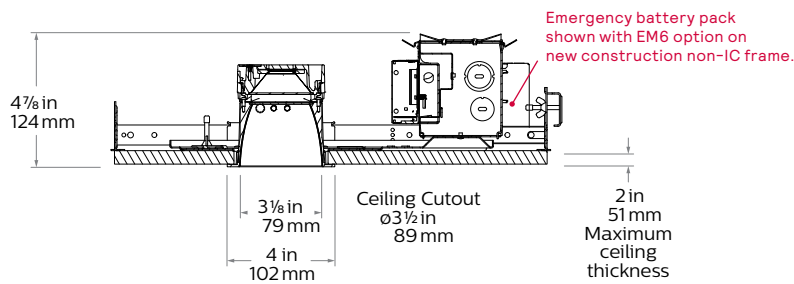
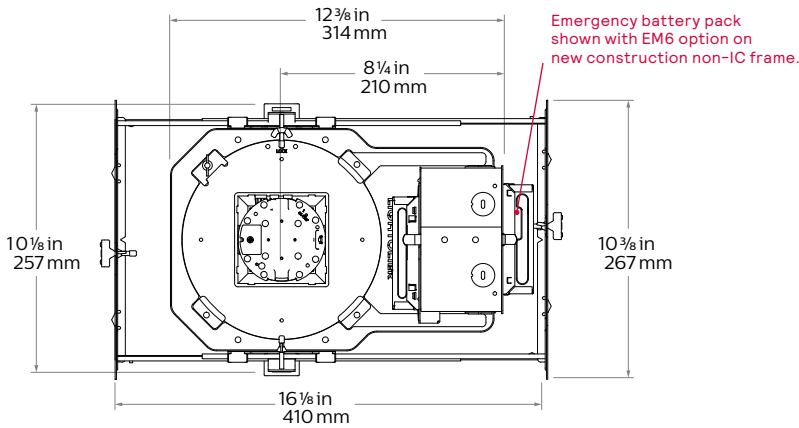

Remodeler (R)

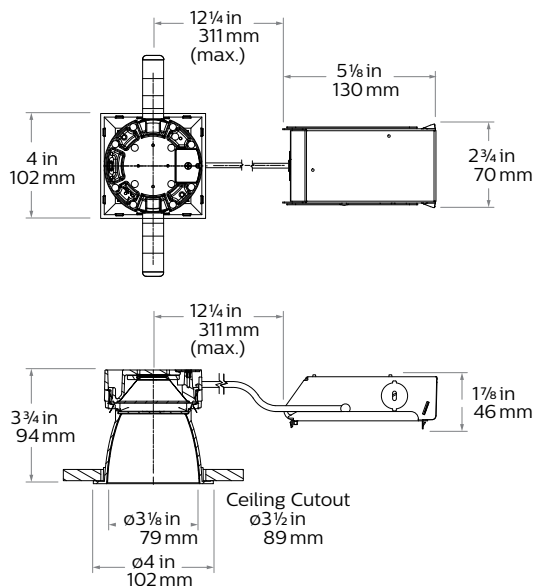

Standard IC (A) and Chicago plenum (LC)

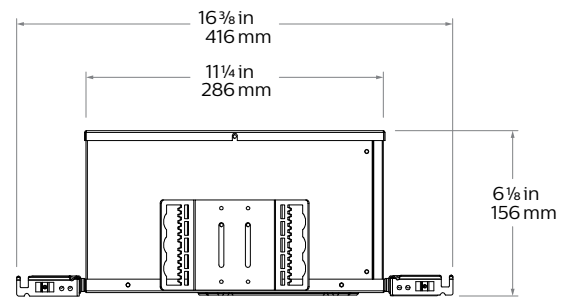
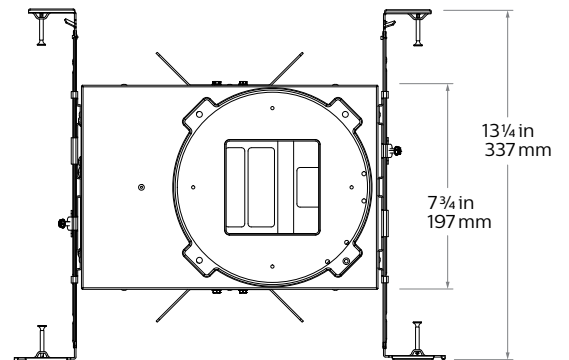

Shallow IC (S)

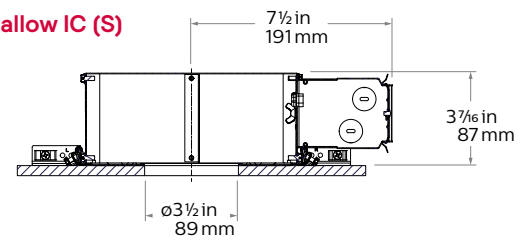

Flangeless mud-in ring (CA3SFT) accessory

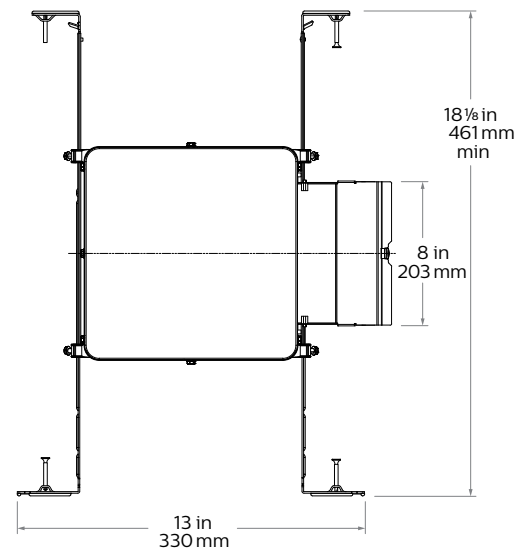
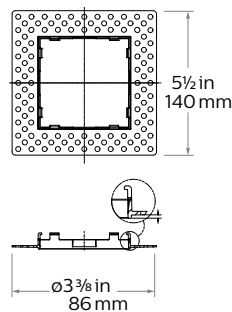

C3SDL Calculite 3"

Square downlight

Polished Reflectors Shown as round reflectors but represent the finish of Calculite square reflectors.



Specular clear (CL): Most specular and most efficient finish, delivers maximum photometric performance but can produce a mirror image effect of the interior space.



Comfort clear (CC): Semi-specular finish that softens the light at the source of the reflector and creates a subtle, even luminance from the reflector cone.



Comfort clear diffuse (CD): Slightly diffuse clear finish, that eliminates iridescence and reduces the mirror image effect inherent with specular finishes.



White (WH): (matte) Brightest illuminated aperture and provides the smoothest transition to most ceilings when off (white is only available with a white flange).



Black (BK): (anodized) Specular finish that provides the lowest aperture brightness possible and significantly reduces source identification in a ceiling.

Textured Reflectors Shown as square reflectors but represent the finish of Calculite round reflectors.



Aluminum diffuse (D):
Matte painted finish.



Textured white (WT):
Matte painted finish.



Bronze (BZ):
Matte painted finish.



Textured black (BT):
Matte painted finish.

Flanges



White (-): (matte) Provides the smoothest transition to ceilings when off.



Polished (P): (matches aperture) Produces a continuous look throughout the reflector (aperture matching).



Flangeless (F): (flush-mount) Creates a flush, virtually seamless transition from aperture to ceiling.

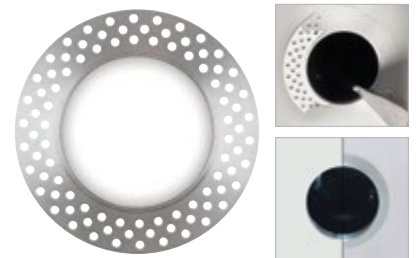

Mud-in ring (FT): Low profile, machined aluminum mud-in ring provides a raised rib to plaster up to and a 3/16" flange thickness. The ring is attached to the ceiling material as opposed to the frame-in kit to avoid conduction of heat and vibration which can cause yellowing or cracking of the plaster.

C3SDL Calculite 3"

Square downlight

Narrow beam (standard), 1000lm engine, 76.9 lm/W at 14W

Candela Curve

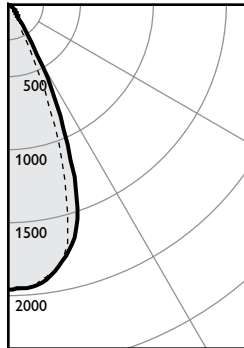

Frame: 3SN
Engine: C3L10935SZ10U
Trim: C3SDLNCC

Output lumens: 1077 lms
Input watts: 14 W
CRI: 90 min
CCT: 3500K
Spacing Crit.: 0.69

Zonal summary

Zone	Lumens	%Luminaire
0-30	914	84.9%
0-40	1010	93.8%
0-60	1070	99.4%
0-90	1077	100.0%

H/V	0	45	90
0	1950	1953	1949
5	1949	1940	1920
15	1635	1717	1574
25	468	839	397
35	148	147	141
45	63	58	53
55	13	9	13
65	5	4	5
75	2	2	2
85	0	1	1
90	0	0	1

Single unit data

Height to lighted plane	Initial center beam foot-candles	Beam diameter (ft)*
5'	78	3.5'
6'	54	4.1'
7'	40	4.8'
8'	30	5.5'
9'	24	6.2'

* Beam diameter is where foot-candles drop to 50% of maximum.

Multiple unit data - RCR 2

Spacing on center	Initial center beam foot-candles	Watts per sq. ft.
5'	50.0	0.62
6'	33.0	0.41
7'	23.0	0.29
8'	20.0	0.24
9'	16.0	0.19

38' x 38' x 10' Room, Workplane 2.5' above floor, 80/50/20% Reflectances

Efficacy: 76.9lm/w
Report#: 1784GFR

Adjustment Factors

Standard	CCT	Lumens
CL = 110%	90CRI 4000K = 104%	1800lm = 142%
CC = 100%	90CRI 3500K = 100%	1500lm = 130%
CD = 88%	90CRI 3000K = 96%	1000lm = 100%
WH = 88%	90CRI 2700K = 90%	750lm = 70%
BK = 65%		500lm = 50%

Coefficients of utilization

Ceiling	80%				70%		50%		30%		0%
	70	50	30	10	50	10	50	10	50	10	0
Wall	70	50	30	10	50	10	50	10	50	10	0
RCR	Zonal cavity method - Effective floor reflectance = 20%										
Room Cavity Ratio	0	119	119	119	116	116	111	111	106	106	100
1	114	112	109	107	109	106	105	102	102	99	95
2	109	105	101	98	103	97	100	95	97	93	89
3	105	99	94	91	98	90	95	89	93	87	85
4	100	93	89	85	92	84	90	83	88	82	80
5	96	89	84	80	88	79	86	79	84	78	76
6	92	84	79	75	84	75	82	75	81	74	72
7	88	80	75	71	80	71	78	71	77	70	69
8	85	77	71	68	76	68	75	67	74	67	66
9	82	73	68	65	73	65	72	64	71	64	63
10	79	70	65	62	70	62	69	61	68	61	60

Medium beam (standard), 1000lm engine, 73.8 lm/W at 14W

Candela Curve

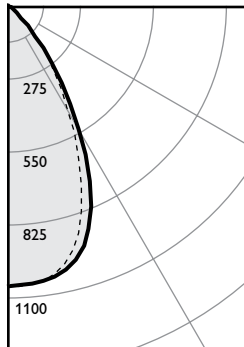

Frame: 3SN
Engine: C3L10935SZ10U
Trim: C3SDLMCC

Output lumens: 996 lms
Input watts: 13.5 W
CRI: 90 min
CCT: 3500K
Spacing Crit.: 0.88

Zonal summary

Zone	Lumens	%Luminaire
0-30	681	68.4%
0-40	888	89.2%
0-60	988	99.2%
0-90	996	100.0%

H/V	0	45	90
0	1941	1945	1941
5	1941	1933	1914
15	1620	1711	1573
25	461	835	403
35	148	146	141
45	62	58	54
55	13	9	13
65	5	4	5
75	2	2	2
85	0	1	1
90	0	0	1

Single unit data

Height to lighted plane	Initial center beam foot-candles	Beam diameter (ft)*
5'	42	4.4'
6'	29	5.3'
7'	22	6.2'
8'	17	7.0'
9'	13	7.9'

* Beam diameter is where foot-candles drop to 50% of maximum.

Multiple unit data - RCR 2

Spacing on center	Initial center beam foot-candles	Watts per sq. ft.
5'	45.0	0.60
6'	30.0	0.39
7'	21.0	0.28
8'	18.0	0.23
9'	14.0	0.19

38' x 38' x 10' Room, Workplane 2.5' above floor, 80/50/20% Reflectances

Efficacy: 73.8lm/w
Report#: F41038GFR

Adjustment Factors

Standard	CCT	Lumens
CL = 110%	90CRI 4000K = 104%	1800lm = 142%
CC = 100%	90CRI 3500K = 100%	1500lm = 130%
CD = 88%	90CRI 3000K = 96%	1000lm = 100%
WH = 88%	90CRI 2700K = 90%	750lm = 70%
BK = 65%		500lm = 50%

Coefficients of utilization

Ceiling	80%				70%		50%		30%		0%
	70	50	30	10	50	10	50	10	50	10	0
Wall	70	50	30	10	50	10	50	10	50	10	0
RCR	Zonal cavity method - Effective floor reflectance = 20%										
Room Cavity Ratio	0	119	119	119	116	116	111	111	106	106	100
1	113	111	108	106	108	105	105	101	101	98	94
2	108	103	98	95	101	95	99	92	96	91	88
3	102	95	90	86	94	87	93	84	90	85	82
4	97	89	83	79	88	81	87	78	85	79	76
5	92	83	77	73	82	75	82	72	81	74	71
6	87	78	72	67	77	70	78	67	76	69	67
7	82	73	67	63	72	65	73	62	72	65	63
8	78	69	63	58	68	61	70	58	69	61	59
9	75	65	59	55	64	58	66	54	65	57	56
10	71	61	55	51	61	54	63	51	62	54	53

1. Correlated Color Temperature within specs as defined in ANSI_NEMA_ANSI C78.377-2008: Specifications for the Chromaticity of Solid State Lighting Products.
2. Tested using absolute photometry as specified in LM79: IESNA Approved Method for the Electrical and Photometric Measurements of Solid-State Lighting Products.

C3SDL Calculite 3"

Square downlight

Wide beam (standard), 1000lm engine, 68.3 lm/W at 14W

Candela Curve

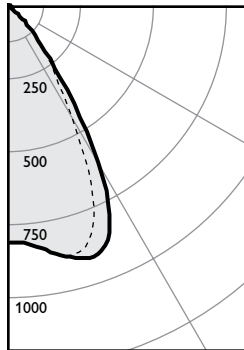

Frame: 3RN
Engine: C3L10935SZ10U
Trim: C3SDLWCC

Output lumens: 956 lms
Input watts: 14 W
CRI: 90 min
CCT¹: 3500K
Spacing Crit.: 1.02

Zonal summary

Zone	Lumens	%Luminaire
0-30	660	69.0%
0-40	856	89.5%
0-60	948	99.2%
0-90	956	100.0%

H/V	0	45	90
0	811	811	810
5	819	818	819
15	873	887	871
25	679	815	641
35	267	351	258
45	94	94	83
55	17	14	16
65	6	4	6
75	2	2	2
85	0	1	1
90	0	0	1

Single unit data

Height to lighted plane	Initial center beam foot-candles	Beam diameter (ft)*
5'	32	5.1'
6'	23	6.1'
7'	17	7.1'
8'	13	8.2'
9'	10	9.2'

* Beam diameter is where foot-candles drop to 50% of maximum.

Multiple unit data - RCR 2

Spacing on center	Initial center beam foot-candles	Watts per sq. ft.
5'	43.0	0.62
6'	28.0	0.41
7'	20.0	0.29
8'	17.0	0.24
9'	14.0	0.19

38' x 38' x 10' Room, Workplane 2.5' above floor, 80/50/20% Reflectances

Efficacy: 68.3lm/w
Report#: 1781GFR

Adjustment Factors

Standard	CCT	Lumens
CL = 110%	90CRI 4000K = 104%	1800lm = 142%
CC = 100%	90CRI 3500K = 100%	1500lm = 130%
CD = 88%	90CRI 3000K = 96%	1000lm = 100%
WH = 88%	90CRI 2700K = 90%	750lm = 70%
BK = 65%		500lm = 50%

Coefficients of utilization

Ceiling	80%				70%				50%				30%				0%
	70	50	30	10	50	10	50	10	50	10	50	10	50	10			
RCR	Zonal cavity method - Effective floor reflectance = 20%																
Room Cavity Ratio	0	119	119	119	116	116	111	111	106	106	100	100	100	100	100		
1	113	110	108	106	108	104	104	101	101	98	98	93	93	93	93		
2	107	102	98	95	101	94	98	92	95	90	86	86	86	86	86		
3	102	95	90	86	94	86	91	84	89	83	80	80	80	80	80		
4	96	89	83	78	87	78	86	77	84	77	74	74	74	74	74		
5	91	83	77	72	82	72	80	71	79	71	69	69	69	69	69		
6	86	77	71	67	76	67	75	66	74	66	64	64	64	64	64		
7	82	72	66	62	72	62	71	61	70	62	60	60	60	60	60		
8	78	68	62	57	67	58	67	57	66	58	56	56	56	56	56		
9	74	64	58	54	63	55	63	53	62	54	53	53	53	53	53		
10	70	60	54	50	60	51	60	50	59	51	49	49	49	49	49		

Wide beam (shallow), 1000lm engine, 73.1 lm/W at 14.1W

Candela Curve

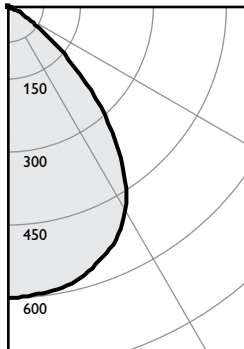

Frame: 3RN
Engine: C3L10935SZ10U
Trim: C3SDLWDS

Output lumens: 1031 lms
Input watts: 13.6 W
CRI: 14.1 min
CCT¹: 3500K
Spacing Crit.: 1.2

Zonal summary

Zone	Lumens	%Luminaire
0-30	515	48.0%
0-40	783	72.9%
0-60	1037	96.6%
0-90	1074	100.0%

Angle	Mean CP	Lumens
0	597	
5	592	60
10	588	
15	570	162
20	553	
25	518	240
30	481	
35	409	253
40	334	
45	237	174
50	151	70
55	85	
60	52	28
65	28	
70	11	6
75	5	
80	3	1
85	1	
90	0	

Single unit data

Height to lighted plane	Initial center beam foot-candles	Beam diameter (ft)*
5'	24	6.0'
6'	17	7.2'
7'	12	8.4'
8'	9	9.6'
9'	7	10.8'

* Beam diameter is where foot-candles drop to 50% of maximum.

Multiple unit data - RCR 2

Spacing on center	Initial center beam foot-candles	Watts per sq. ft.
5'	45.0	0.62
6'	30.0	0.41
7'	21.0	0.29
8'	18.0	0.24
9'	14.0	0.20

38' x 38' x 10' Room, Workplane 2.5' above floor, 80/50/20% Reflectances

Efficacy: 73.1lm/w
Report#: 1785GFR

Adjustment Factors

Shallow	CCT	Lumens
WT = 112%	90CRI 4000K = 104%	1800lm = 142%
WH = 110%	90CRI 3500K = 100%	1500lm = 130%
D = 100%	90CRI 3000K = 96%	1000lm = 100%
BZ = 77%	90CRI 2700K = 90%	750lm = 70%
BK = 75%		500lm = 50%
BT = 74%		

Coefficients of utilization

Ceiling	80%				70%				50%				30%				0%
	70	50	30	10	50	10	50	10	50	10	50	10	50	10			
RCR	Zonal cavity method - Effective floor reflectance = 20%																
Room Cavity Ratio	0	119	119	119	116	116	111	111	106	106	100	100	100	100	100		
1	112	109	105	103	106	101	102	98	98	95	90	90	90	90	90		
2	105	98	93	89	97	88	93	86	90	84	80	80	80	80	80		
3	97	89	83	78	88	78	85	76	83	75	72	72	72	72	72		
4	91	81	75	69	80	69	78	68	76	67	64	64	64	64	64		
5	85	74	67	62	73	61	71	61	70	60	58	58	58	58	58		
6	79	68	61	55	67	55	66	55	64	54	52	52	52	52	52		
7	74	63	55	50	62	50	61	50	59	49	47	47	47	47	47		
8	70	58	51	46	57	46	56	45	55	45	43	43	43	43	43		
9	65	54	47	42	53	42	52	41	51	41	39	39	39	39	39		
10	62	50	43	38	49	38	48	38	48	38	36	36	36	36	36		

1. Correlated Color Temperature within specs as defined in ANSI_NEMA_ANSI C78.377-2008: Specifications for the Chromaticity of Solid State Lighting Products.
2. Tested using absolute photometry as specified in LM79: IESNA Approved Method for the Electrical and Photometric Measurements of Solid-State Lighting Products.

