

ULTRA 35 Pole Spot

INSTALLATION INSTRUCTIONS UK/AU/NZ

Important! Please read before installing the Fixture

Warning: Do not connect secondary side (output) of a live driver to the Fixture. This will cause a spike in voltage that can damage the LED. When connecting or disconnecting the fitting always insure the 120/240V power supply is disconnected.

Warning: When using a photocell and/or timer we recommend using devices with relay outputs as opposed to electronic. The high frequency of electronic devices can lead to failure of the LED driver.

Follow the diagram opposite to correctly install the Fixture.

Remove the Pole Spot head from the pole by un-doing the three fixing screws at the top of pole. This will allow you to pull the head with bracket and top cap free.

Note: top of the pole is indicated by the 3 grub screw holes

Cast the pole into the ground. We recommend casting the pole into the ground with concrete to a minimum depth of 300mm (12"). Be sure to place free draining material in the base of the hole. This will allow water to drain away and stop the water level building up in the pole.

Once ground works are complete and the pole is correctly set into place, draw the power supply and dimming cables up through the pole. Allow for 200mm (8") extra above top of the pole.

Make sure waterproof connections to the luminaire input cable and dimming cable. A non waterproof connection will allow water to ingress into power supply and/or fixture head which can lead to failure.

See diagrams below for correct wiring.

Finish installation by securing the Luminaire Head/Cap to the top of pole with the three fixing screws.

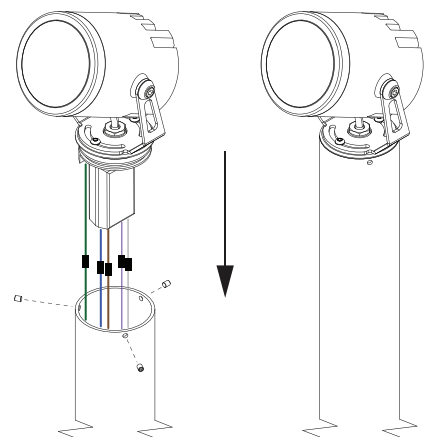
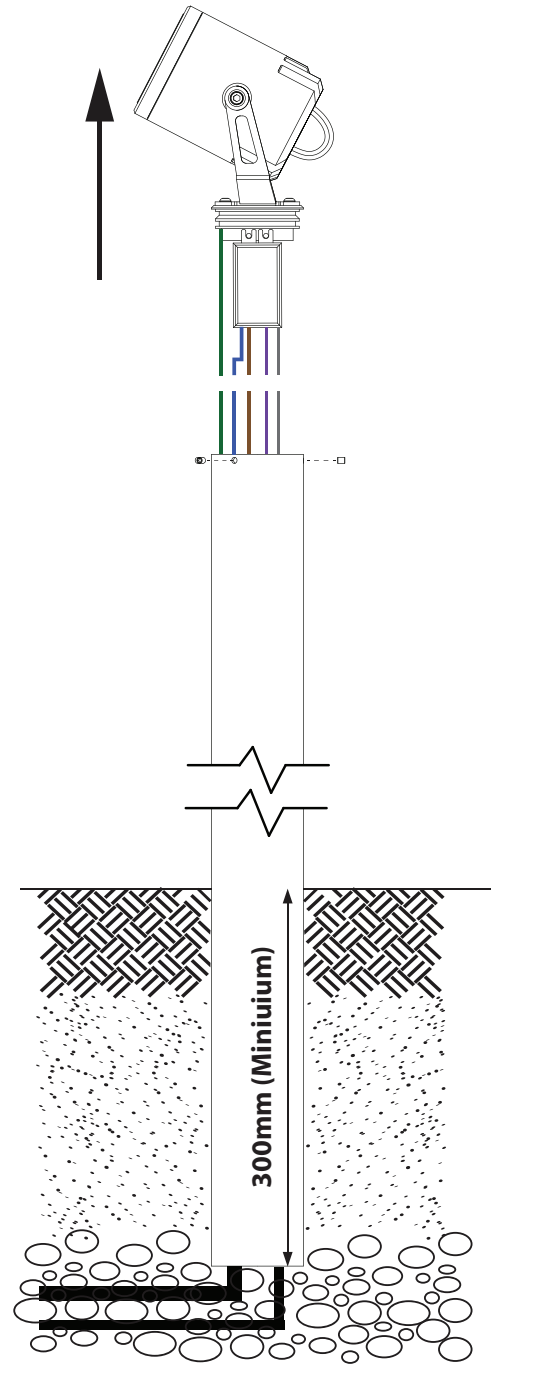

120/240V (RETRO) CONNECTIONS

Make input connections according to diagram below.

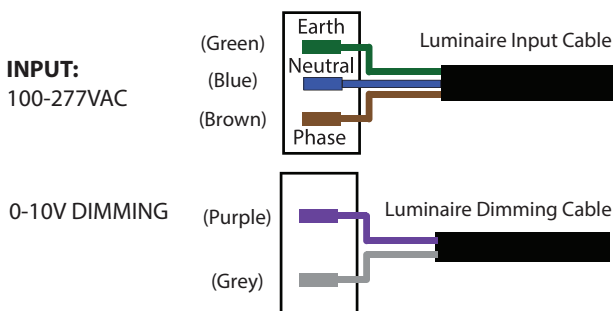

REMOTE DRIVEN (SERIES) CONNECTIONS

Make input connections according to diagram below.

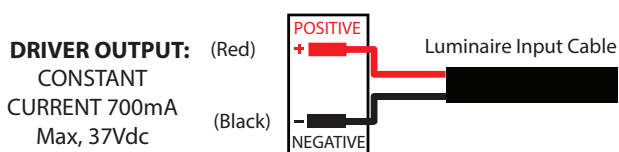

Oct 2021 V1

UK/AU/NZ

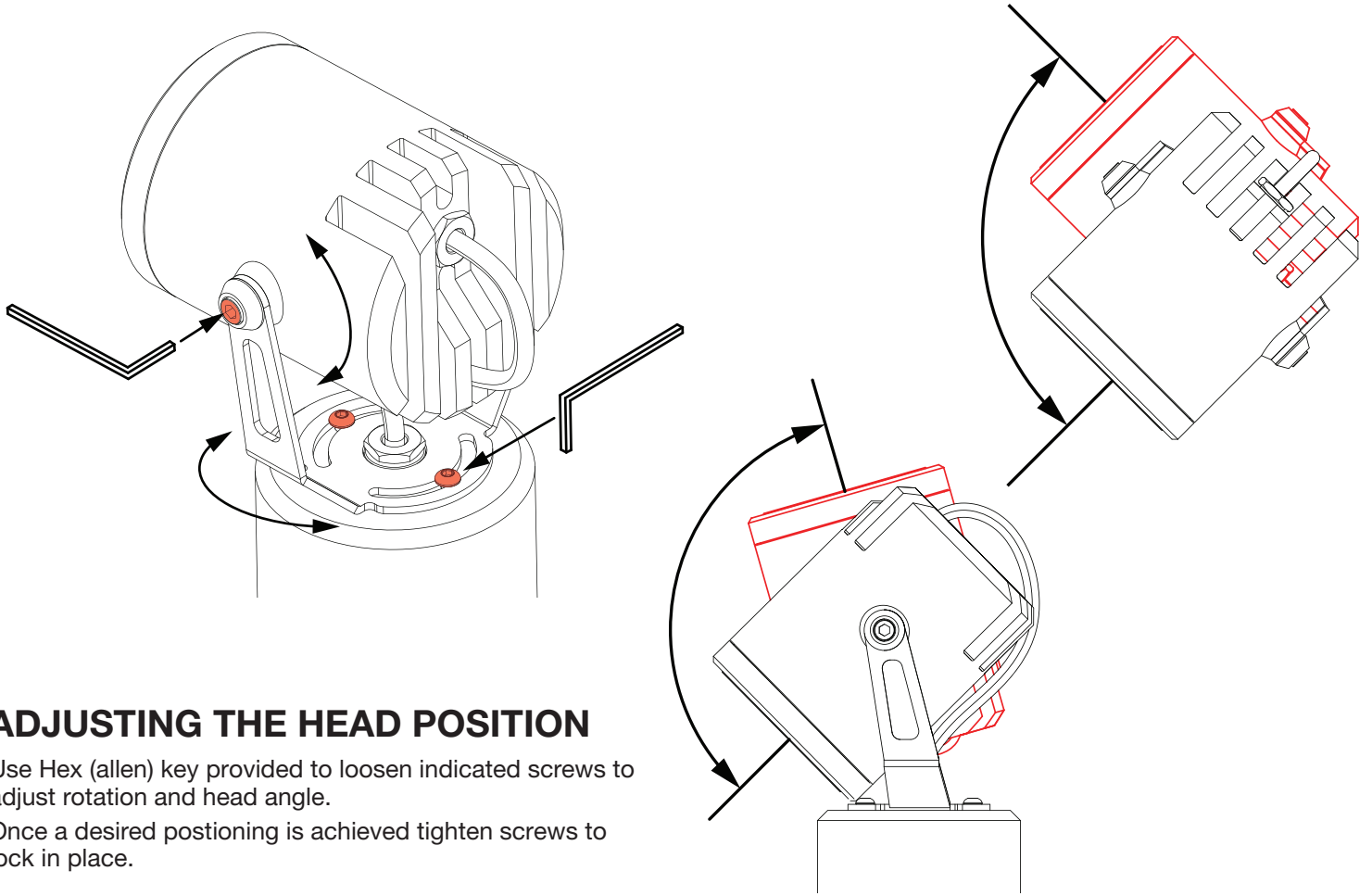

ADJUSTING THE HEAD POSITION

Use Hex (allen) key provided to loosen indicated screws to adjust rotation and head angle.

Once a desired positioning is achieved tighten screws to lock in place.

LED REPLACEMENT

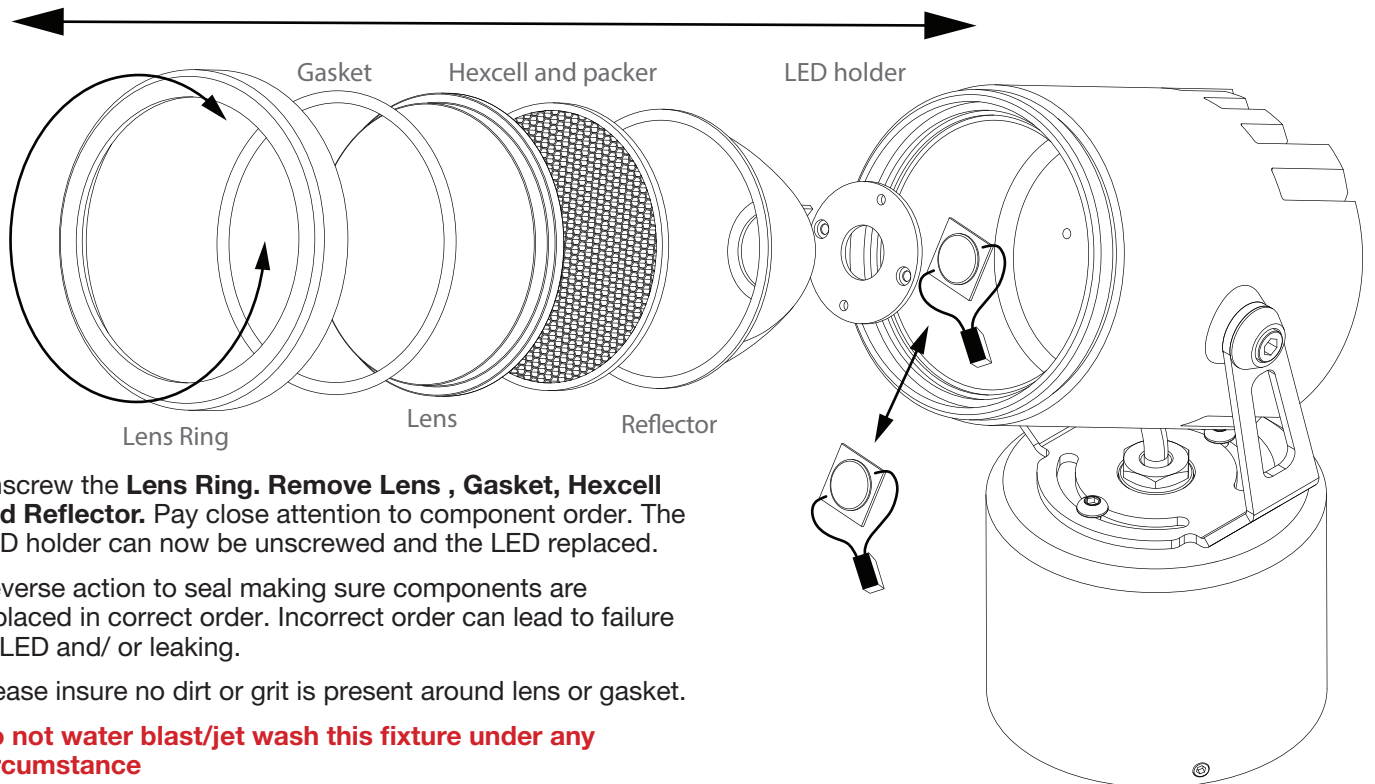

Unscrew the **Lens Ring, Remove Lens, Gasket, Hexcell and Reflector**. Pay close attention to component order. The LED holder can now be unscrewed and the LED replaced.

Reverse action to seal making sure components are replaced in correct order. Incorrect order can lead to failure of LED and/ or leaking.

Please insure no dirt or grit is present around lens or gasket.

Do not water blast/jet wash this fixture under any circumstance