

Pillar Lite High Power RGBW PURE LED

SPECIFICATIONS

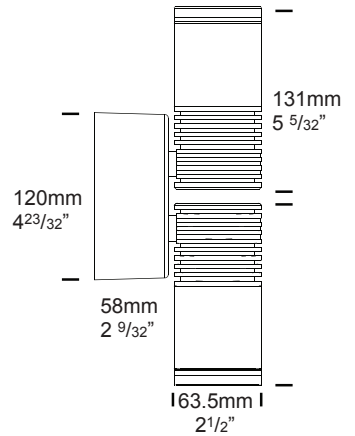

LED Chip	LED Engin Plug and Play field replaceable LED board
Luminaire Output	2x 1000 total Lumens @250mA (20 Watts per light engine) with all colours on, delivered from luminaire with unobstructed beam
Lumens Per Watt	54 Lumens minimum @ 20 watts, delivered from luminaire with unobstructed beam
CRI (6500K)	75CRI White - 6500K
Colour Temperatures	6500K White + Red, Blue, Green
Beam Angles	15, 30, 40, 70
Ingress Protection	IP66
Warranty	Electronics = 5 years Body Aluminium = 5 years
Standards	AS/NZS 61046, EN60598 cUL 1838, 2108, 1598 CSA C22.2 No. 250.7, No. 250.0-08, No. 250.0 CE

PRODUCT CONFIGURATION

Please fill in appropriate codes into boxes provided

Cat. No. DL/HPRGBW

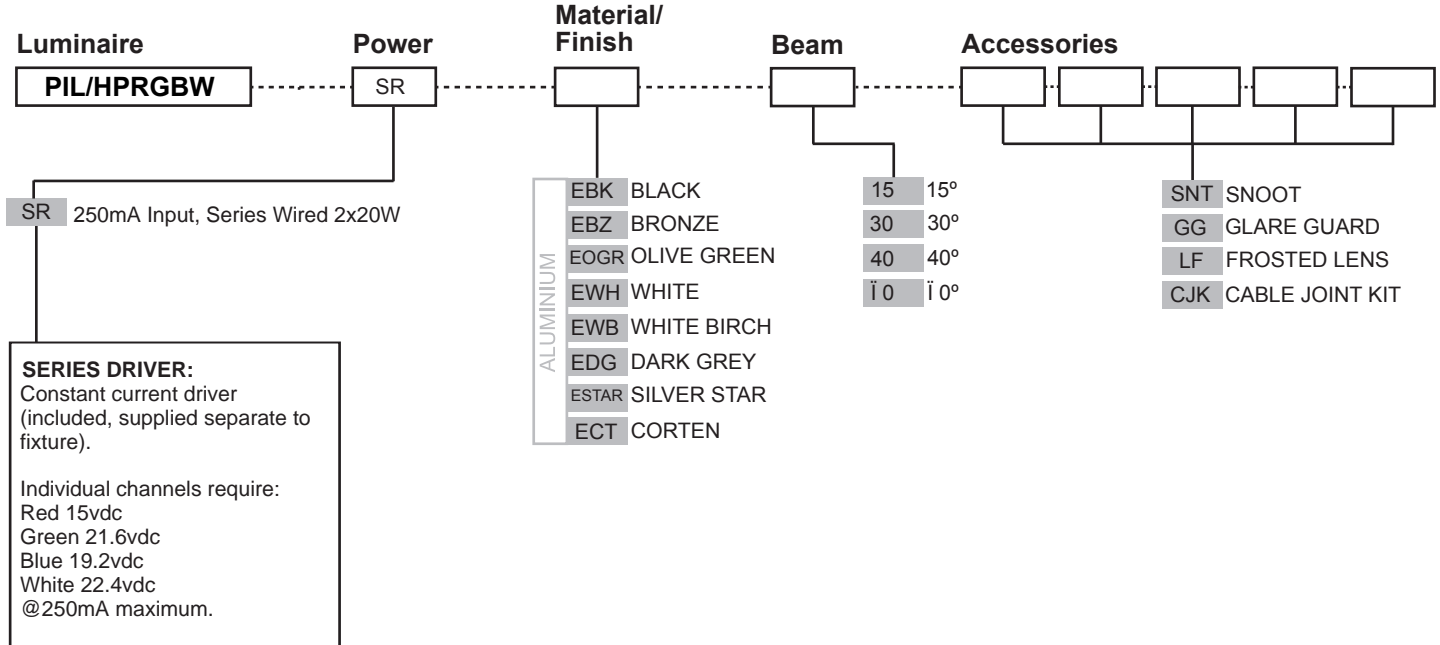

ADDITIONAL COMMENTS:

LUMINAIRE CONSTRUCTION

CNC machined from one of the following metals:

Aluminium:

Body: high corrosion resistant 63.5mm solid aluminium tube with chromate substrate and high UV resistant polyester "E" powder coat.

Colours:

Black, Bronze, Silver Star, White, White Birch, Olive Green, Dark Grey, Corten.

Mounting:

A mounting plate is fixed to the wall using two screws and the luminaire is fitted to the mounting plate.

Luminaire Weight:

Low voltage:
Alum: 0.870 (1lb 15oz)

Lens:

10mm (3/8") Extra clear, low iron, shatter resistant glass.
Lifetime warranty.

Gaskets:

Silicone, iron impregnated 220°C (428°F)

ACCESSORIES

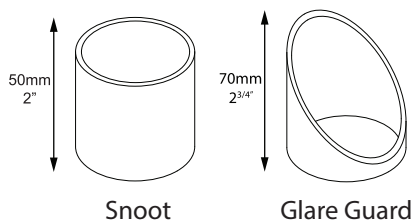

BEAM ANGLES

High efficiency PMMA TIR lenses. Field replaceable

IES files available for download: hunzalighting.com/downloads

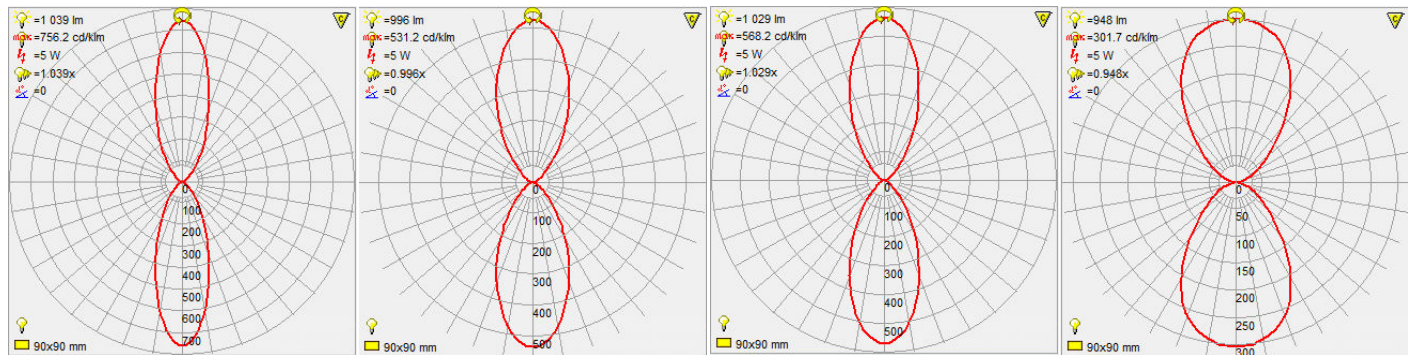

WIRING GUIDE

Available for download: hunzalighting.com/downloads

CONSTANT CURRENT - SERIES WIRED

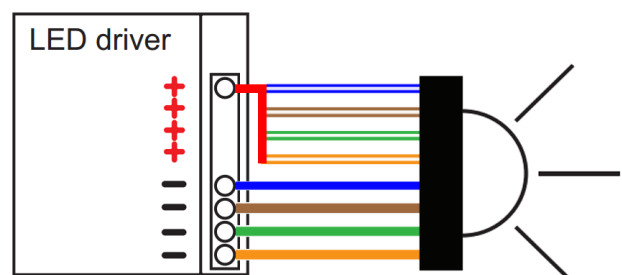
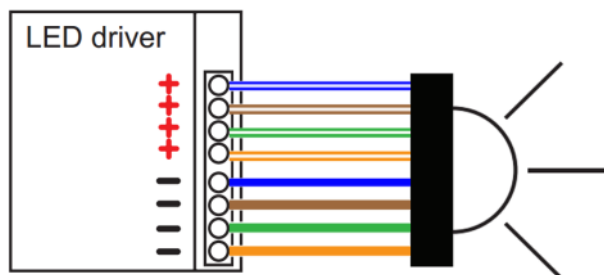

Specifications may change without notification

Sept 2020