

BLADE Installation instructions

Follow Diagram opposite to correctly fix the Base Plate to the desired surface. Fixing screws are provided however some mediums may require different fixing hardware. If so please ensure the fixing hardware is adequate to take the weight of the fixture.

After Base Plate has been fixed in place make the input connections. All connections should be water tight to stop water ingress into the fixture via power cables.

See diagrams below

Warning: Do not connect secondary side (output) of a live driver to the Fixture. This will cause a spike in voltage that can damage the LED. When connecting or disconnecting the fitting always ensure the 120/240V power supply is disconnected.

When using a photocell and/or timer we recommend using devices with relay outputs as opposed to electronic. The high frequency of electronic devices can lead to failure of the LED driver.

100mm (4") junction box compatible

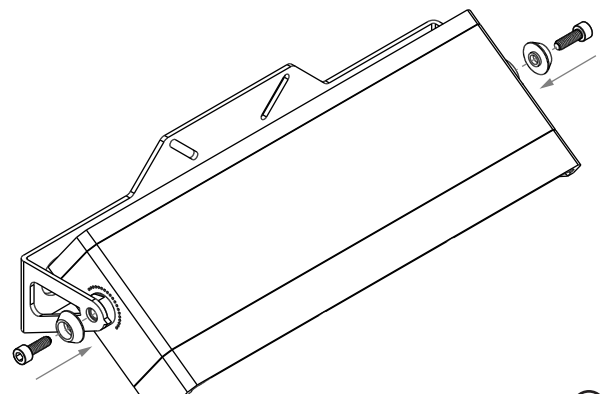
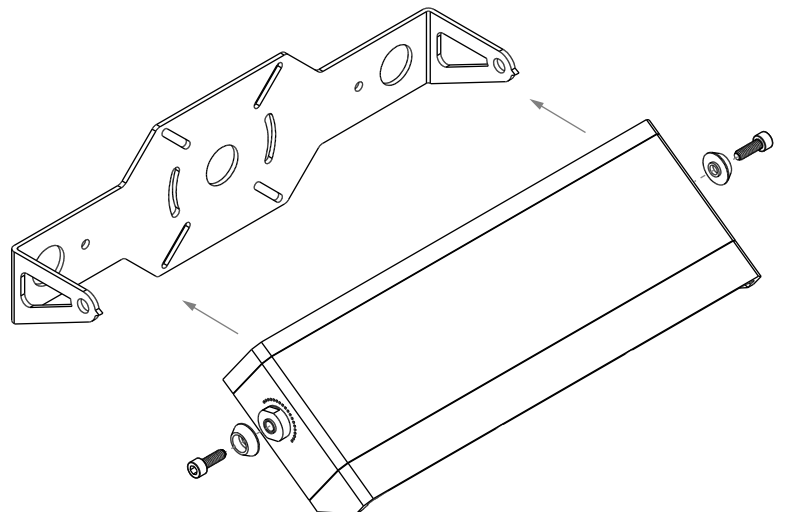
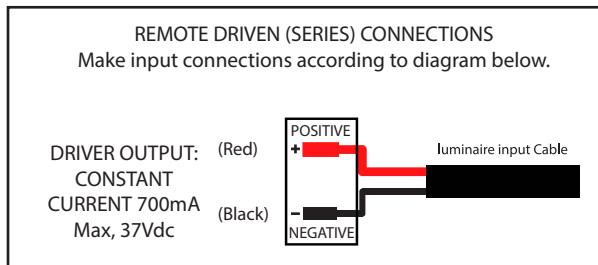
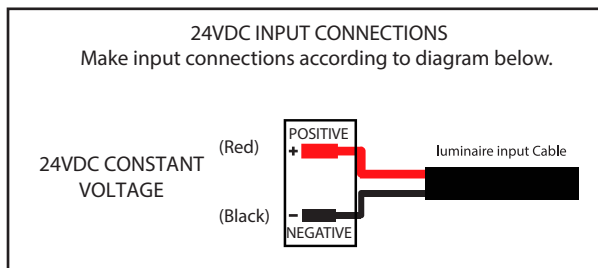
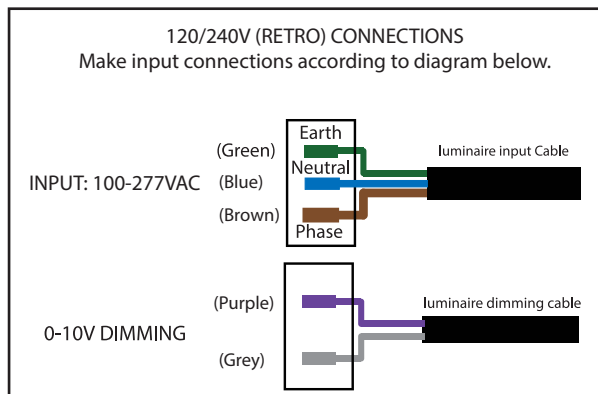
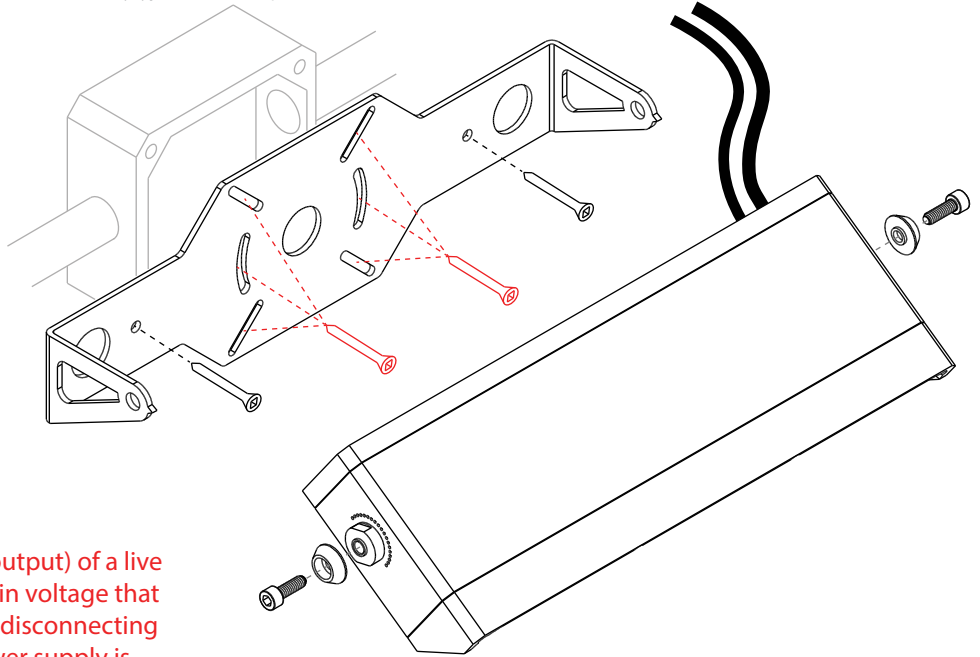

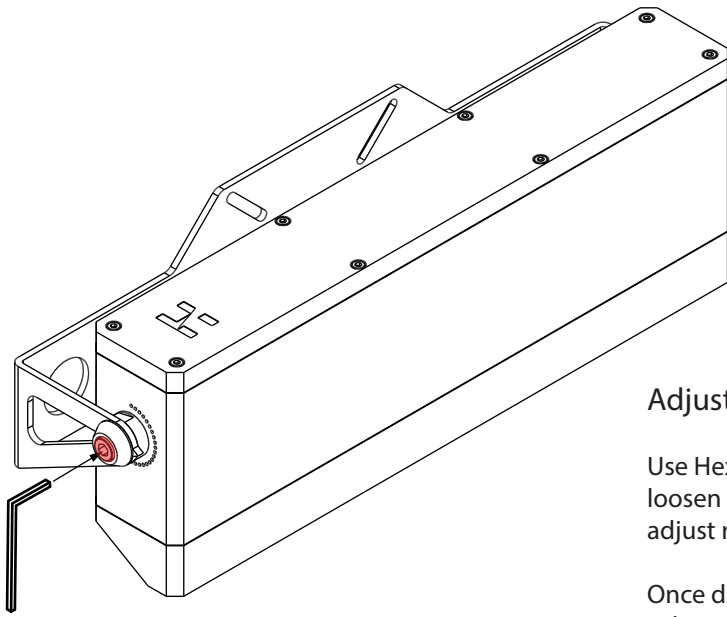

Adjusting Head position.

Use Hex (allen) key provided to loosen indicated screws to adjust rotation and head angle.

Once desired positioning is achieved tighten screws to lock in place

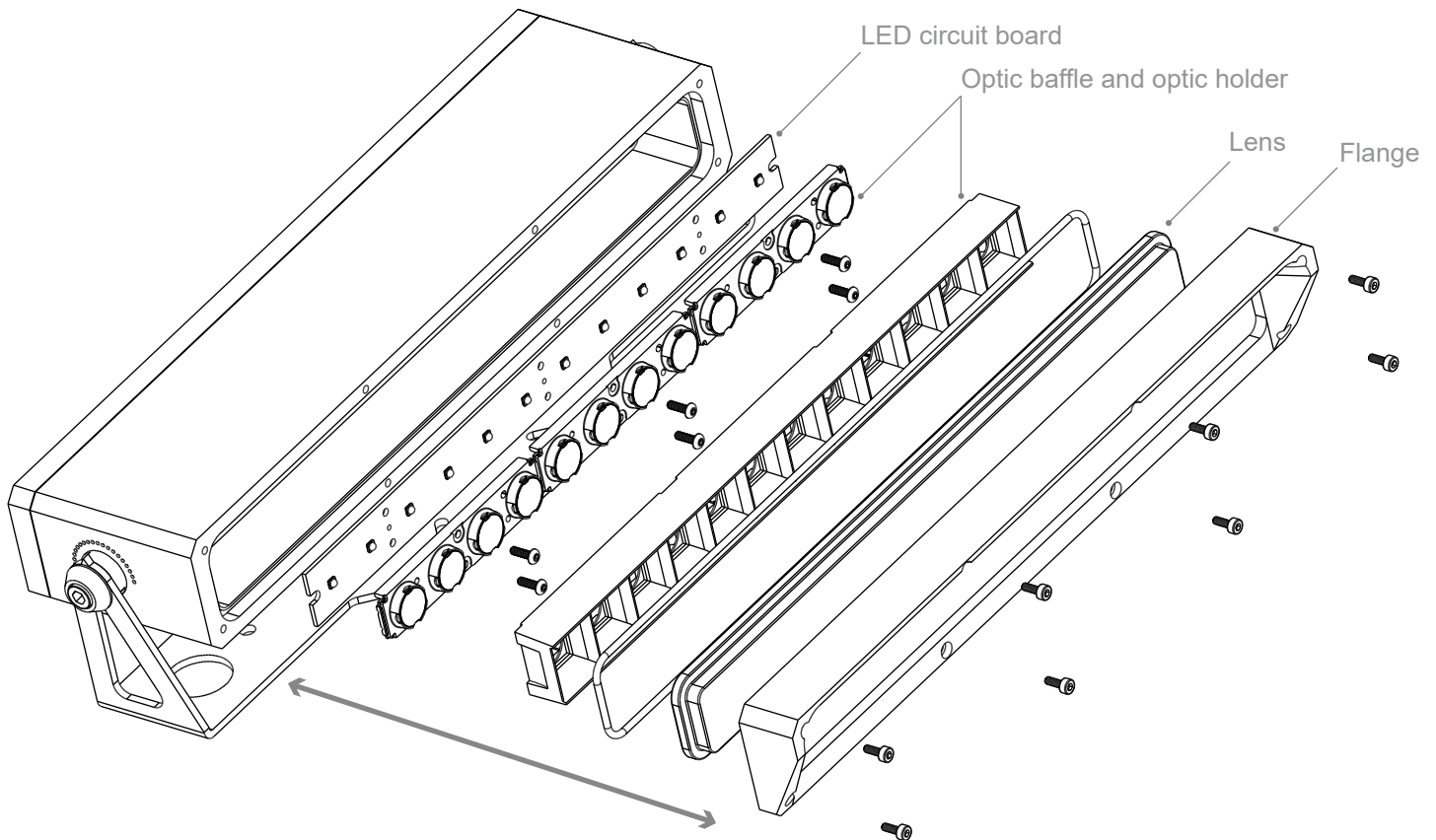
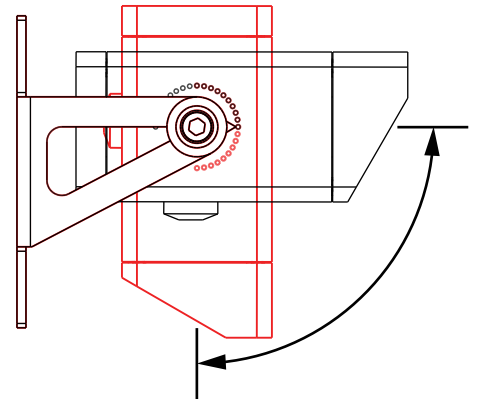

LED replacement

Undo 8 face plate screws. Remove face plate and lens. Remove black optic baffle and unscrew optic holder. Pay close attention to component order. The LED circuit board can now be changed. Reverse action to seal making sure components are replaced in correct order. Incorrect order can lead to failure of LED and/or leaking. Please ensure no dirt or grit is present around lens or gasket.

Do not water blast/jet wash this fixture under any circumstance