

Copper Pathlyte (CUL9) Specification Sheet

Project Name:	Location:	MFG: Philips Hadco
Fixture Type:	Catalog No.:	Qty:

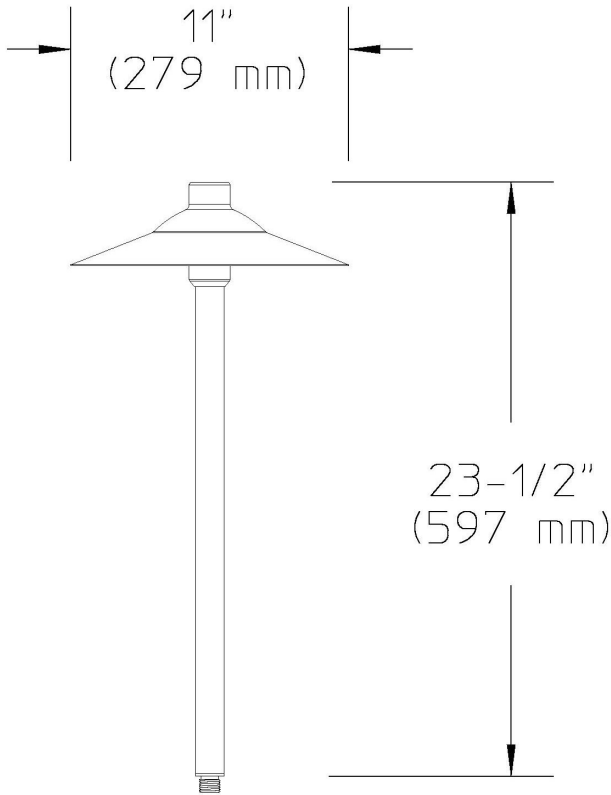

Ordering Guide

Example: CUL9 S7 _

Product Code	CUL9	Copper Pathlyte	
Mounting	S7	Mounting Stake	*1
Finish	_	Natural Copper	*2

*1 Mounting stake option available only with Natural Copper Pathlyte.

*2 When ordering Natural Copper, product code will read as CUL9.

Spacing Chart

Specifications

HOUSING:

Spun solid copper roof with copper stem. Machined copper threaded adapter for tool-less relamping. 1/2" NPS male threads to screw onto accessory mounting stake or junction box, sold separately.

FINISH:

Natural Copper is bright polished, untreated copper. Color will age naturally to a fine dark copper patina.

OPTICAL ASSEMBLY:

Frosted tempered glass lens. Reflective white powdercoat on underside of roof.

LAMPING:

20W maximum T3 bi-pin lamp. Lamp is included with fixture. Lower wattage lamps are acceptable.

ELECTRICAL ASSEMBLY:

Bi-pin socket type (G4) with 250° C high temperature teflon coated wire leads. 12 Volt fixture is pre-wired with 3-ft pigtail of 18-2 AWG, 105° C, SPT-1W wire. Low voltage quick connector, catalog #LVC3 included for easy hook-up to the low voltage supply cable, not included. 12 Volt system requires remote transformer, not included.

WARRANTY:

Ten-year limited warranty.

CERTIFICATIONS:

ETL listed to U.S. safety standards for wet locations. cETL listed to Canadian safety standards for wet locations. Manufactured to ISO 9001:2008 Standards.

Height :

23 1/2" (597 mm)

Width:

11" (279 mm)

Copper Pathlyte (CUL9) Specification Sheet

Project Name:	Location:	MFG: Philips Hadco
Fixture Type:	Catalog No.:	Qty:

Max. Weight:
4.45 lb

