

Bridge Recessed Wavestream

WARNING: Before starting any work ensure that all sources of power are turned off. All work must meet local/national electrical codes and be performed by a certified electrician.

1. REMOVING FIXTURE FROM PACKAGING

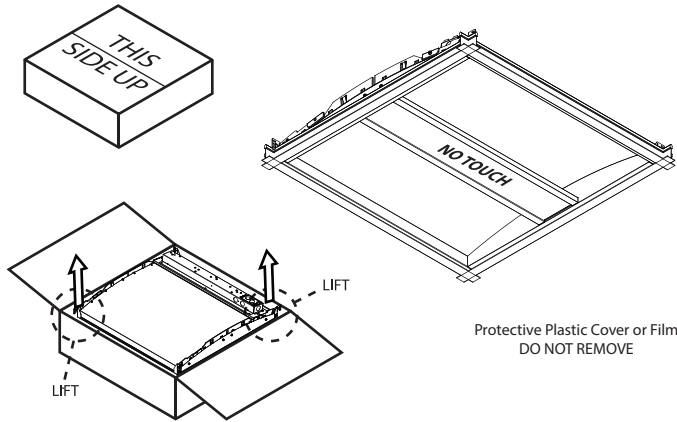

- A. Ensure "THIS SIDE UP" is visible and packaging is oriented in the designated direction.
 - B. Using CLEAN work gloves, carefully lift fixture out of packaging materials while holding on to opposite ends of fixture.
 - C. Plastic lens cover must remain on fixture until construction debris is no longer present.
- NOTE: AVOID CONTACT WITH LENSES**

2. INSTALLING FIXTURE TO GRID

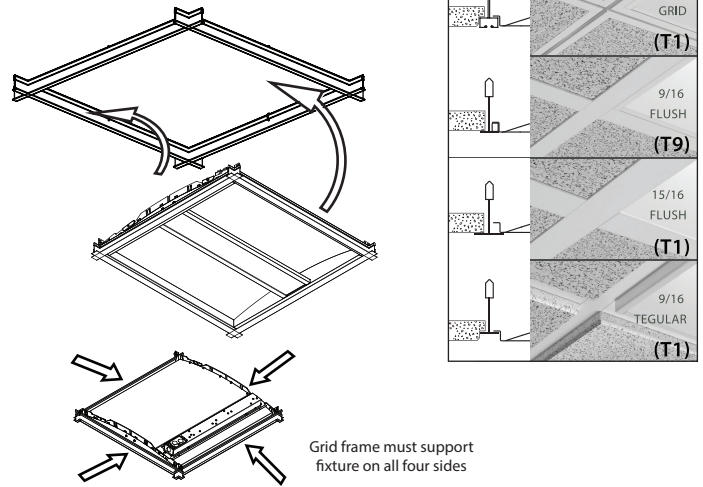

- A. Gently rotate fixture housing and angle into ceiling grid.
- B. Rest fixture inside the center of the Ceiling grid prior to securing tabs.
- C. Ensure all fixtures are oriented in the same direction or as intended by others.

3. SECURING FIXTURE TO GRID 4. MAKING POWER CONNECTION

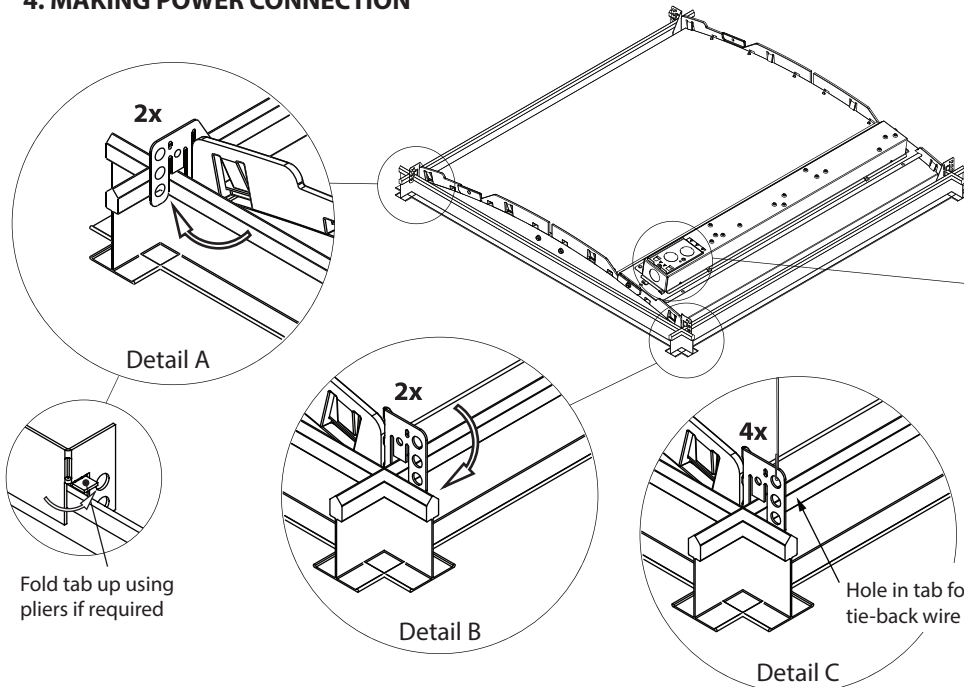

- A. Bend tabs as shown in Detail A and Detail B. Fold two (2) tabs in one direction and the other two (2) in the other to align with all four sides of the grid.
- B. If required, fold tab as shown in Detail A for taller grid types.
- C. After securing tabs to grid frame, tie back fixture to structure using holes provided in each tab shown in Detail C required per local code.
- D. All four (4) integral fixture tabs may be bent and fastened to the grid using sheet metal screws for additional support (Detail D). Evaluated to Security of Clips testing under UL 1598 testing requirements.
- E. Remove electrical access plate and remove necessary knockouts from access plate for attachment of electrical supply cable (Detail E). Make necessary wiring connections to driver AC line input and optional DALI or 0-10V dimming circuits. Replace electrical access plate and snap securely into place. If required, install optional screw to lock the access plate closed. Note: A second wire knockout is provided for daisy-chain wiring additional fixtures.

ATTENTION

Standard Access Plate

Installation

Grounding conductor (if insulated) to be stripped min. 1". Insert end of wire into small hole. Wrap wire under and around head of screw counter-clockwise (as illustrated). Tighten screw.

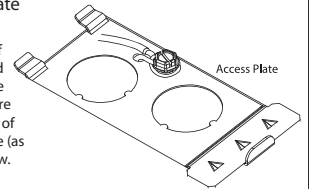

Flex Installation

Step 1. To insert access plate, rotate until leading end is inside the wireway (see A).
Step 2. Fold into horizontal position and slide forward into locking position.

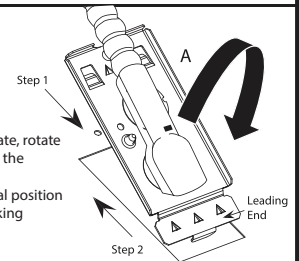

Detail E

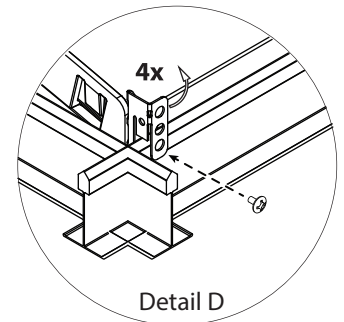

Detail D

Bridge Recessed Wavestream

WARNING: Before starting any work ensure that all sources of power are turned off. All work must meet local/national electrical codes and be performed by a certified electrician.

6. FINAL LUMINAIRE PREP

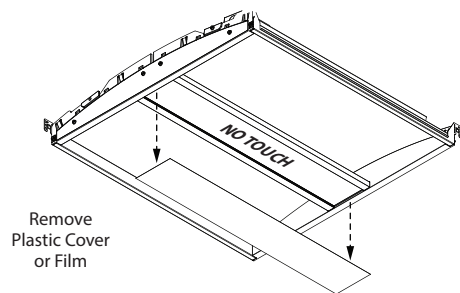

Remove Plastic Cover or Film

A. The luminaire is shipped with a protective cover and must remain installed on the fixture until all building construction and cleanup is complete. Once cleanup is complete, simply remove protective cover and recycle.

7. FIXTURE MAINTENANCE / CLEANING

Always follow recommended cleaning and handling procedures when cleaning the WaveStream™ lens. It can be permanently damaged if cleaned or handled improperly.

Before cleaning a WaveStream™ lens, take time to inspect the surfaces carefully in order to determine the type and severity of the contaminants. The process of cleaning the lens can result in damage to the optical surface if repeated multiple times.

For WaveStream™ lens with multiple contaminants, the order in which they are removed can be important. For instance, if a WaveStream™ lens is contaminated with oil and dust, it is possible that wiping the oil off first will scratch optical surface as the dust is dragged along the surface by the wipe.

8. BLOWING OFF THE SURFACE OF AN OPTIC

Dust and other loose contaminants should be blown off before any other cleaning technique is employed. Using compressed air over the entire lens is recommended to prevent static buildup.

When using compressed air, hold the can upright throughout the procedure. Also, start the flow of air with the nozzle pointed away from the lens. Hold the can approximately 6" from the optic and use short bursts. Move the nozzle of the compressed air can over the optic with the nozzle at a grazing angle to the optical surface in a constant one-way direction. Due to the non-contact and solvent free nature of this cleaning method, it should be used as a first step in cleaning all optics.

9. ADDITIONAL CLEANING METHODS

Fingerprints and large dust particles can be removed by gently wiping the surface with a clean microfiber cloth, if additional cleaning is required a mild solution of distilled water and Dawn® dish soap (between 1:20 and 1:10 parts Dawn to distilled water, respectively) could be used to wash the lens. The WaveStream™ lens should not remain wet any longer than necessary to remove the contaminants. Dry off surface with deionized air. Avoid pooling of water as that tends to leave streaks on the optical surface. This method is only recommended as a last resort as it increases the risk of damaging the lens.

Notes:

- Avoid any organic solvents. In addition, avoid any cleaning products including ammonia, ketones, window cleaners, or other alcohol based cleaners and solvents containing thinners, acetone, benzene and tetrachloride.

WARNING:

RISK OF FIRE, ELECTRICAL SHOCK, CUTS AND OR OTHER CASUALTY HAZARDS. THIS PRODUCT MUST BE INSTALLED IN ACCORDANCE WITH THE APPLICABLE INSTALLATION CODE BY A PERSON FAMILIAR WITH THE CONSTRUCTION AND OPERATION OF THE PRODUCT AND THE HAZARDS INVOLVED. COOPER LIGHTING SOLUTIONS ASSUMES NO RESPONSIBILITY FOR CLAIMS BROUGHT ABOUT BY IMPROPER OR CARELESS INSTALLATION OR HANDLING OF THIS PRODUCT.

ATTENTION RECEIVING DEPARTMENT:

NOTE ACTUAL FIXTURE DESCRIPTION OF ANY SHORTAGE OR NOTICEABLE DAMAGE ON DELIVERY RECEIPT. FILE CLAIM FOR COMMON CARRIER (LTL) DIRECTLY WITH CARRIER. CLAIMS FOR CONCEALED DAMAGE MUST BE FILED WITHIN 15 DAYS OF DELIVERY. ALL DAMAGED MATERIAL, COMPLETE WITH ORIGINAL PACKING MUST BE RETAINED



CAUTION

Edges may cut. Handle with care



CAUTION

Risk of burn. Disconnect power and allow fixture to cool before changing bulb or handling fixture.



WARNING

Risk of Fire and Electric Shock. If not qualified, consult an electrician.

NOTICE: GREEN GROUND SCREW PROVIDED IN PROPER LOCATION. DO NOT RELOCATE

NOTICE: IF SUPPLY WIRES ARE LOCATED WITHIN 3 INCHES OF BALLAST, USE WIRE RATED FOR AT LEAST 90°C (194°F).

