

### Divide Suspended Wavestream 4', 8', CONTINUOUS

**WARNING:** Before starting any work ensure that all sources of power are turned off. All work must meet local/national electrical codes and be performed by a certified electrician.

#### 1. REMOVING FIXTURE FROM PACKAGING

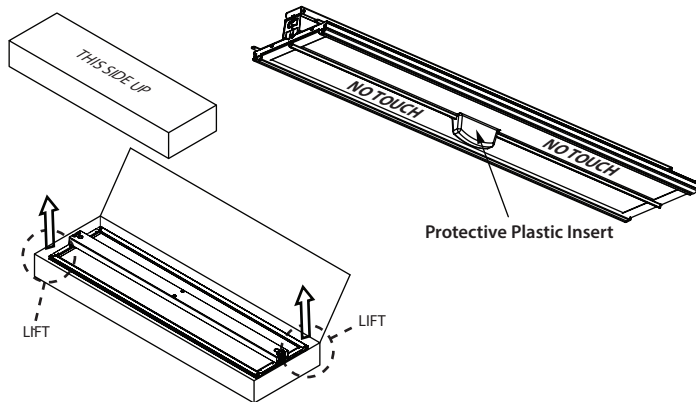

- A. Ensure "THIS SIDE UP" is visible and packaging is oriented in the designated direction.
  - B. Using CLEAN work gloves, carefully lift fixture out of packaging materials while holding on to opposite ends of fixture.
  - C. Plastic lens cover must remain on fixture until construction debris is no longer present.
- NOTE: AVOID CONTACT WITH LENSES**

#### 2. INSTALLING AIRCRAFT CABLES

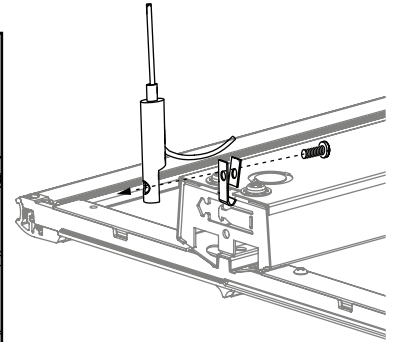
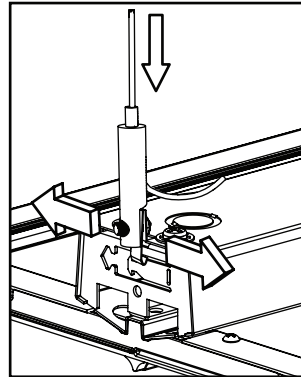

- A. Slide clip into fixture end and secure adjuster to clip. Insert aircraft cable into adjuster to desired length. Press down on adjuster to release cable. Repeat on opposite end.

#### 3. GENERAL MOUNTING

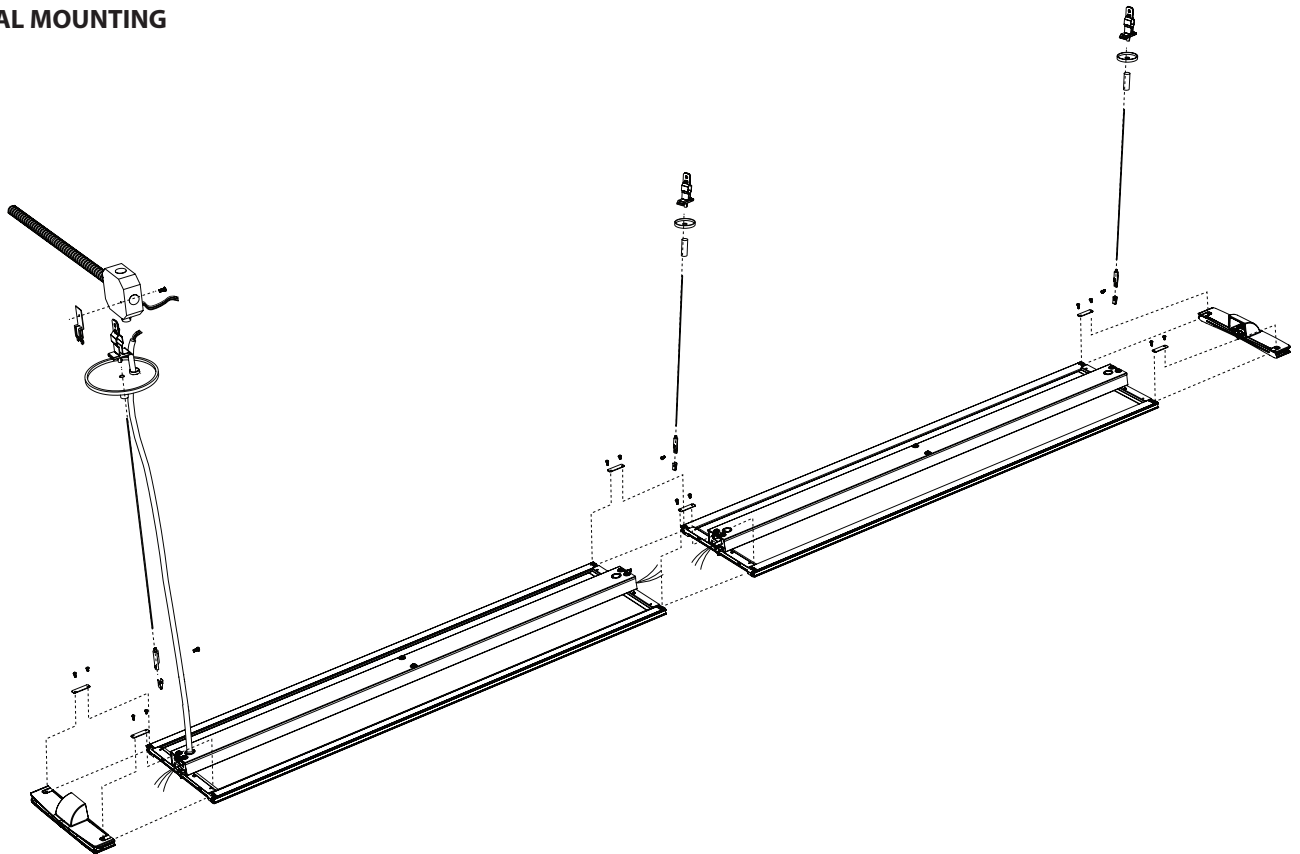

REFER TO MOUNTING INSTALL SHEETS FOR APPROPRIATE MOUNTING METHOD:  
T-GRID  
JUNCTION BOX CEILING  
JUNCTION BOX STRUCTURE

Not all options available. Please consult your Cooper Lighting Solutions Representative for availability. Specifications and Dimensions subject to change without notice.

### Divide Suspended Wavestream 4', 8', CONTINUOUS

**WARNING:** Before starting any work ensure that all sources of power are turned off. All work must meet local/national electrical codes and be performed by a certified electrician.

#### 4. MOUNT SPACING

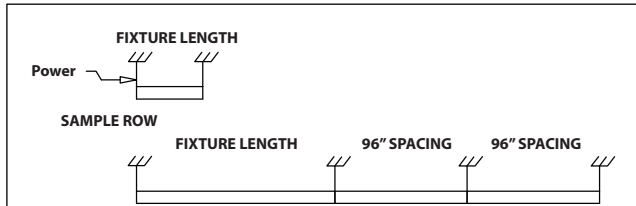

\*For continuous rows see joining sheet.

#### 5. POWER DROPS / KNOCK-OUTS

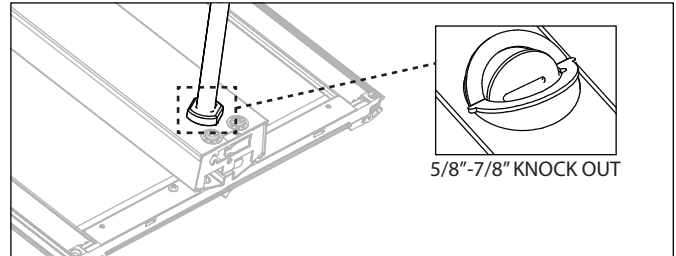

Break off appropriate KO, slide power cord through KO opening, then secure power cord with strain relief.

Note: Location of the KO's varies depending on fixture

#### 6. JOINING

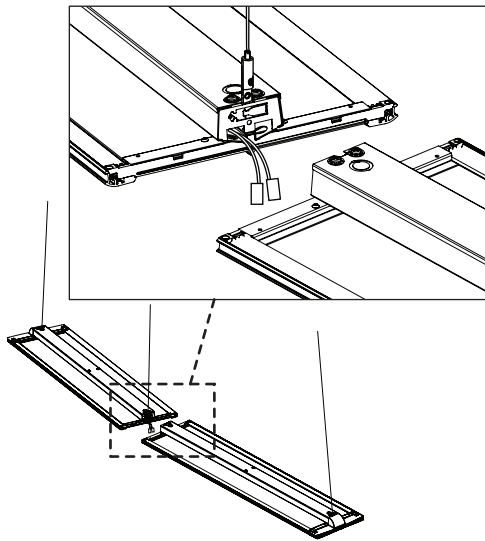

**A.** Install first fixture with two AC cable assemblies, then second fixture with one additional cable.

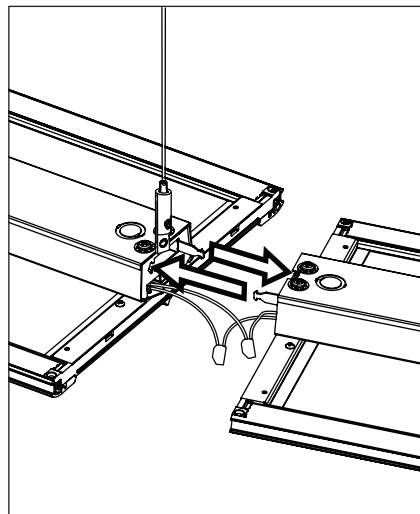

**B.** Bend out tapered aligning tabs and fit into aligner slots. (Fixture 2 is now supported by fixture 1 at the joint.)

**C.** Make electrical connections.

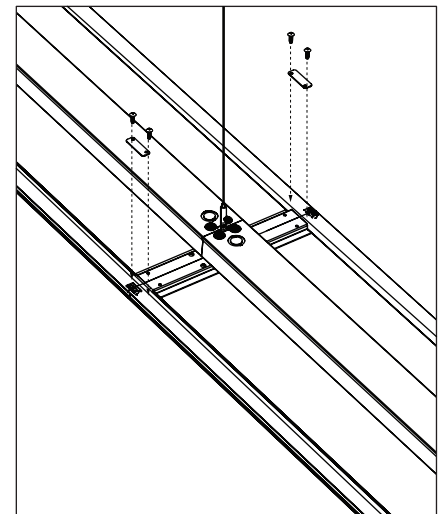

**D.** Tuck wires into wire cavity, slide both fixtures together.

**E.** Secure fixtures using two included mounting plates and provided hardware.

#### 7. END CAPS

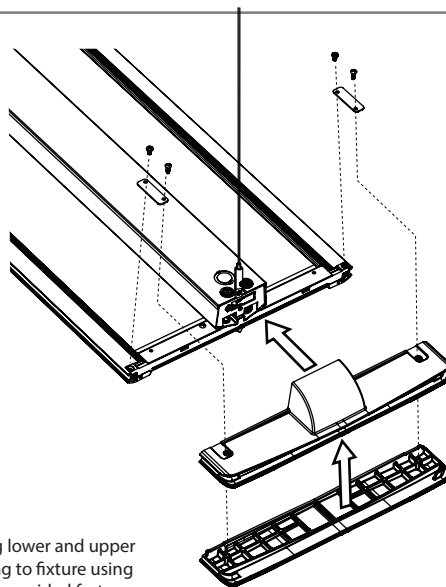

**A.** Attach END CAPS by placing lower and upper end caps together, and securing to fixture using included mounting plates and provided fasteners.

#### 8. FINAL LUMINAIRE PREP

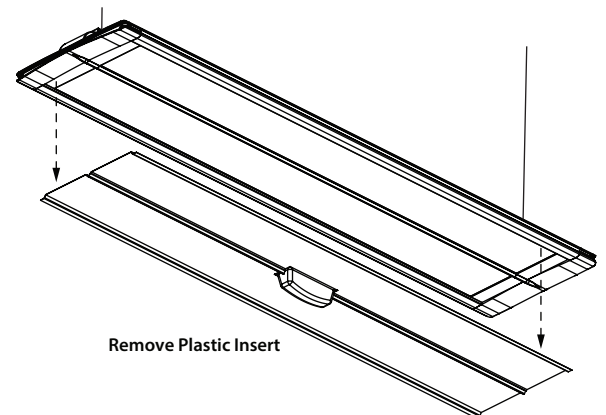

**A.** The luminaire is shipped with a protective cover and must remain installed on the fixture until all building construction and cleanup is complete. Once cleanup is complete, simply remove protective cover and recycle.

Not all options available. Please consult your Cooper Lighting Solutions Representative for availability. Specifications and Dimensions subject to change without notice.

### Divide Suspended Wavestream 4', 8', CONTINUOUS

**WARNING:** Before starting any work ensure that all sources of power are turned off. All work must meet local/national electrical codes and be performed by a certified electrician.

THIS SPACE INTENTIONALLY LEFT BLANK

#### 10. FIXTURE MAINTENANCE / CLEANING

Always follow recommended cleaning and handling procedures when cleaning the WaveStream™ lens. It can be permanently damaged if cleaned or handled improperly.

Before cleaning a WaveStream™ lens, take time to inspect the surfaces carefully in order to determine the type and severity of the contaminants. The process of cleaning the lens can result in damage to the optical surface if repeated multiple times.

For WaveStream™ lenses with multiple contaminants, the order in which they are removed can be important. For instance, if a WaveStream™ lens is contaminated with oil and dust, it is possible that wiping the oil off first will scratch the optical surface as the dust is dragged along the surface by the wipe.

#### 11. BLOWING OFF THE SURFACE OF AN OPTIC

Dust and other loose contaminants should be blown off before any other cleaning technique is employed. Using compressed air over the entire lens is recommended to prevent static buildup.

When using compressed air, hold the can upright throughout the procedure. Also, start the flow of air with the nozzle pointed away from the lens. Hold the can approximately 6" from the optic and use short bursts. Move the nozzle of the compressed air can over the optic with the nozzle at a grazing angle to the optical surface in a constant one-way direction. Due to the non-contact and solvent-free nature of this cleaning method, it should be used as a first step in cleaning all optics.

#### 12. ADDITIONAL CLEANING METHODS

Fingerprints and large dust particles can be removed by gently wiping the surface with a clean microfiber cloth. If additional cleaning is required a mild solution of distilled water and Dawn® dish soap (between 1:20 and 1:10 parts Dawn to distilled water, respectively) could be used to wash the lens. The WaveStream™ lens should not remain wet any longer than necessary to remove the contaminants. Dry off surface with deionized air. Avoid pooling of water as that tends to leave streaks on the optical surface. This method is only recommended as a last resort as it increases the risk of damaging the lens.

Notes:  
• Avoid any organic solvents. In addition, avoid any cleaning products including ammonia, ketones, window cleaners, or other alcohol based cleaners and solvents containing thinners, acetone, benzene and tetrachloride.

### WARNING:

RISK OF FIRE, ELECTRICAL SHOCK, CUTS AND OR OTHER CASUALTY HAZARDS. THIS PRODUCT MUST BE INSTALLED IN ACCORDANCE WITH THE APPLICABLE INSTALLATION CODE BY A PERSON FAMILIAR WITH THE CONSTRUCTION AND OPERATION OF THE PRODUCT AND THE HAZARDS INVOLVED. COOPER LIGHTING SOLUTIONS' ASSUMES NO RESPONSIBILITY FOR CLAIMS BROUGHT ABOUT BY IMPROPER OR CARELESS INSTALLATION OR HANDLING OF THIS PRODUCT.

#### ATTENTION RECEIVING DEPARTMENT:

NOTE ACTUAL FIXTURE DESCRIPTION OF ANY SHORTAGE OR NOTICEABLE DAMAGE ON DELIVERY RECEIPT. FILE CLAIM FOR COMMON CARRIER (LTL) DIRECTLY WITH CARRIER. CLAIMS FOR CONCEALED DAMAGE MUST BE FILED WITHIN 15 DAYS OF DELIVERY. ALL DAMAGED MATERIAL, COMPLETE WITH ORIGINAL PACKING MUST BE RETAINED



Edges may cut.  
Handle with care



Risk of burn. Disconnect power and allow fixture to cool before changing bulb or handling fixture.



Risk of Fire and Electric Shock. If not qualified, consult an electrician.

NOTICE: GREEN GROUND SCREW PROVIDED IN PROPER LOCATION. DO NOT RELOCATE

NOTICE: IF SUPPLY WIRES ARE LOCATED WITHIN 3 INCHES OF BALLAST, USE WIRE RATED FOR AT LEAST 90°C (194°F).

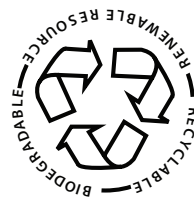

Not all options available. Please consult your Cooper Lighting Solutions Representative for availability. Specifications and Dimensions subject to change without notice.