

INSTALLATION INSTRUCTIONS

VISION FLOOD

12/29/03

IMI-512

IMPORTANT: Read carefully before installing fixture. Retain for future reference.

General: Upon receipt of fixture thoroughly inspect for any freight damage, which should be brought to the attention of the delivery carrier. Compare the catalog description listed on the packing slip with the fixture label on the housing to assure you have received the correct merchandise.

Safety: This fixture must be wired in accordance with the national electrical code and applicable local codes and ordinance. Proper grounding is required to insure personal safety. Carefully observe grounding procedure under installation section. All work should be done by a qualified electrician.

WARNING: Make certain power is OFF before starting installation or attempting any maintenance.

Color Filter and Filter Aperture Kit

1. To attach the Aperture Kit to the Vision Flood door, first remove the filter.
2. Locate the Aperture over and into the glass recess of the door (make sure the four Aperture Clips are loose when first placing the Aperture).
3. Tighten the four Aperture Clip Screws while making sure each one is engaged between the glass of the door and the door (biting into the door/glass gasket).
4. To install or change the color filter, remove the two screws that hold the cover to the Aperture. Next, remove the cover and the filter. Finally, replace the cover and screws after the filter is in place.

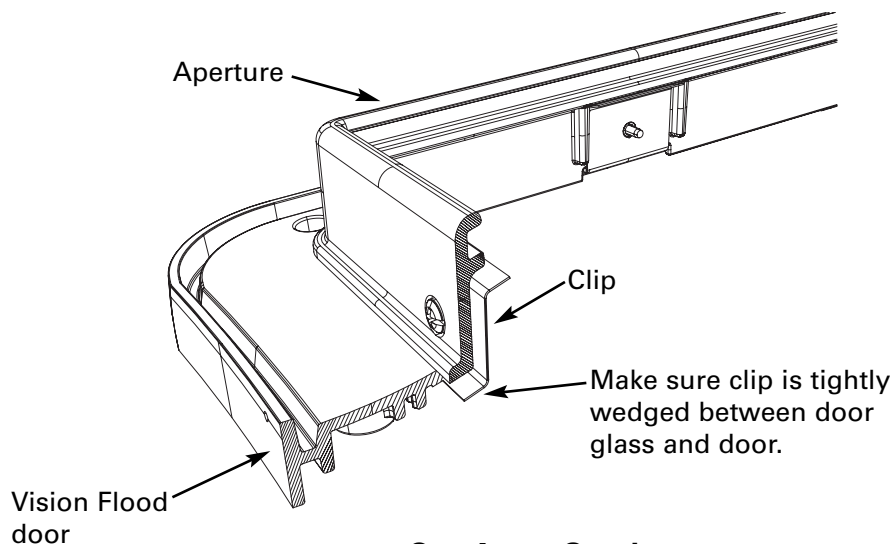
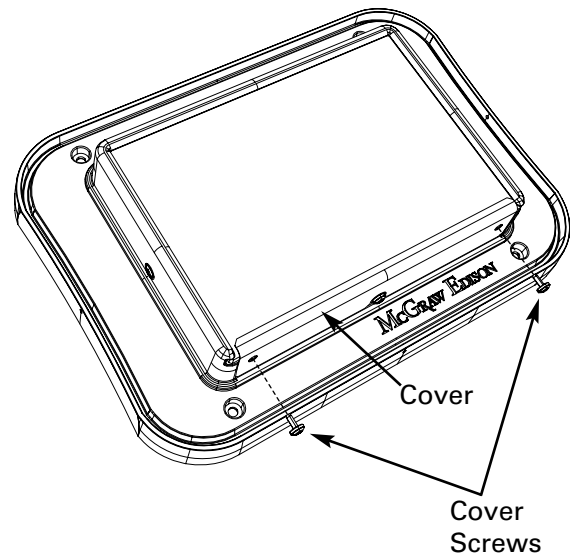

These instructions do not claim to cover all details or variations in the equipment, procedure, or process described, nor to provide directions for meeting every possible contingency during installation, operation or maintenance. When additional information is desired to satisfy a problem not covered sufficiently for user's purpose, please contact your nearest representative.