

CHLORIDE

by Signify

Exit/Emergency

CD series

Dust-proof remote fixtures

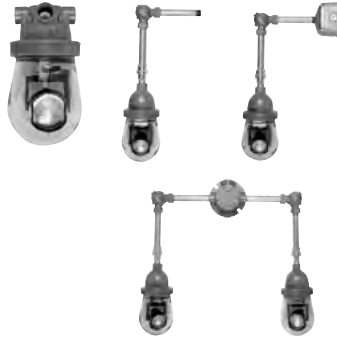

Project: _____
Location: _____
Cat.No: _____
Type: _____
Lamps: _____ Qty: _____
Notes: _____

Example: CDEM1

CD

Series

CD – Combustible Dust
Emergency Lighting

Fixture Type

SC – Ceiling Mount
EM – Emergency Unit
SW – Single Wall Remote
DW – Double Wall Remote

Voltage

1 – 6 VDC, 12 W²
2 – 12 VDC, 12 W²
3 – 120 VAC¹

Accessories (Order Separately)

WGG – Wire Guard for Globe Only

Footnotes

- ¹ Uses (1) 150 W A19 medium base lamp (not included).
² Uses (1) 6 or 12 VDC W halogen lamp (included).

codes and standards

- Suitable for use in Class II, Division 1 & 2, Groups E F & G, and Class III areas
- Temperature performance rating is T3B
- Supply wire rating 150°C

construction

- Constructed of corrosion-resistant, cast aluminum alloy with an epoxy polyester finish.
- Ceiling mount fixture and single wall remote have universal junction box with four tapped holes for 3/4" rigid conduit (three close-up plugs included).
- Double wall remote has junction box with two tapped holes for 3/4" rigid conduit (one close-up plug provided).
- CDEM1 (2) fixture is designed for direct mounting to the IXN50 battery unit (IXN50 unit not included).

electronics

- 120 VAC voltage configuration is ideal when using an AC inverter/UPS lighting system.
- Remote mount from an area located outside the hazardous area via a 6 VDC or 12 VDC battery unit.

lamps

- Illumination is accomplished with halogen or incandescent lamps that are adjustable to 360°.

warranty

- Five full years on electronics and unit (excluding lamps).



CD Dust-proof remote fixtures

dimensions

