

ATLITE RIVAL SERIES INSTALLATION INSTRUCTIONS FOR NEW YORK LED COMBINATION EMERGENCY EXIT LIGHT

IMPORTANT SAFEGUARDS

When using electrical equipment, basic safety precautions should always be followed including the following:

READ AND FOLLOW ALL SAFETY INSTRUCTIONS

- Do not use outdoors.
- Do not let power supply cords touch hot surfaces.
- Do not mount near gas or electric heaters.
- Equipment should be mounted securely in locations and at heights where it will not be readily subjected to tampering by unauthorized personnel.
- The use of accessory equipment and replacement parts not recommended by the manufacturer may cause an unsafe condition.
- Do not use this equipment for other than its intended purpose.
- The AC voltage rating of this equipment is specified on the product label. Do not connect equipment to any other voltage.

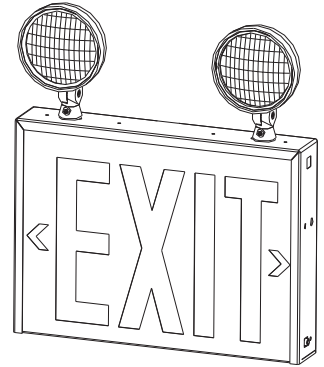

SAVE THESE INSTRUCTIONS!

IMPORTANT:

- When re-lamping use only lamps specified by the manufacturer. Using other lamp types may result in transformer damage or cause unsafe conditions.
- Battery in this unit may not be fully charged. After electricity is hooked up to the unit, let the battery charge up for at least 24 hours. Then normal operation of this unit should then take effect.

INSTALLATION:

Back Mounting —

1. Slide out the front exit panel face plate and lens/ filter by removing the screw on the bottom of the unit.
2. Remove internal metal reflector plate by removing the (2) screws.
3. Determine which mounting holes will be used to mount the fixture to J-BOX and then punch out proper K/Os from the K/O pattern on the back panel of the housing.
4. There are two additional KEY HOLE slots located on the top of the unit. These holes must be used when the unit is mounted to the wall.
5. Connect AC supply wires to fixture input wires. Black is for 120V; Red is for 277V; White is for Neutral. Insulate the unused red or black wire.
6. Install and connect the battery.
7. Replace the internal metal reflector and secure unit with the (2) screws.
8. Reinsert the front exit panel and red lens/ filter and secure with screw.

OPTION: ADDITIONAL 3rd LIGHTING HEAD. If required this head could be mounted in between the two existing heads on the unit. This could be done before, during or after the unit's installation. The procedure is described in the following steps.

1. Punch out the square mounting hole on the top of the unit.
2. Mount the head securely with the included nut (Fig. 1).
3. Connect the yellow and violet wires coming from the circuit board (labeled 'remote wires') to the yellow and violet wires on the lamp head using wire nuts or any other prescribed method.

OPERATION:

1. To test the equipment, depress the TEST switch. The charge (LED) indicator will turn OFF and the emergency lights will illuminate. Exit section will remain illuminated.
2. Once you release the TEST switch the emergency lights will turn OFF and the charge (LED) indicator will illuminate.
3. The automatic charger will return into action, charging the battery and trying to maintain it in a fully charged state. **NOTE:** Allow the battery to charge for a minimum of 24 hrs after installation or after a power failure before conducting a 90-minute test (see TESTING section). **CAUTION:** This equipment is furnished with a sophisticated solid state transfer switch which will automatically disconnect the emergency lights from the battery if the battery has been discharged to the end of its useful output.

NOTE:
LAMP HEAD
INSTALLATION
INSTRUCTION

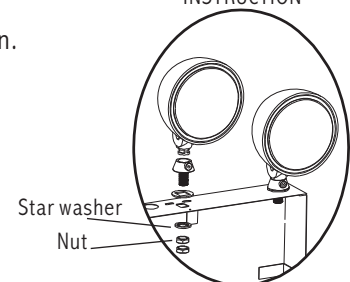

Fig 1

WARNING: Unused wires must be capped using enclosed wire nuts.

MAINTENANCE:

CAUTION: Always turn OFF AC power to the equipment before servicing. Servicing should be performed only by a qualified service technician. Only manufacturer SUPPLIED or APPROVED replacement parts must be used.

1. **BATTERY:** The battery supplied with this unit requires ZERO maintenance. However it should be tested periodically (see TESTING section) and replaced when it no longer operates the connected fixtures for the complete duration of a 30-second or 90-minute test. It has a life expectancy of 5-7 yrs when used in a normal ambient temperature of 72° F.
2. **OTHER:** Clean lenses and replace lamps as and when required.

TESTING:

Paragraph 31-1.3.7 of NFPA 101-1985, Life Safety Code requires that all emergency lighting equipment be functionally tested every 30 days for a minimum of 30 seconds and tested annually for full 90-minute duration. Written records of the testing are to be kept for examination by the authority having jurisdiction.

TROUBLESHOOTING:

1. The emergency lights DO NOT operate and
 - a. If the charge indicator light is OFF - Check that the circuit breaker for AC supply is ON.
 - b. If the charge indicator light is ON
 - Check that the battery is properly connected.
 - If remote lamps are connected to the equipment, then turn OFF the AC supply and disconnect the remote circuit wires from the equipment. Turn ON the AC supply and depress the test switch. If the local lamps (mounted on the equipment itself) come ON, then check the remote circuit for short or overload condition and correct as required. Reconnect the circuit wires and restore AC power.
 - If the local lamps don't turn ON after disconnecting the remote circuit wires, then replace battery.
2. Emergency lights are dim - Implies battery might not be fully charged. Allow battery to recharge for 24 hours and then re-test.
3. Remote lights are dim - Remote wire size is too small causing excessive voltage drop (more than the permitted 5%) and thus causing the lamps to illuminate with less intensity. Refer to STEP 4 of INSTALLATION section for more information.

NOTE: Please contact factory for help with other types of issues.

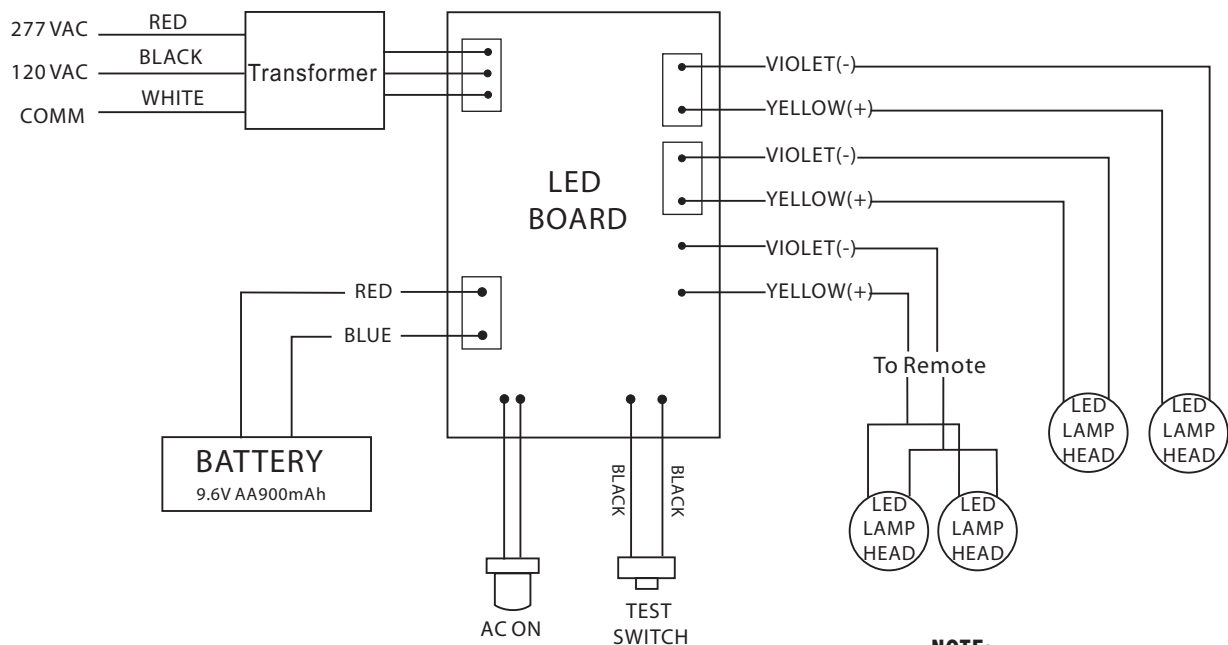

NOTE:

4 TOTAL LED LAMP HEADS MAX.
(INCLUDING REMOTE HEADS)

WARNING:

UNUSED WIRES MUST BE CAPPED USING ENCLOSED WIRE NUTS.