



WARNING

PLEASE READ ALL INSTRUCTIONS BEFORE ATTEMPTING INSTALLATION

1. All electrical work must conform to the National Electric Code (NEC) and all applicable local codes and ordinances.
2. Only qualified personnel shall install and maintain the luminaires. Mester recommends that a licensed electrician install and maintain the luminaire. Verify the safety of existing power distribution system before beginning installation. Failure to follow Operating Instructions may lead to death, Severe Injury, or Property Damage.
3. Fixtures must be grounded and installed in accordance with the National Electrical Code and all local codes. If you are not sure if your power system is grounded, DO NOT install the luminaire. Contact a licensed electrician for information on proper grounding methods as required by the electrical code. FAILURE TO FOLLOW THIS WARNING MAY LEAD TO DEATH, SEVERE INJURY, OR PROPERTY DAMAGE.
4. Turn off power and allow to cool before performing any electrical or control work. FAILURE TO FOLLOW THIS WARNING MAY LEAD TO DEATH, SEVERE INJURY, OR PROPERTY DAMAGE.
5. DO NOT make or alter any open holes in the luminaire. Do not modify the luminaire.
6. Risk of eye injury! Eye protection is required at all times during the installation, operation, and maintenance of the luminaire. The high intensity light produced by the luminaire can cause severe damage to the eye if viewed directly at close range. Avoid being in front of a luminaire that is on or wear suitable light blocking protective eyewear such as welding goggles. The luminaire should be positioned so that prolonged staring into the luminaire at a distance closer than 10m is not expected.
7. NEVER point the aiming laser at any person or animal as it can cause permanent damage to eyes. Use laser only for aiming fixtures as directed.
8. CAUTION - RISK OF FIRE.
9. This product is not available for several special environments, such as places with corrosive gas liquids or high pressure water vapor.
10. This luminaire is designed to operate in ambient temperatures ranging from -40°C to 55°C (-40°F to 131°F).

CAUTION WHEN USING THE LASER AIMING ASSEMBLY



Never look directly into the laser beam.

Installation Guide 1 (Default)

1. Secure visor on fixture with four PM5*8-SS screws (30-45 in-lbf (3.5 to 5 N-m)).
2. Loosen two CM4*25 screws from aiming assembly; attach the aiming assembly in the keyhole slots and tighten two screws (30-45 in-lbf (3.5 to 5 N-m)).
3. Drill appropriate knockout on the mounting structure according to the size of the mounting bracket.
4. Align the center hole of the horizontal aiming protractor and the mounting bracket and attach the horizontal aiming protractor to the mounting structure.
5. Set luminaire in place and install bolt, flat washers, spring washer and nut to securely fasten the fixture mounting bracket to the mounting structure (35-45 ft-lbf(47 to 60 N-m)). Do not fully tighten the hardware until the fixture is aiming, just make sure the fixture is secure.
6. Slightly loosen the fixture aiming screws just enough to allow the fixture to rotate and tilt. Use horizontal aiming protractor and aiming sights to locate fixtures depending on different lighting needs. After aiming is complete, tighten all bolts and screws including hex screws (26-33 ft-lbf (35 to 45 N-m)) and set screws (35-75 in-lbs (4-8 N-m)) on side of fixture and mounting hardware.
7. Set driver box on the mounting bracket so that the screw holes on the both sides of the drive box align with the mounting holes on the bracket and pay attention to the side of the drive output line to be facing up. Install screws (CM8*20), washer, and nut to securely fasten the box to the mounting bracket (35-75 in-lbs (4-8 N-m)). Driver box and light head must have matching power ratings. Do NOT install light head on a driver box that has a different power rating. Failure to properly match driver box and light head can damage the fixture.
8. Connect the driver output cable to light engine cable through the water proof terminal, Insert two parts of terminal together, tighten the screw, make sure it on a good water proof condition.
9. Remove one of the 1/2" screw plugs from the back of the driver box, then remove the driver box cover, pass the input wire through the cover (sufficiently long wire needed) and secure it with a metal waterproof connector (supplied by others). Make all necessary wiring connections, according to below wiring diagram, observing proper voltage and polarity.
10. Make sure that all wires are securely connected and that there are no exposed conductors, carefully push the wire into the junction box (Make sure wires do not get pinched), then reinstall the junction box bottom cover (35-75 in-lbf (4-8 N-m)).
11. Installation and service of luminaires should be performed by a qualified licensed electrician.

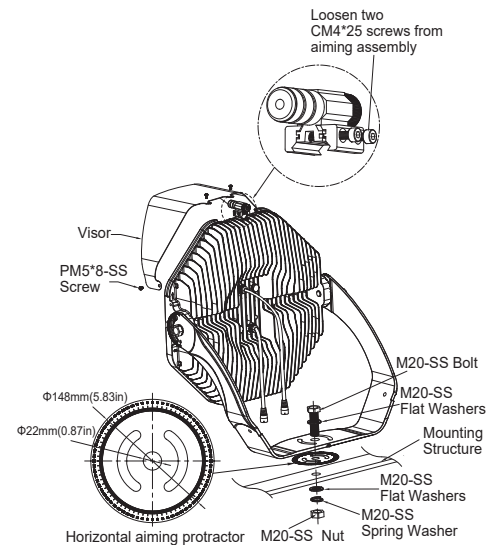

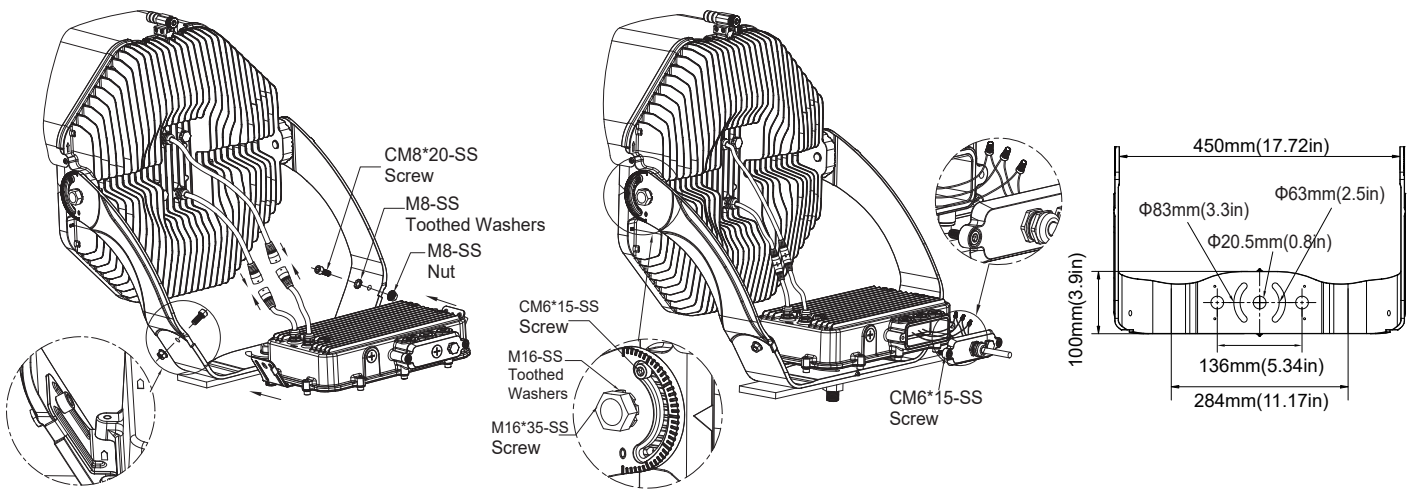

Installation Guide 2 (Option)

1. Secure the mount bracket plate on the mounting bracket with four KM4*12-SS screws (30-45 in-lbf (3.5 to 5 N-m)).
2. Secure visor on fixture with four PM5*8-SS screws (30-45 in-lbf (3.5 to 5 N-m)).
3. Secure the yoke adaptor on the mounting bracket with two bolts, spring washers and nuts (35-45 ft-lbf (47 to 60 N-m)), put the yoke adaptor on top of the 2-3/8" tenon, and lock it with the three 3/8 x 0.787 screws (10-15 ft-lbf (14 to 18 N-m)).
4. Loosen two CM4*25 screws from aiming assembly; attach the aiming assembly in the keyhole slots and tighten two screws (30-45 in-lbf (3.5 to 5 N-m)).
5. Slightly loosen the fixture aiming screws just enough to allow the fixture to rotate and tilt. Turn on the laser and using aiming assembly to aim the fixture to the proper point may according to the lighting design. After aiming is complete, tighten all bolts and screws including hex screws (26-33 ft-lbf (35 to 45 N-m)) and set screws (35-75 in-lbs (4-8 N-m)) on side of fixture and mounting hardware.
6. Set driver box on the mounting bracket so that the screw holes on the both sides of the drive box align with the mounting holes on the bracket and pay attention to the side of the drive output line to be facing up. Install screws (CM8*20), washer, and nut to securely fasten the box to the mounting bracket (35-75 in-lbs (4-8 N-m)). Driver box and light head must have matching power ratings. Do NOT install light head on a driver box that has a different power rating. Failure to properly match driver box and light head can damage the fixture.
7. Connect the driver output cable to light engine cable with the water proof terminal, Insert two parts of terminal together, tighten the screw, make sure it on a good water proof condition.
8. Remove one of the 1/2" screw plugs from the back of the driver box, then remove the driver box cover, pass the input wire through the cover (sufficiently long wire needed) and secure it with a metal waterproof connector (supplied by others).
9. Make all necessary wiring connections, according to below wiring diagram, observing proper voltage and polarity. Make sure that all wires are securely connected and that there are no exposed conductors, carefully push the wire into the junction box (Make sure wires do not get pinched), then reinstall the driver box bottom cover (35-75 in-lbs (4-8 N-m)).
10. Installation and service of luminaires should be performed by a qualified licensed electrician.

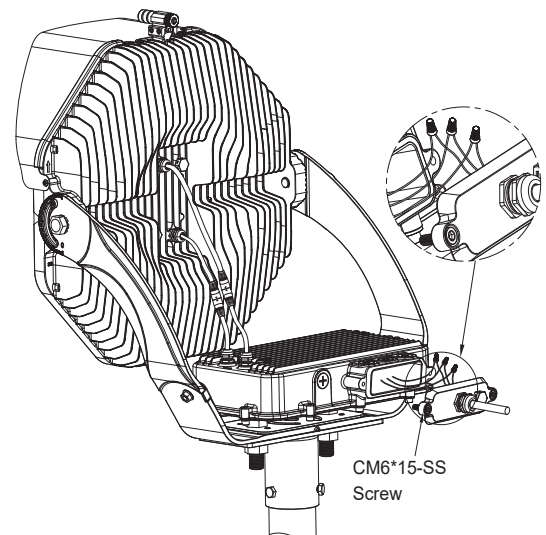
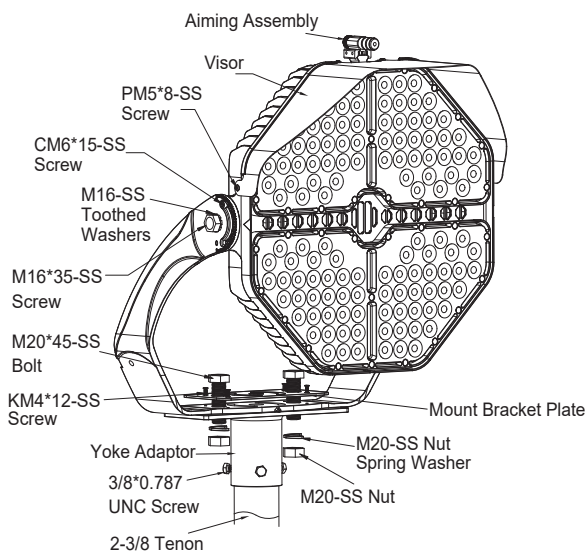

Orient –Tilt

The Orient angle refers to the direction of the fixture face in the Z plane. In other words, mount the fixture on the structure, but keep the mounting nut slightly loosened so that the entire fixture to spin about the mounting bolt. Set the luminaire Orient by rotating the fixture mounting bracket relative to the mounting structure.

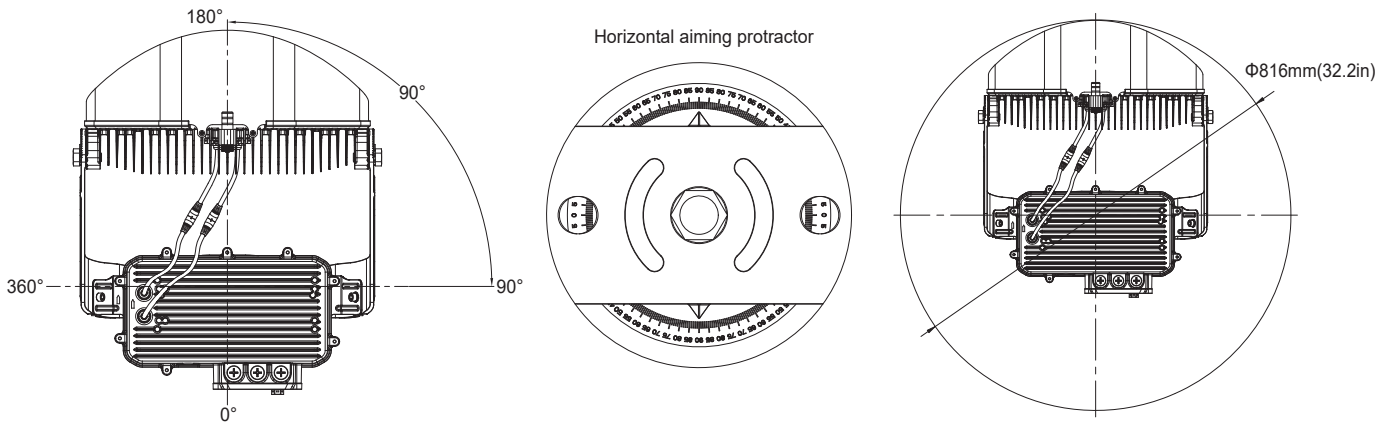

Tilt angle refers to the direction in which the fixture faces in the Y plane. When the luminaire is securely mounted on the structure so that the mounting bracket does not move, but the side hexagon and the mounting screw are loosened, the fixture may rotate upward in the mounting bracket. Set the tilt angle of the fixture by rotating the fixture housing relative to the fixture mounting bracket.

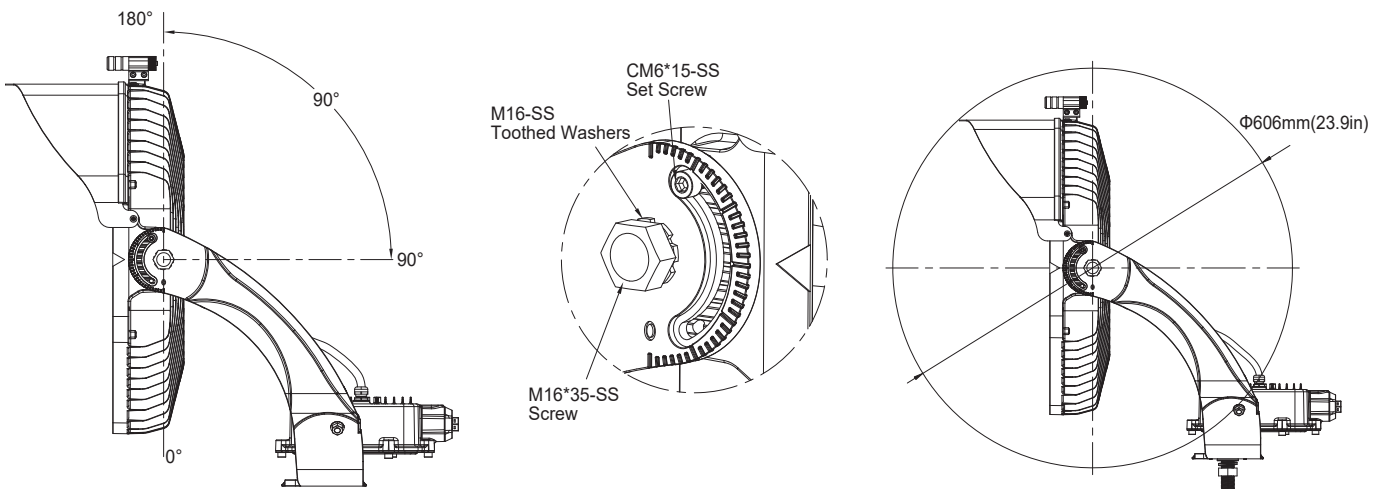

Note:

1. For replacement LED Assemblies and Drivers please contact MESTER Lighting for any replacement parts.
2. Contact your local distributor or agent to confirm parts availability prior to ordering replacement parts.







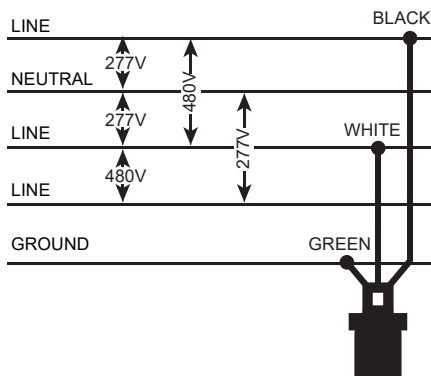

Electrical Connections

Power Wiring Connections

3-Phase Non-Grounding: 3Ø 277/480V



Accessories List

Diagram		Quantity	Diagram		Quantity
Battery		3 pcs	HM20*60-SS Bolt		1 pc
Laser aiming assembly		1 set (Two parts, aiming head and cover)	M20-SS Flat Washers		2 pcs
Hexagon key		2 pcs	M20-SS Spring Washer		1 pc
PM5*8 screws		4 pcs	M20-SS Nut		1 pc
Horizontal aiming protractor					1 pc