

Features & Benefits

Precision Die-Cast Aluminum Housing with Heat Dissipating Fins

Shock and Vibration Resistant

120 Degree Lens Guarantees Light Intensity and Light Uniformity

Motion Sensor Available for Maximizing Energy Savings

Superior Color Rendition Index Compared to HPS

Optional Emergency Function for Emergency Needs

UL Listed for Wet Location

5-Year Limited Warranty

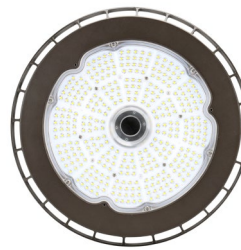

Mounting

Suitable for Hook or 3/4" conduit pendant.



Emergency Battery

16 W | 2000lm | 90min.

Motion Sensor

Optional motion sensor allow for security and energy saving.



Housing

Symmetrical design for consisten installed results. A large numbers of heat sinks for maximum heat dissipation, Combined with sensor detect added into the system, more energy would be saved and pretty less maintenance than MH technology.

Technical Parameters

Power	Light Output	Input	Operating Temperature	Efficacy
135W-200W	19,400 lm -29,800 lm	120-277V, 347/480V	-40°F- 131°F	Up to 149 lm/W

Color Temperature	CRI	Certifications	Motion Sensor	Driver
4000K, 5000K	70 CRI	UL/DLC	Bi-Level PIR Sensor	1-10V Dimming

Beam Angle	Mounting Options	Finish		
120°	Hook, Conduit	Dark Bronze, White		

Performance Data

4000K (70 CRI)		
LED Watts	Lumens	LPW
135W	19,400 lm	144 lm/W
175W	25,600 lm	146lm/W
200W	29,800 lm	149 lm/W

5000K		
LED Watts	Lumens	LPW
135W	19,400 lm	144 lm/W
175W	25,600 lm	146lm/W
200W	29,800 lm	149 lm/W

Ordering Information

Example: ALG-150W-50K-PM-T3

(Optional)

Model	Wattage	Voltage	CCT	Finish	Sensor
HBC04 High Bay HBC04 Series	135W 175W 200W	Blank 120-277V HV 347/480V	40K 4000K 50K 5000K	Blank Dark Bronze	M Motion Sensor EM Emergency Battery

Note:

1. 70W, 105W = Type 3 and Type 5 only
2. Pole Mount Includes Square & Round Pole Adapter
3. Mounting Adapters Sold Separately

Product Dimensions

Weight
 135W: 10.39 lb
 175W: 10.86 lb
 200W: 10.87 lb

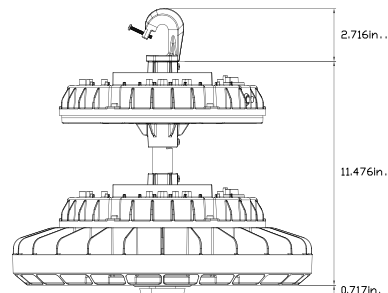
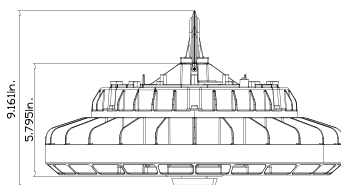

Weight
 135W: 15.16 lb
 175W: 15.73 lb
 200W: 15.84 lb

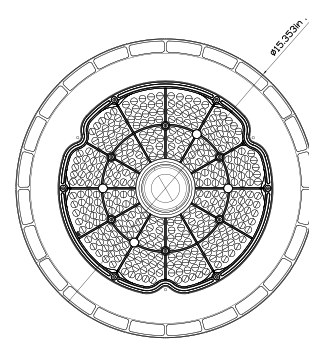
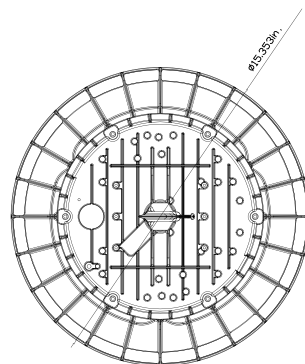

DLC Listed Models

System Watt	Voltage	CCT	DLC NO	DLC Classification
135W	120-277V	4000K	HBC04-135W-40K-[Blank]-[Blank,M,EM]	Premium
135W	120-277V	5000K	HBC04-135W-50K-[Blank]-[Blank,M,EM]	Premium
135W	347/480V	5000K	HBC04-135W-HV-50K-[Blank]-[Blank,M,EM]	Premium
175W	120-277V	5000K	HBC04-175W-50K-[Blank]-[Blank,M,EM]	Premium
175W	347/480V	5000K	HBC04-175W-HV-50K-[Blank]-[Blank,M,EM]	Premium
200W	120-277V	5000K	HBC04-200W-50K-[Blank]-[Blank,M,EM]	Premium
200W	347/480V	5000K	HBC04-200W-HV-50K-[Blank]-[Blank,M,EM]	Premium