



X9

Recessed Aluminum LED Edgelit Exit

STANDARD



OPTIONAL

ILLUMINATION

- Ultra bright, energy efficient, long life Red or Green LEDs.
- UV-stabilized ultra-clear acrylic edgelit panel provides consistent, uniform illumination.
- Double face utilizes factory installed silver or white mylar background panel.

ELECTRICAL

- Dual 120/277 voltage standard.
- Charge rate/power "ON" LED indicator light and push-to-test switch for mandated code compliance testing.
- 4.8V long life, maintenance-free, rechargeable NiCd battery (EM models only).
- Internal solid-state transfer switch automatically connects the internal battery to LED board for minimum 90-minute emergency illumination.
- Fully automatic solid-state, two rate charger initiates battery charging to recharge a discharged battery in 24 hours.

MOUNTING

- Compatible with drywall or drop ceiling mount installations. Bar hangers included.
- Wall mount capability optional.

HOUSING

- Premium-grade, extruded aluminum housing.
- Extruded aluminum trim assembly is easily detachable from below, providing accessibility for service or maintenance. Available in optional black or white powder-coated finishes.
- Self-adhesive Chevron appliques and guide template provided for directional indication.

OPTIONS

- WM: Allows for the unit to be wall recessed mounted.
- 2C-120V/2C-277V: Voltage-specific dual circuit option on the AC-only unit enables it to be connected to two different supplies at the same time.
- SDT: Self-diagnostic feature performs monthly, biannual, and annual tests to ensure reliable operation and meets electrical and life safety codes.
- USA: Substantial transformation assembly in the U.S. complies with "Assembled in the USA" under the Buy American Act.
- SPV: UL Listed for 208/220/240 Volt, 50/60Hz.
- Custom: Signs available with requested 'special' wording.

WARRANTY / LISTING

- Five year warranty on all electronics and housing. Battery prorated for five years.
- Meets UL924, NFPA 101 Life Safety Code, NEC, OSHA, Local and State Codes.
- UL Listed for damp locations (0°C – 50°C).
- Certified to CEC under Title 20 Regulations.

DIMENSIONS

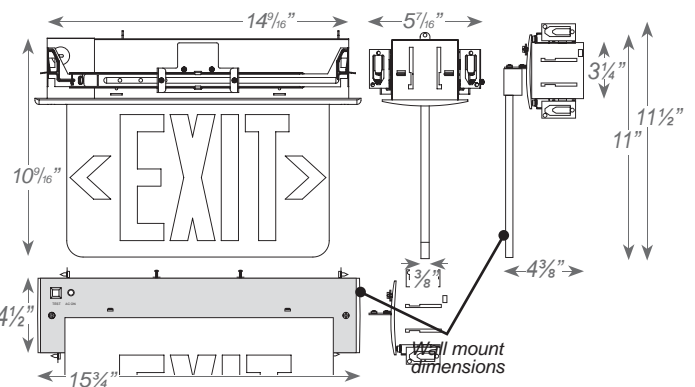

ORDERING INFORMATION

Sample Part Number: X91RCWEM

MODEL	No. of FACES	LETTER	PANEL	TRIM PLATE	BATTERY	OPTIONS
X9	1	Single Face	Red	C	Clear ¹	W White
	2	Double Face	Green	W	Mirror	Black
				A	White	Aluminum
					(blank)	
					EM	Batte Backup
						WM Wall Mount ¹
						2C-120 Dual Circuit With 120V Input ²
						2C-277 Dual Circuit With 277V Input ²
						SDT Self-Diagnostics ³
						USA Assembled In USA
						SPV 208/220/240 Volt, 50/60Hz ⁴
						CUSTOM Custom Wording

¹ With single face only.

² Available only with AC units.

³ Available only with EM units.

⁴ Not available with SDT.