

LHB

LED Full Body High Bay



STANDARD

OPTIONAL



DESCRIPTION

The LHB is an LED full body high bay that is a quality and economical solution for commercial lighting needs. Perfect for applications such as garages, warehouses, gyms, manufacturing space, and large retail spaces. With an enclosed power supply and covered optics, these light fixtures are designed for durability in commercial or industrial applications. They are designed to save energy and lower maintenance costs. The LED light engine inside this fixture uses 30% less power to produce the same amount of light as a fluorescent fixture. This is a low maintenance solution that eliminates the need to replace power supplies and light bulbs because the light source is integrated in the fixture.

CONSTRUCTION

The LHB is constructed out of heavy gauge steel.

OPTICAL SYSTEM

Choice of no lens, clear lens (option CLL), or diffusing lens (DIL). Professional light distribution technique used for light transmission rate of lens is over 90%.

ELECTRICAL SYSTEM

Electronic drivers are standard for 120/277V Applications. Step-Down transformers are required for 347-480V Applications. Long-life LED system rated for >120K life hours (L70 @ 25°C). Metal gear tray for internal LED driver. Complies with federal energy efficiency standards.

LISTINGS

Fixtures are UL listed and IC rated for contact with insulation and can be installed in damp locations. They are DLC listed to qualify for commercial lighting rebates and special incentives in certain areas.

FINISH

High gloss, electrostatically applied, white powder coat finish, average minimum reflectance 92%

LED

80 CRI or 90 CRI LEDs available in 3000K, 3500K, 4000K and 5000K. Life is 100,000 hours at 70% lumen maintenance.

WARRANTY

5 - Year Limited Warranty. Complete warranty and terms located at: www.aelnow.com/warranty

ORDERING INFORMATION

Example: LHB21H-40-M

SERIES		CCT		VOLTAGE		OPTIONS	
LHB2	1x2, 87W	40	4000K	M	120-277V	12EBL	1200 Lumen Emergency Ballast
LHB2M	1x2, 132W	50	5000K	480	347-480V	LHBWG	Steel White Wire Guard
LHB2H	1x2, 180W					LHBPM	Pendant Mount Kit
LHB21H	1.5x2, 215W					PHBSM	Surface Mount Kit
LHB4L	1x4, 265W					POS	Passive Infrared Occ Sensor
LHB4M	1x4, 320W					MDS	Microwave Occ Sensor
LHB41H	1.5x4, 425W					AC10	100" Aircraft Adjustable Cable
						CLL	Clear Lens
						DIL	Diffusing Lens
						WG	Wire Guard

FIXTURE DIMENSIONS

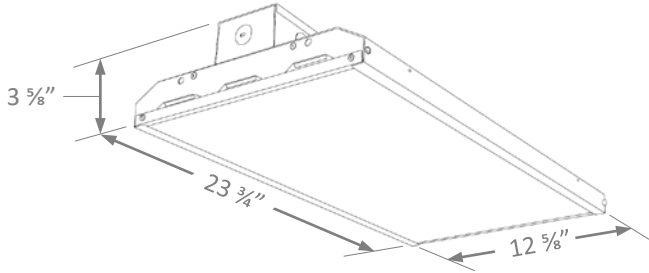

LHB2, LHB2M, LHB2H

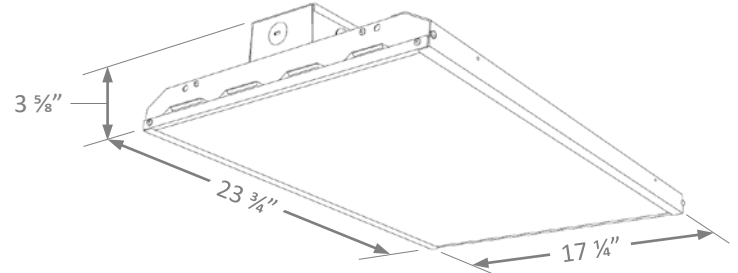

LHB21H

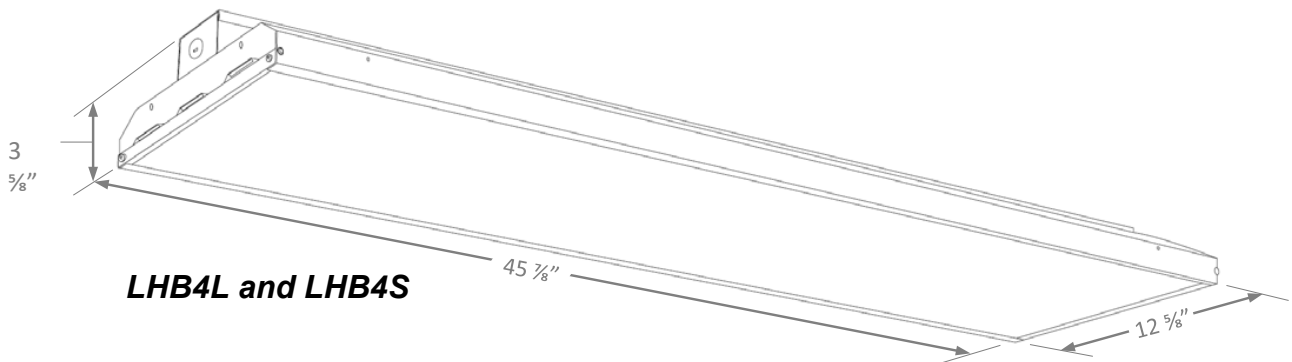

LHB4L and LHB4S

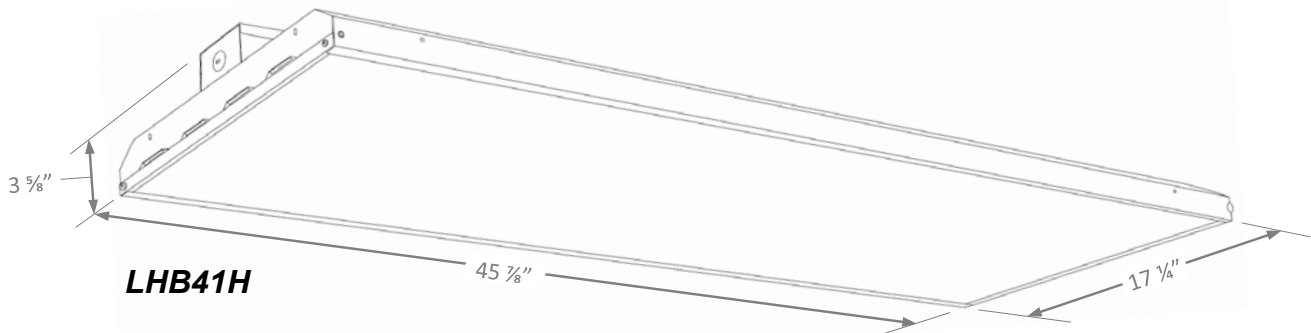

LHB41H

LED SYSTEM DATA			
SERIES	SIZE	WATTAGE	LUMENS
LHB2	1x2	87W	12394lm
LHB2M	1x2	132W	18564lm
LHB2H	1x2	180W	25298lm
LHB21H	1.5x2	213W	30356lm
LHB4L	1x4	267W	37996lm
LHB4M	1x4	320W	44460lm
LHB41H	1.5x4	428W	60629lm

ENERGY AND PERFORMANCE DATA

Input Voltage	120/277VAC
System Input Power	87 - 428 Watts
Delivered Lumen Output	12394 - 60629 Lumens
Standard Dimming Control	0-10V
CCT	3000, 3500, 4000, 5000 Kelvin
CRI	82 (minimum)
Life Time Rating	>120,000 hrs @ L70
Input Frequency	50/60 Hz
Power Factor	>0.9
Operating Temp	-20° to 50° C

*Actual wattage may differ by ±5% while operating 120/277V ±10%