

EM22-16BAA

BAA Compliant MR-16 Emergency Unit



STANDARD



OPTIONAL



ILLUMINATION

- Two fully adjustable, semi-recessed ultra bright, 7.0 watt, MR-16 halogen lamp heads standard.
- High performance MR16 halogen lamps with smooth metallized reflector and glass lens for optimal light distribution.

ELECTRICAL

- Dual 120/277 voltage.
- Charge rate/power "ON" LED indicator light and push-to-test switch for mandated code compliance testing.
- LVD (low voltage disconnect) prevents battery from deep discharge.
- 6V maintenance-free, rechargeable sealed lead acid battery.
- Internal solid-state transfer switch automatically connects the internal battery to lamp heads for minimum 90-minute emergency illumination.
- Fully automatic solid-state, two rate charger initiates battery charging to recharge a discharged battery in 24 hours.

MOUNTING

Universal knockout pattern on back plate for wall mount. Snaps into place making internal electrical connections.

- Knockout for conduit applications.

HOUSING

- Injection-molded, engineering grade, 5VA flame retardant, high-impact resistant, thermoplastic in white or black finish.

OPTIONS

- LED: 3.3W high performance MR-16 base LED lamps for increased center-to-center spacing.
- PLED: 5.0W high performance MR-16 base LED lamps for premium center-to-center spacing

WARRANTY / LISTING

- Five year warranty on all electronics and housing. Battery prorated for two years.
- Meets UL924, NFPA 101 Life Safety Code, NEC, OSHA, Local and State Codes.
- UL Listed for damp locations (20°C – 40°C).

DIMENSIONS

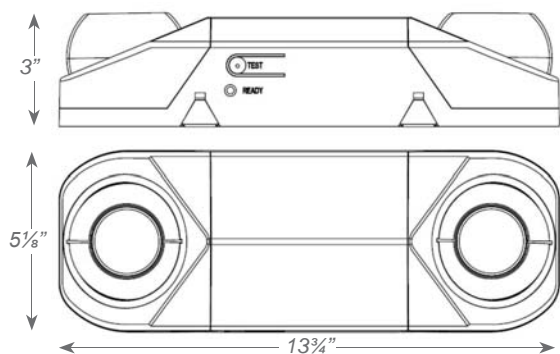

ORDERING INFORMATION

Sample Part Number: **EM22-16BAA**

Special voltage options available.
Check with your local Representative.

MODEL	HOUSING COLOR		OPTIONS	
EM22-16BAA	(blank)	White	LED	3.3W High Lumen White LED Lamps
	B	Black	PLED	5.0W High Lumen White LED Lamps