

EM11R-16BAA

BAA Compliant MR-16 Emergency Unit



STANDARD



OPTIONAL

ILLUMINATION

- Two fully adjustable, 5.0 watt, MR-16 halogen lamp heads standard.
- High performance MR16 halogen lamps with smooth metallized reflector and glass lens for optimal light distribution.

ELECTRICAL

- Dual 120/277 voltage.
- Charge rate/power "ON" LED indicator light and push-to-test switch for mandated code compliance testing.
- LVD (low voltage disconnect) prevents battery from deep discharge.
- 6V maintenance-free, rechargeable sealed lead acid battery.
- Internal solid-state transfer switch automatically connects the internal battery to lamp heads for minimum 90-minute emergency illumination.
- Fully automatic solid-state, two rate charger initiates battery charging to recharge a discharged battery in 24 hours.

MOUNTING

- Universal knockout pattern on back plate for wall mount. Snaps into place making internal electrical connections.
- Knockout for conduit applications.

HOUSING

- Injection-molded, engineering grade, 5VA flame retardant, high-impact resistant, thermoplastic in white finish.

OPTIONS

- SDT: Self-diagnostic feature performs monthly, biannual, and annual tests to ensure reliable operation and meet electrical and life safety codes.
- HTR: Optional internal heater for cold temperature (-9°C – 50°C) applications.
- LED: 3.3W high performance MR-16 base LED lamps for increased center-to-center spacing.
- PLED: 5.0W high performance MR-16 base LED lamps for premium center-to-center spacing.

WARRANTY / LISTING

- Five year warranty on all electronics and housing. Battery pro rated for two years.
- Meets UL924, NFPA 101 Life Safety Code, NEC, OSHA, Local and State Codes.
- UL Listed for damp locations (20°C – 40°C).

DIMENSIONS

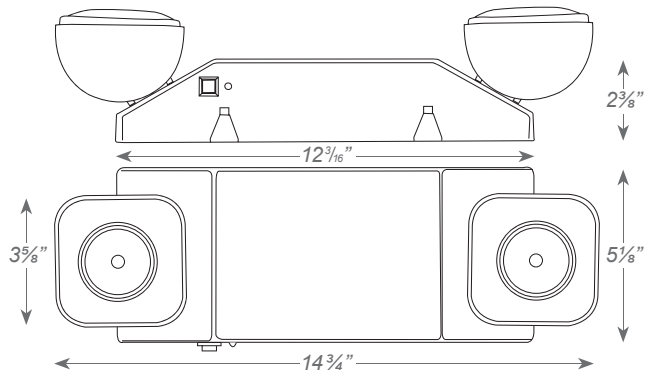

ORDERING INFORMATION

Special voltage options available.
Check with your AEL Representative.
Note:

1. Not available for LED option

MODEL	HOUSING COLOR		OPTIONS	
	Blank	White	Code	Description
EM11R-16BAA			SDT ¹	Self-Diagnostics
			HTR	Internal Heater
			LED	3.3W High Lumen White LED Lamp
			PLED	5.0W High Lumen White LED

Sample Part Number: EM11R-16BAA