

SPJ26-03

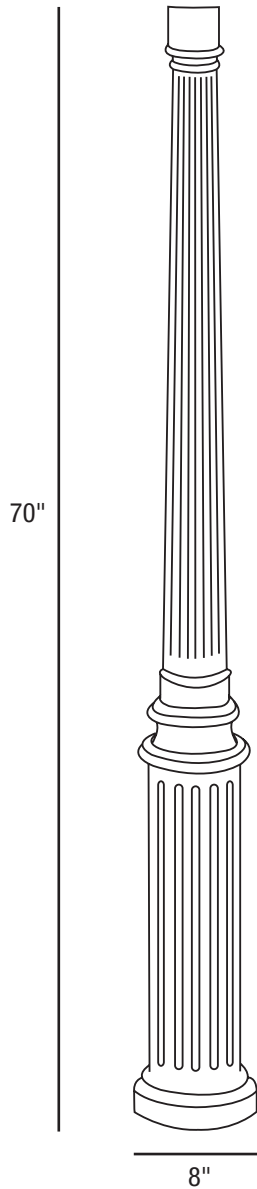

Anchor Bolt Pattern

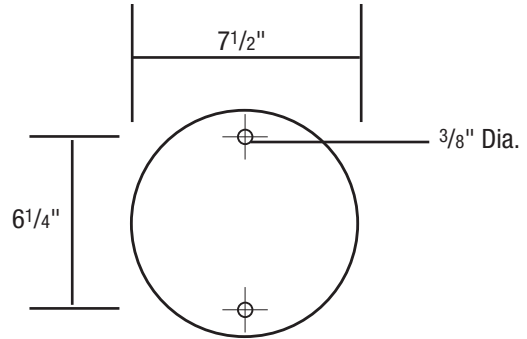

MODEL: SPJ26-03
MOUNTING : (2) Stainless Bolts & Anchors
Finishes:
 PCB = Black
 PBR = Bronze
 PR = Rusty
 PW = White
 PC = Powder Coat Custom

SCALE:	DRAWN BY: MMC	BASE DESIGN: SPJ	DATE: 8-07-02
--------	---------------	------------------	---------------

SPJ LIGHTING INC.
 2107 Chico Avenue
 South El Monte, CA 91733
 (800) 469-3637 FAX: (626) 433-4839

