

MB1000

Mailbox

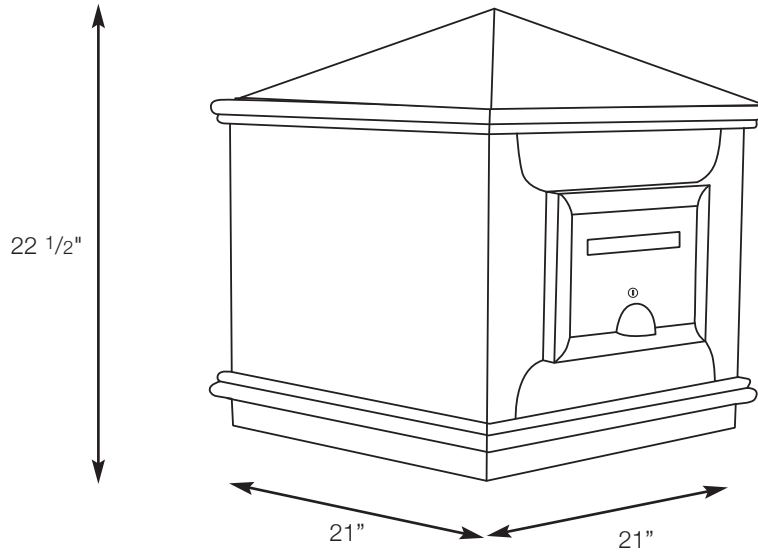

MODEL: MB1000
MATERIAL : Solid Brass or Copper
FINISH : Specify
MOUNTING : Pilaster Mailbox



DRAWN BY: MMC

BASE DESIGN: SPJ

DATE: 01-10-10

SPJ LIGHTING INC.

2107 Chico Avenue
South El Monte, CA 91733
(800) 469-3637 FAX: (626) 433-4839