



# **Sure-Lites INVW-S & INVW-T Series Installation & User's Guide**

**NEMA 3R OUTDOOR  
EMERGENCY LIGHTING CENTRAL INVERTER**

**3kW – 8kW SINGLE PHASE**

**4kW – 10kW THREE PHASE**

This unit contains LETHAL VOLTAGES. All repairs and service should be performed by AUTHORIZED SERVICE PERSONNEL ONLY! There are NO USER SERVICEABLE PARTS inside this unit.

## IMPORTANT SAFEGUARDS

When using electrical equipment, you should always follow basic safety precautions, including the following:

- 1. READ AND FOLLOW ALL SAFETY INSTRUCTIONS.**
- 2. Do not install near gas or electric heaters or in other high-temperature locations.**
- 3. Use caution when servicing batteries. Depending on battery type, batteries contain either acid or alkali and can cause burns to skin and eyes. If battery fluid is spilled on skin or in the eyes, flush with fresh water and contact a physician immediately.**
- 4. Equipment should be mounted in locations where unauthorized personnel will not readily subject it to tampering.**
- 5. The use of accessory equipment not recommended by Manufacturer may cause an unsafe condition and void the warranty.**
- 6. Do not use this equipment for other than its intended use.**
- 7. Qualified service personnel must perform all servicing of this equipment.**

## SAVE THESE INSTRUCTIONS

The installation and use of this product must comply with all national, federal, state, municipal, or local codes that apply. If you need help, please call Service.

**CAUTION**

**READ ENTIRE MANUAL AND REVIEW ALL DOCUMENTATION BEFORE ATTEMPTING SYSTEM  
INSTALLATION!**

**FOR YOUR PROTECTION....  
PLEASE COMPLETE AND RETURN WARRANTY REGISTRATION CARD IMMEDIATELY.**

# TABLE OF CONTENTS

## SECTION 1

page(s)

|                                      |          |
|--------------------------------------|----------|
| <b>Safety Warning</b> .....          | <b>5</b> |
| <b>Battery Storage Warning</b> ..... | <b>6</b> |

## SECTION 2

|                           |            |
|---------------------------|------------|
| <b>Introduction</b> ..... | <b>7-9</b> |
|---------------------------|------------|

## SECTION 3

|   |              |
|---|--------------|
| <b>Before installing the system</b> ..... | <b>10-13</b> |
| Installation Dimensions and clearances    |              |
| Location Guidelines                       |              |
| Storage and operating Environment         |              |
| Installation overview                     |              |

## SECTION 4

|  |              |
|--|--------------|
| <b>AC input &amp; AC output Installation</b> ..... | <b>14-17</b> |
|--|--------------|

## SECTION 5

|   |              |
|---|--------------|
| <b>Installing batteries and DC wiring</b> ..... | <b>18-29</b> |
| Safety instructions                             |              |
| Before installing the batteries                 |              |
| Installing and connecting the batteries         |              |
| Replacing the batteries                         |              |
| Battery interconnect diagrams                   |              |

## SECTION 6

|   |              |
|---|--------------|
| <b>Startup and shutdown procedure</b> ..... | <b>30-32</b> |
| Maintenance bypass for non-break systems    |              |

## SECTION 7

|                        |           |
|------------------------|-----------|
| <b>Operation</b> ..... | <b>33</b> |
|------------------------|-----------|

## SECTION 8

|                                  |              |
|----------------------------------|--------------|
| <b>Front panel display</b> ..... | <b>34-38</b> |
| Control panel keypads            |              |
| Meter functions                  |              |
| Control functions                |              |
| Program functions                |              |
| Automatic tests                  |              |

## SECTION 9

|                            |              |
|----------------------------|--------------|
| <b>Options.....</b>        | <b>39-43</b> |
| Output circuit breaker(s)  |              |
| Summary dry contact        |              |
| Remote summary alarm panel |              |
| Remote panel meter         |              |

## SECTION 10

|                             |              |
|-----------------------------|--------------|
| <b>RS232 operation.....</b> | <b>44-57</b> |
| Introduction                |              |
| Connection                  |              |
| Protocol                    |              |
| Commands                    |              |
| Control functions           |              |
| Hyper terminal setup        |              |
| Configuring ZOOM modem      |              |
| Dialing ZOOM modem          |              |

## SECTION 11

|                            |           |
|----------------------------|-----------|
| <b>Specifications.....</b> | <b>58</b> |
|----------------------------|-----------|

## SECTION 12

|                                     |              |
|-------------------------------------|--------------|
| <b>Maintenance and service.....</b> | <b>59-60</b> |
| Trouble shooting chart              |              |

## SECTION 13

|  |              |
|--|--------------|
| <b>Heater Option Installation and Operation.....</b> | <b>61-62</b> |
|--|--------------|

## SECTION 14

|                                   |           |
|-----------------------------------|-----------|
| <b>Anchor Bolt Placement.....</b> | <b>63</b> |
|-----------------------------------|-----------|

## SECTION 15

|                      |              |
|----------------------|--------------|
| <b>Warranty.....</b> | <b>64-65</b> |
|----------------------|--------------|

## SECTION 16

|                                    |           |
|------------------------------------|-----------|
| <b>Cabinet Detail Drawing.....</b> | <b>66</b> |
|------------------------------------|-----------|

## SECTION 1

# SAFETY WARNINGS

Read the following precautions before you install this emergency lighting system.

### IMPORTANT SAFETY INSTRUCTIONS

SAVE THESE INSTRUCTIONS. This manual contains important instructions that you should follow during installation and maintenance of the system and batteries. Please read all instructions before operating the equipment and save this manual for future reference.

---

### DANGER

This system contains **LETHAL VOLTAGES**. **AUTHORIZED SERVICE PERSONNEL** should perform all repairs and service **ONLY**. There is **NO USER SERVICEABLE PARTS** inside the UPS.

---

### WARNING

- Do not install near gas or electric heaters or in other high-temperature locations.
  - Use caution when servicing batteries. Battery acid can cause burns to skin and eyes. If acid is spilled on skin or in the eyes, flush with fresh water and contact a physician immediately.
  - Equipment should be mounted in locations where it is not readily subjected to tampering by unauthorized personnel.
  - The use of accessory equipment not recommended by the manufacturer may cause an unsafe condition.
  - Do not use this equipment for other than intended use.
  - Only qualified service personnel (such as a licensed electrician) should perform the system and battery installation and initial startup. Risk of electrical shock.
-

# BATTERY STORAGE WARNING

This shipment contains rechargeable, maintenance free batteries. They must be stored properly to assure proper operation upon installation. Therefore, please follow the following guidelines when storing batteries:

- 1) Store in clean, dry and cool location. While it is safe to store batteries in environments of -18 to 40 degrees C (0 to 104 degrees F), it is recommended that you do not store at temperatures above 30 degrees C (86 degrees F). The warmer the ambient temperature, the higher the self discharge rate of the battery. This will require more frequent recharge of the individual batteries until they are placed in service.
- 2) Avoid storing in direct sunlight or in front of or near heaters, heat duct or other sources of heat.
- 3) Do not store directly on concrete structures. Always store on wooden pallets or metal shelves near floor level.
- 4) Place the batteries in service within 180 days of receipt. If you cannot place the batteries in service within the 180 days, then the batteries must be recharged every 180 days, (more frequently if stored at elevated temperatures) while in storage. Failure to do so will void the warranty and may cause irreversible damage to the battery.

## SECTION 2

# INTRODUCTION

**Keep this Guide in the folder mounted inside the unit.**

This unit is a microprocessor controlled PWM (Pulse Width Modulated) pure sine wave based DC to AC power inverter utilizing IGBT technology. It integrates a fully automatic 3-rate battery charger, a solid-state transfer system, control circuitry, self testing and recording digital meter display, and maintenance free sealed lead calcium type batteries. The system components are carefully matched to make the unit a completely self-contained, fully automatic standby power source for operation on all types of lighting loads. The batteries are sized and tested per UL-924 and Life Safety Code ANSI / NFPA 101, providing emergency power for a minimum of 90 minutes.

If the duration of a power failure is greater than the batteries storage capability, the inverter will automatically shut down when the battery voltage reaches 85% of the nominal DC voltage. This feature protects the battery from being permanently damaged from a deep discharge that could cause cell reversal. This battery protection feature is called "Low Voltage Disconnect" or L.V.D.

When the AC power is restored after a full discharge, the system will be ready for another power failure within 24hrs. If another power failure occurs before the 24-hour recharge time, the run time will be decreased.

The front panel display incorporates an alphanumeric 2x20 LCD character display, LED status indicators and a 4 x 4 keypad. All user interface functions are available from the front panel assembly.

Utilizing a small footprint, this unit is for use with any lighting load including quartz, HID, incandescent, and fluorescent and halogen.

### HOW TO USE THIS MANUAL

This manual tells you how to install, start, operate, and communicate with your unit and lets you know how to get more information for special situations.

Please record your unit's part number, serial number, and model number below. You can find these numbers on the labels on the inside panel.

Part Number \_\_\_\_\_

Serial Number \_\_\_\_\_

Model Number \_\_\_\_\_



## **Record Keeping**

An on-site permanent log of the inspection, testing, and maintenance of the emergency electrical power supply system shall be maintained in accordance with this manual.

The log shall include:

The date on which the inspection, testing, and maintenance exercise was carried out.

The name of the person(s) who performed the inspection, testing, and maintenance.

A note of any unsatisfactory condition observed or discovered, and the steps taken to correct the condition.

## Service and Support

We are committed to outstanding customer service. A service technician is available **24** hours a day, **365** days a year. Service is also available **24** hours a day to give you access to technical notes and product information.

**NOTE:** Please have your unit's Serial and Part numbers available when you call; this number is located behind the right door.

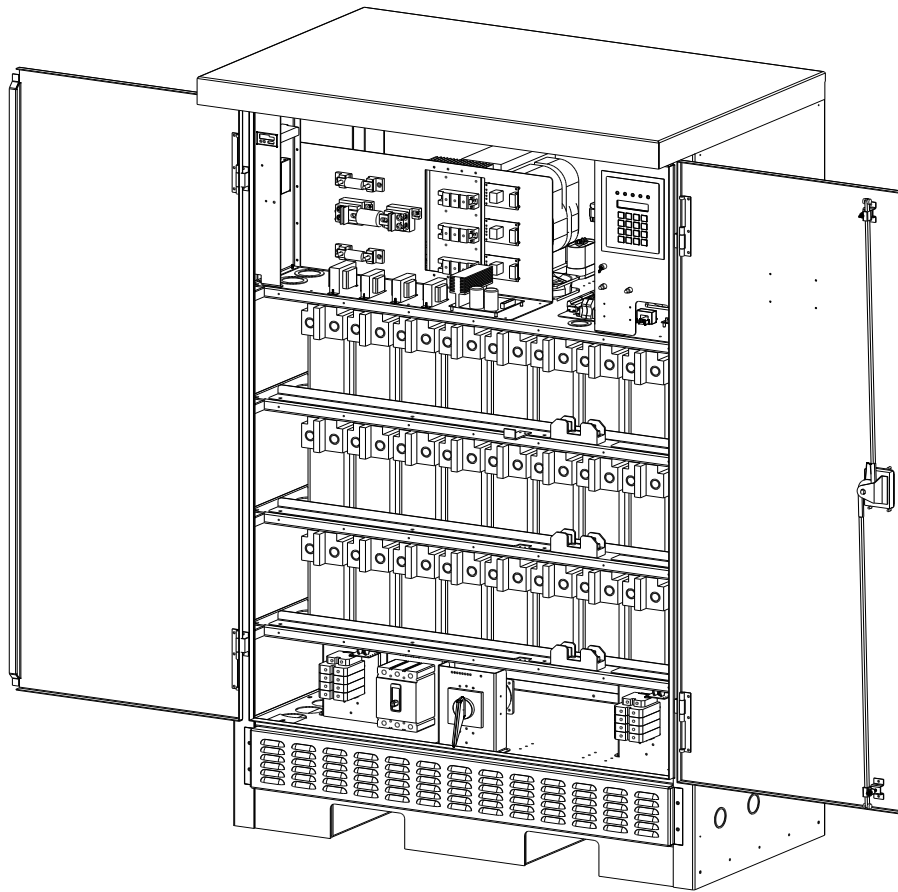

## SECTION 3

# BEFORE INSTALLING THE SYSTEM

## Installation Dimensions and Clearances

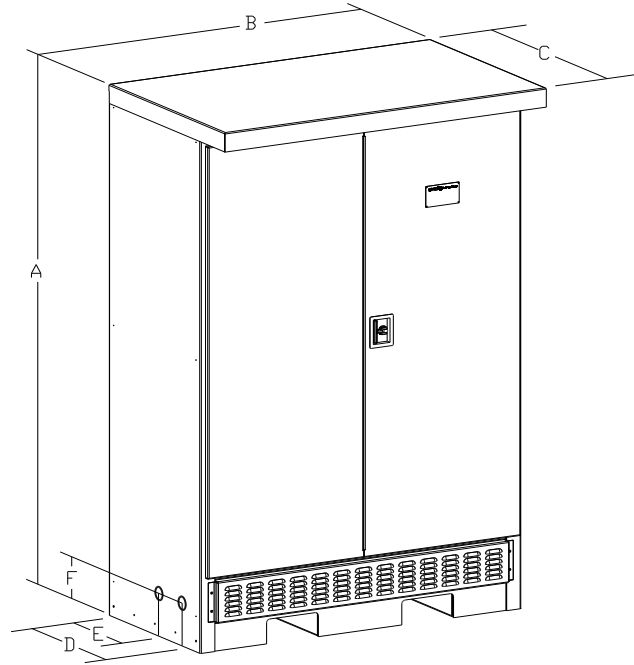

Figure 3.1 System Dimensions

Table 3.1 Dimensions

| Unit            | Height<br>(A)   | Width<br>(B)    | Depth<br>(C)     | (D)              | (E)            | (F)                  |
|-----------------|-----------------|-----------------|------------------|------------------|----------------|----------------------|
| Unit<br>Cabinet | 76"<br>(193 cm) | 48"<br>(122 cm) | 30"<br>(76.2 cm) | 19"<br>(48.3 cm) | 13"<br>(33 cm) | 6 1/8"<br>(15.56 cm) |

Table 3.2 Required Clearances

| Sides          | Top            | Front           |
|----------------|----------------|-----------------|
| 0"<br>(0.0 cm) | 0"<br>(0.0 cm) | 48"<br>(122 cm) |

Table 3.3 Conduit Knockouts

| All |                   |  |
|-----|-------------------|--|
|     | 3/4"<br>(1.91 cm) |  |

## Location Guidelines:

### CAUTION

- Choose a permanent location for the unit. Attempting to move them after you have installed the batteries can damage the batteries and the cabinet.

This equipment is heavy. Refer to Table 3.4 when you choose a site to make sure that the floor can support the weight of the system, the batteries, and any other necessary equipment.

**Table 3.4 System weight [in lbs. (kg)]**

| <u>System Models for 90 Minute run time</u> |                     |               |               |                |                |                    |               |                |                |                |
|---|---------------------|---------------|---------------|----------------|----------------|--------------------|---------------|----------------|----------------|----------------|
|   | <u>Single Phase</u> |               |               |                |                | <u>Three Phase</u> |               |                |                |                |
|   | 3.0kw               | 4.0kw         | 5.0kw         | 6.5kw          | 8.0kw          | 4.0kw              | 5.0kw         | 6.5kw          | 8.0kw          | 10.0kw         |
| Unit with Standard SLC Batteries            | 1545<br>(700)       | 1693<br>(768) | 1915<br>(865) | 2285<br>(1037) | 2581<br>(1171) | 1883<br>(854)      | 2105<br>(955) | 2475<br>(1123) | 2875<br>(1305) | 2875<br>(1305) |
| Unit without Batteries                      | 805<br>(365)        | 805<br>(365)  | 805<br>(365)  | 805<br>(365)   | 805<br>(365)   | 995<br>(451)       | 995<br>(451)  | 995<br>(451)   | 1099<br>(499)  | 1099<br>(499)  |

## Receiving and Moving the Unit and the Batteries

Systems weigh several hundred pounds; (see Table 3.4; ask your sales representative for additional information). Make sure you are prepared for these weights before you unload or move the unit or the batteries. Do not install any batteries until you have permanently installed the unit and any battery cabinets and connected all conduit and wiring.

## Storage and Operating Environment

Make sure you store the system in a clean, cool, dry place with normal ventilation and level floors.

### Storage Temperature

Store the batteries (in the system) at -18 to 40°C (0 to 104°F). Batteries have a longer shelf life if they are stored below 25°C (77°F). Keep stored batteries fully charged. Recharge the batteries every 90–180 days. The system without batteries may be stored at -20 to 70°C (-4 to 158°F).

### Ventilation

The air around the unit must be clean, dust-free, and free of corrosive chemicals or other contaminants. Do not place the system or batteries in a sealed room or container.

### Operating Temperature

System can operate from -20 to 40° (-4 to 104°F) and up to 95% relative humidity. The batteries' service life is longer if the operating temperature stays below 25°C (77°F).

### Batteries

The temperature should be near 25°C (77°F) for optimum battery performance. Batteries are less efficient at temperatures below 18°C (65°F), and high temperatures reduce battery life. Typically, at about 35°C (95°F), battery life is half of what it would be at a normal temperature of 25°C (77°F). At about 45°C (113°F), battery life is one-fourth of normal.

Make sure that heaters, sunlight, air conditioners, or outside air vents are not directed toward the batteries. These conditions can make the temperature within battery strings vary, which can cause differences in the batteries' voltages. Eventually, these conditions affect battery performance.

If the batteries are not in the system, remember that the batteries should be installed as close as possible to the unit to reduce DC wiring costs and improve battery performance.

Do not allow tobacco smoking, sparks, or flames in the system location because hydrogen is concentrated under the vent cap of each cell of the battery. Hydrogen is highly explosive, and it is hard to detect because it is colorless, odorless, and lighter than air.

Every type of battery can produce hydrogen gas, even sealed maintenance-free batteries. The gas is vented through the vent caps and into the air, mainly when the unit is charging the batteries. The batteries produce the most hydrogen when maximum voltage is present in fully charged batteries. The amount of current that the charger supplies to the batteries (not the battery ampere-hour) determines how much hydrogen is produced.

### High Altitude Operation

The maximum operating ambient temperature drops 1°C per 300m (2°F per 1000 ft) above sea level. Maximum elevation is 3000m (10,000 ft).

# INSTALLATION OVERVIEW

Figure 3.2 shows typical installations of system.

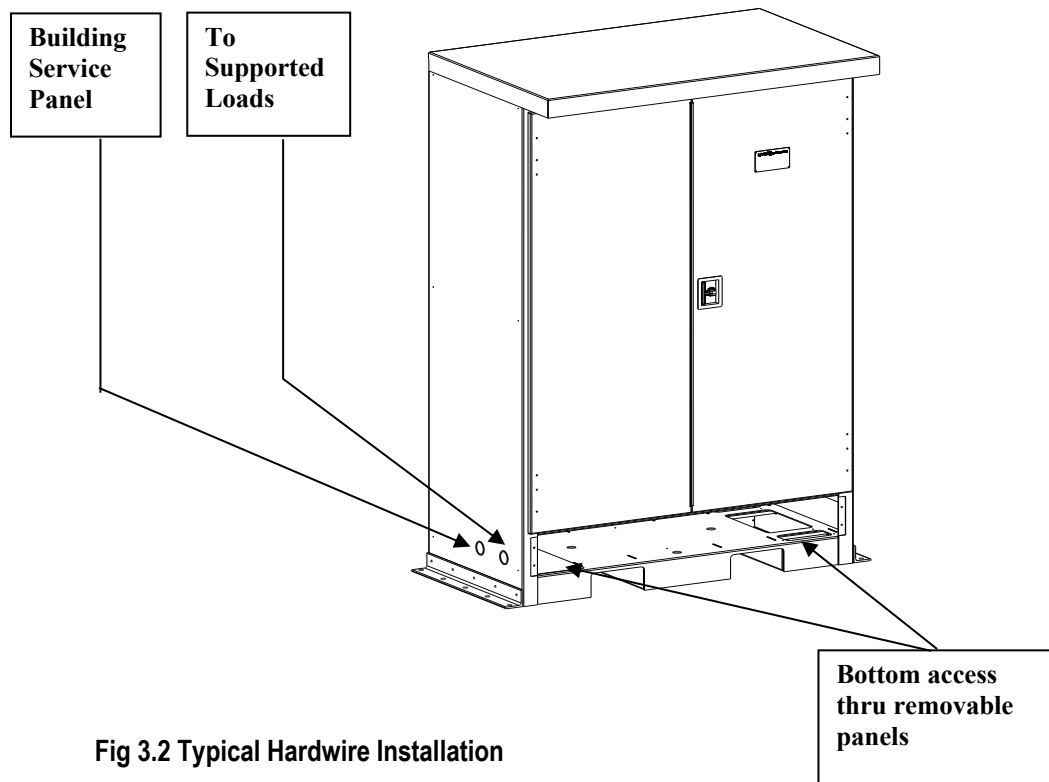

**(See Section 14 for Anchor Bolt Placement)**

## SECTION 4

# AC INPUT & AC OUTPUT INSTALLATION

### WARNING

Only qualified service personnel (such as a licensed electrician) should perform the AC installation. Risk of electrical shock.

---

Read the following cautions before you continue.

### CAUTION

- Unit contains hazardous AC and DC voltages. Because of these voltages, a qualified electrician must install the system, AC line service, and batteries. The electrician must install the AC line service according to local and national codes and must be familiar with batteries and battery installation.
  - Before you install, maintain, or service the unit, always remove or shut off all sources of AC and DC power and shut off the system. You must disconnect AC line input at the service panel and turn off the Installation Switch (S1), the Main AC Input Circuit Breaker (CB1), and the Battery Fuse(s) to make sure the unit does not supply output voltage.
  - Whenever AC and/or DC voltage is applied, there is AC voltage inside the unit; this is because the unit can supply power from AC line or from its batteries. To avoid equipment damage or personal injury, always assume that there may be voltage inside the unit.
  - Remove rings, watches, and other jewelry before installing the AC wiring. Always wear protective clothing and eye protection and use insulated tools when working near batteries. Whenever you are servicing an energized unit with the inside panel open, electric shock is possible; follow all local safety codes. **TEST BEFORE TOUCHING!**
- 

1. Open the unit's doors. Make sure the installation switch and the input circuit breaker are off, and the battery fuse removed inside the unit.
2. Look at the ID label on the inside right door. Write down the following information:  
Input Voltage: \_\_\_\_\_  
Output Voltage: \_\_\_\_\_
3. Now, make sure the input and output voltages are what you need.
  - Does the input voltage available for the system at the AC service panel match the input voltage shown on the unit's ID label?  
Service Panel Voltage = \_\_\_\_\_ Input Voltage \_\_\_ Yes / \_\_\_ No
  - Does the output voltage on the ID label match the voltage your loads (protected equipment) need?  
Load Voltage = \_\_\_\_\_ Output Voltage \_\_\_ Yes / \_\_\_ NoIf you answered NO to either of the preceding questions, **call SERVICE.**

4. Now, use the information you wrote down in Step 2 to find the correct circuit breaker for the service panel that is for your system.

**Table 4.1 Recommended Circuit Breaker for Maximum Input Current**

| System  | Input Voltage (Vac) | Max. Current | Recommended Circuit Breaker |
|---------|---------------------|--------------|-----------------------------|
| 3.0kW   | 120V                | 32 amps      | 40A, 1-Pole                 |
| 3.0kW   | **208V              | 18 amps      | 25A, 2-Pole                 |
| 3.0kW   | **240V              | 16 amps      | 20A, 2-Pole                 |
| 3.0kW   | 277V                | 14 amps      | 20A, 1-Pole                 |
| 3.0kW   | **480V              | 8 amps       | 10A, 2-Pole                 |
| 4.0kW   | 120V                | 42 amps      | 50A, 1-Pole                 |
| 4.0kW   | **208V              | 24 amps      | 30A, 2-Pole                 |
| 4.0kW   | **240V              | 21 amps      | 30A, 2-Pole                 |
| 4.0kW   | 277V                | 18 amps      | 25A, 1-Pole                 |
| 4.0kW   | **480V              | 11 amps      | 15A, 2-Pole                 |
| 4.0kW   | 120/208V            | 14 amps      | 20A, 3-Pole                 |
| 4.0kW   | 277/480V            | 6 amps       | 10A, 3-Pole                 |
| 5.0kW   | 120V                | 52 amps      | 70A, 1-Pole                 |
| 5.0kW   | **208V              | 30 amps      | 40A, 2-Pole                 |
| 5.0kW   | **240V              | 26 amps      | 35A, 2-Pole                 |
| 5.0kW   | 277V                | 23 amps      | 30A, 1-Pole                 |
| 5.0kW   | **480V              | 13 amps      | 20A, 2-Pole                 |
| 5.0kW   | 120/208V            | 17 amps      | 25A, 3-Pole                 |
| 5.0kW   | 277/480V            | 8 amps       | 10A, 3-Pole                 |
| 6.5kW   | 120V                | 68 amps      | 90A, 1-pole                 |
| 6.5kW   | **208V              | 39 amps      | 50A, 2-Pole                 |
| 6.5kW   | **240V              | 34 amps      | 45A, 2-Pole                 |
| 6.5kW   | 277V                | 29 amps      | 40A, 1-Pole                 |
| 6.5kW   | **480V              | 17 amps      | 25A, 2-Pole                 |
| 6.5kW   | 120/208V            | 23 amps      | 30A, 3-Pole                 |
| 6.5kW   | 277/480V            | 10 amps      | 15A, 3-Pole                 |
| 8.0 kW  | 120V                | 84 amps      | 100A, 1-Pole                |
| 8.0 kW  | **208V              | 48 amps      | 60A, 2-Pole                 |
| 8.0 kW  | **240V              | 42 amps      | 50A, 2-Pole                 |
| 8.0 kW  | 277V                | 36 amps      | 45A, 1-Pole                 |
| 8.0 kW  | **480V              | 21 amps      | 30A, 2-Pole                 |
| 8.0 kW  | 120/208V            | 28 amps      | 35A, 3-pole                 |
| 8.0 kW  | 277/480V            | 12 amps      | 15A, 3-pole                 |
| 10.0 kW | 120/208V            | 37 amps      | 45A, 3-pole                 |
| 10.0 kW | 277/480V            | 16 amps      | 20A, 3-pole                 |

**\*\* WARNING: THE EXTERNAL INPUT CIRCUIT BREAKER PROTECTING THE SYSTEM MUST BE A “MOTOR START”, DELAYED TRIP TYPE. THIS IS DUE TO MAGNETIC INRUSH CURRENT DRAWN DURING APPLICATION OF AC POWER. PLEASE NOTE THAT THIS APPLIES TO ANY UNIT THAT HAS A DIFFERENCE BETWEEN THE INPUT AND THE OUTPUT VOLTAGES.**

5. Write down the circuit breaker value that applies to your system from Table 4.1:

\_\_\_\_\_



- Now, refer to Table 4.2 and use the notes to find the proper gauge wire for the recommended circuit breaker recorded in step 5.

**Table 4.2 Recommended Minimum Wire Sizes**

| Read These Important Notes!  | For this Input Circuit Breaker Size... | Use this Size 90°C Copper Wire |                 |
|--|--|--------------------------------|-----------------|
|  |  | AWG                            | mm <sup>2</sup> |
| This table lists the AWG and mm <sup>2</sup> wire size for each circuit breaker size. The minimum recommended circuit breaker sizes for each model and voltage application are listed in Table 4.1. The temperature rating of conductor must not be less than 90° C wire. Based on the ampacities given in Tables 310-16 of the National Electrical Code, ANSI/NFPA 70-1993 (Table 2 of the CEC), and NEC article 220 (CEC Section 4). Circuit conductors, must be the same size (ampacity) wires and equipment-grounding conductors must meet Table 250-95 of the National Electrical Code. Code may require a larger wire size than shown in this table because of temperature, number of conductors in the conduit, or long service runs. Follow local code requirements. | 10, 15, 20                             | 12                             | 3.31            |
|  | 25, 30                                 | 10                             | 5.26            |
|  | 35, 40, 45                             | 8                              | 8.36            |
|  | 50, 60                                 | 6                              | 13.30           |
|  | 70, 80                                 | 4                              | 21.15           |
|  | 90, 100                                | 2                              | 33.62           |

- The input circuit breaker in the input service panel provides the means for disconnecting AC to the unit. Only authorized persons shall be able to disconnect AC to the unit [see NEC 700-20 and 700-21(CEC Section 46)]. If you are using the input circuit breaker to disconnect AC, you must make sure that only authorized persons have control of the circuit breaker panel to meet the requirements of NEC 700-20 (CEC Section 46).

- Read the following caution, before removing conduit knockouts.

**CAUTION**

To prevent electrical shock or damage to your equipment, the Installation Switch (S1), the Main AC Input Circuit Breaker (CB1), and the circuit breaker at the input service panel should all be turned off. The Main DC Battery Fuse and the external DC Disconnect Fuse(s) (if you have one) should be removed.

- Remove knockouts for AC Input and AC Output in the right or left side of the system. AC input conductors and AC output conductors must be installed in separate conduits, and emergency and non-emergency output circuits must be installed in separate conduits.

**CAUTION**

Do not drill the cabinet; drill filings may damage the unit and keep it from operating. If you need larger knockouts, use a chassis punch to punch out the appropriate knockout. Do not create additional knockouts.

- Install the conduit. You must run the AC input service conductors and AC output conductors through separate conduits. Emergency output conductors and non-emergency output conductors must also be run through separate conduits. Emergency output circuits shall be installed in dedicated conduit systems and not shared with other electrical circuits as described in NEC 700-9(b) [CEC Section 47-108].

The next step explains where to make the AC connections to the system.

## INSTALLING AC INPUT WIRES:

11. Connect AC utility from the service panel to the system's terminal block labeled **"INPUT"**. **For 2-wire input:** connect hot wire to the input block marked **"Line"**, connect the common wire to the input block marked **"Neutral"** and connect the ground wire to the compression lug next to the input terminal block. **For 3-wire input:** connect each hot wire to each of the input block positions marked **"Line"**, connect the common wire to the input block marked **"Neutral"** and the ground wire to the compression lug next to the input terminal block. **For 4-wire input:** connect each hot wire to each of the input blocks marked **"Line"**. **Phasing must be clockwise rotation** – i.e. Phase B lags Phase A, connect the common wire to the input block marked **"Neutral"** and ground wire to the compression lug next to the input terminal block.

## INSTALLING AC OUTPUT WIRES:

12. Connecting load wires without system distribution circuit breakers – connect load wires to the system's terminal block labeled **"OUTPUT"**. Connect hot wire(s) to the output block marked **"Nor. On"**, the common wire(s) to the output block marked **"Neutral"** and the ground wire(s) to the compression lug next to the output terminal block. Emergency only load hot wires must be connected to the optional circuit on the output terminal block labeled **"Nor. Off"**.

Connecting load wires with system distribution circuit breakers – connect the hot wire from each branch circuit to a circuit breaker and connect the common wire from each branch circuit to the neutral connection bar.

Figure 4.1 AC Input and Output connections

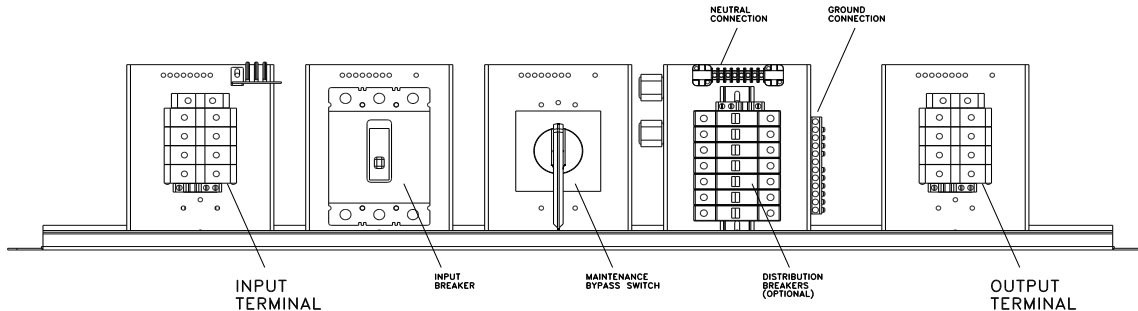

## SECTION 5

# INSTALLING BATTERIES AND DC WIRING

### WARNING

Only qualified service personnel (such as a licensed electrician) should perform the battery and DC wiring installation. Risk of electrical shock.

---

This section explains how to install system batteries, fuses, and cables. An electrician who is familiar with battery installations and applicable building and electrical codes should install the batteries.

### WARNING

The batteries that will need to be installed in this system could cause you harm or severely damage the electronics if proper precautions are not followed. Batteries connected in series parallel configuration could produce lethal voltages with extreme currents. All batteries should be inspected for damage prior to installation. Never install a battery that is leaking electrolyte. Battery terminals should be cleaned with a wire brush to remove any oxidation. All tools should be insulated. Rubber gloves and safety glasses are recommended. **IN THIS SYSTEM BATTERY NEGATIVE IS TIED TO GROUND INSIDE THE INVERTER.** This means that the battery cabinet and shelves are at ground potential as soon as negative connections are made to the batteries. It is strongly recommended to make all negative connections to the batteries the last step to prevent any chance of shorting battery positive to ground. With the DC fuse removed, make connections to battery positive first, working your way towards battery negative. Leave individual strings of batteries open at the last battery negative until all batteries are installed. Then connect each strings negative.

## Safety Instructions

### IMPORTANT SAFETY INSTRUCTIONS

#### SAVE THESE INSTRUCTIONS

This section contains important instructions that a qualified service person should follow during installation and maintenance of the system and batteries. **ONLY** a qualified service person should work with the batteries.

---

### CAUTION

Full voltage and current are always present at the battery terminals. The batteries used in this system can produce dangerous voltages, extremely high currents, and a risk of electric shock. They may cause severe injury if the terminals are shorted together or to ground (earth). You must be extremely careful to avoid electric shock and burns caused by contacting battery terminals or shorting terminals during battery installation. Do not touch un-insulated battery terminals.

A qualified electrician familiar with battery systems and required precautions must install and service the batteries. Any battery used with this unit shall comply with the applicable requirements for batteries in the standard for emergency lighting and power equipment, UL 924 (Canada's National Building Code). Cabinets are design to be used with, and batteries must be replaced with, manufacturer battery number BAT-CG12105 or a manufacturer approved equivalent (see the battery wiring diagram that came with the battery cables). If you substitute batteries not supplied by manufacturer, the unit's UL (cUL) listing is void and the equipment may fail. Installation must conform to national and local codes as well. Keep unauthorized personnel away from batteries.

The electrician must take these precautions:

Wear protective clothing and eyewear. For battery systems >48vdc, wear rubber gloves and boots. Batteries contain corrosive acids or caustic alkalis and toxic materials and can rupture or leak if mistreated. Remove rings and metal wristwatches or other metal objects and jewelry. Don't carry metal objects in your pockets where the objects can fall onto the batteries or into the system or battery cabinet.

Tools must have insulated handles and must be insulated so that they do not short battery terminals. Do not allow a tool to short a battery terminal to another battery terminal or to the cabinet at any time. Do not lay tools or metal parts on top of the batteries, and do not lay them where they could fall onto the batteries or into the cabinet.

Install the batteries as shown on the battery-wiring diagram provided with the system. When connecting cables, never allow a cable to short across a battery's terminals, the string of batteries, or to the cabinet.

Align the cables on the battery terminals so that the cable lug does not contact any part of the cabinet even if the battery is moved. Keep the cable away from any sharp metal edges.

---

### **CAUTION**

Install the battery cables so the system dead front panels cannot pinch them.

Where conductors may be exposed to physical damage, protect conductors in accordance with the National Electrical Code (NEC) [Canadian Electrical Code (CEC)].

If you are replacing batteries or repairing battery connections, follow the procedure in the section 6 to shut down your system and remove both AC and DC input power.

---

## Before Installing the Batteries

### Tools

#### CAUTION

Always use insulated tools when you work with batteries. Always torque connections to the manufacturer's recommendations.

When you work with system batteries, you need the following tools. The tools must be insulated so they do not short battery terminals to the cabinet. Wear the safety equipment required by local code whenever the doors are open and whenever you are working on batteries. Other tools may be necessary for optional batteries.

- Digital volt-ohm meter
- 7/16" open end wrench
- 3" extension socket
- Ratchet
- Wire brush
- Electrical tape
- Conductive grease or petroleum jelly
- Brush (to apply grease or petroleum jelly to terminals)
- Safety equipment required by local codes
- Torque wrench calibrated in inch-pounds or Newton-meters
- 7/16" socket wrench
- Safety glasses with side shields

### Battery Voltage (vdc)

| Models                              | 3.0kW | 4.0kW | 5.0kW | 6.5kW | 8.0kW | 10.0kW |
|-------------------------------------|-------|-------|-------|-------|-------|--------|
| Battery Volts for 90 Minute Systems | 120v  | 144v  | 180v  | 240v  | 144v  | 144v   |

### Battery Cable Sizing

The battery cable or wire used is No. 6 AWG (13.30 mm<sup>2</sup>) for all applications:

### DC Disconnect

Systems have a Main Battery Fuse (F1) inside the cabinet; this fuse lets you remove DC power from the batteries. Systems with two parallel sets of batteries have a fuse in line with the positive cable of each string.

## Installing and Connecting the Batteries

### Battery Wiring Diagram

Refer to the "Battery Interconnect" diagram (pgs.25-29) that corresponds with your systems KVA rating. This battery-wiring diagram shows how you should install the batteries, make terminal, and fuse connections. Use the diagram as you follow the steps below.

### Location

The system batteries are inside the unit. Before you start installing the batteries, you must install the system in its permanent location. If you have not already done this, see "Location Guidelines" on page 11 to choose a location.

## CAUTION

To prevent damage to your equipment, do not move the system after the batteries are installed.

To make sure a location is acceptable for the system, review the requirements in Section 3.

### Electronics Cabinet Battery Block Connections

Do not connect any battery cables at this time. In the following procedure, you should only make connections to the electronics cabinet's battery block. Use the battery-wiring diagram shipped with the battery cables as you follow these steps.

- 1. For systems with a single string of batteries:** Find the positive battery cable that connects to the battery block. At the bare end of the cable, strip off 0.5" (1.3 cm) of insulation. Connect the cable to the battery block. Tighten the connection as shown on the battery-wiring diagram. Insulate the other end of the cable. **For systems with two strings of batteries (8kW and 10kW only):** Repeat this step with second positive battery cable.
- 2. For systems with a single string of batteries:** Find the negative battery cable that connects to the battery block. At both ends of the cable, strip off 0.5" (1.3 cm) of insulation. Connect one end of the cable to the battery block, the other end to the fuse block on the battery shelf. Tighten the connection as shown on the battery-wiring diagram. **For systems with two strings of batteries (8kW and 10kW only):** Repeat this step with second negative battery cable.

### Fuse

All units come with a fuse(s) to protect the system. The battery-wiring diagram shows the fuse location; a label inside the battery cabinet shows the fuse size.

**Verify that the battery fuse(s) in the cabinet is removed before connecting the batteries.**

### Arranging the Batteries

**NOTE** As you arrange the batteries, you must be wearing the required safety equipment.

Arrange the batteries in the cabinet or the system only as shown in the battery-wiring diagram. This arrangement is designed to maximize airflow around the batteries. The cabinets are designed so that battery cases should never touch. Air should be free to circulate. Clean the entire surface of all battery terminals with the wire brush before you install the batteries to create good contact points.

Load the batteries into the system or battery cabinet(s). Starting with the bottom shelf, load one shelf at a time.

## CAUTION

Never install the batteries in an airtight enclosure.

## Connecting the Cables Between Batteries

When you make battery terminal connections, use the torque wrench to tighten the battery terminal connections securely. For most batteries, you can find out what torque value to use by finding the battery number on the front of the battery. Then, use Table 5.1 to find the torque value for that battery.

Now, follow these steps to connect the cables:

**Table 5.1 Battery Torque**

| Battery Type                 | Torque                          |
|------------------------------|---------------------------------|
| BAT-CG12105 or SL-12105      | Torque to 120 in lbs. (13.6 Nm) |
| BAT-CG12105A or SL-12105M    | Torque to 120 in lbs. (13.6 Nm) |
| BAT-CG12105B                 | Torque to 55 in lbs. (6.5 Nm)   |
| BAT-CG12105E or 12AVR100-3ET | Torque to 100 in lbs. (11.3 Nm) |
| BAT-CG12105G                 | Torque to 100 in lbs. (11.3 Nm) |
| BAT-CG12105H or FT12-105     | Torque to 110 in lbs. (12.4 Nm) |

1. Using the battery-wiring diagram, determine which batteries belong to each battery string.

**NOTE:** For standard 90-minute runtimes, 3kW, 4kW, 5kW, 6.5kW models have only one battery string. 8kW and 10kW models have two battery strings.

2. Clean the cable connectors with the wire brush before you make the battery connections.

**NOTE** As you carry out the following step, use these guidelines:

*If you are using conductive grease, apply a thin coating of high-temperature conductive grease on each post and every cable connector before you assemble and torque the connection to slow corrosion.*

*If you use nonconductive grease like petroleum jelly, do not apply any grease before you make the connections and torque them. Instead, make the connection first; then, torque it to the value shown in Table 5.1. After you make the connection, apply a coating of the nonconductive grease to the hardware at the battery terminals.*

3. In each battery string, connect the battery cables between the batteries as shown in the battery-wiring diagram (positive terminal to negative terminal). Torque the connections to the value shown for your battery in Table 5.1.
4. Connect the battery cables from one shelf to the next as shown on the battery-wiring diagram.
5. Connect the fuse block to the negative of the battery as shown on the battery-wiring diagram.

### CAUTION

Hazardous voltage is present! System batteries are high current sources. These batteries can produce dangerous voltages, extremely high currents, and a risk of electric shock.

6. Install only the battery string fuses (on the battery shelf). Next, use the voltmeter to check the DC voltage between the negative (-) position on the battery block and the unconnected battery positive terminal. This voltage should be approximately the battery voltage record on the unit ID label. If it is greater than + or – 5% Vdc, review the battery wiring diagram. Correct any wiring errors and recheck the DC voltage; do not go on until your measurement is within + or – 5% Vdc. If the measurement is too high and you cannot find the cause of the problem, call SERVICE.

#### **CAUTION**

If you do not verify that voltage and current direction are correct, the equipment may fail.

---

### **Connecting the Positive Battery Cable(s) to the Battery String(s)**

Remove the insulation from the cable that was put on in step 2 of “Electronics cabinet battery block connections”. Connect the cable to the battery positive (+). Repeat this step for systems with 2 strings.

## **Replacing the Batteries**

#### **CAUTION**

A battery can present a risk of electrical shock and high short circuit current. A qualified electrician familiar with battery systems should service the batteries.

---

Review all the safety instructions at the beginning of this chapter before you replace any batteries.

### **Use the Same Quantity and Type of Battery**

#### **CAUTION**

You must use the same quantity and type of battery. Substituting batteries not supplied by manufacturer voids the UL (CUL) listing and may cause equipment damage.

---

To ensure continued superior performance of your system and to maintain proper charger operation, you must replace the batteries in the system or battery cabinets with the same number of batteries. These batteries must be the same types as the original batteries. The replacement batteries should have the same voltage and ampere-hour rating as the original batteries.

### **Handle Used Batteries with Care!**

Assume that old batteries are fully charged. Use the same precautions you would use when handling a new battery. Do not short battery terminals or the battery string with a cable or tool when you disconnect the batteries! Batteries contain lead. Please dispose of old batteries properly.



### **CAUTION**

Do not dispose of batteries in a fire because the batteries could explode. Do not open or mutilate batteries. Released electrolyte is harmful to the skin and eyes. It may be toxic.

### **Dispose of Batteries Properly**

### **CAUTION**

Batteries contain lead. Many state and local governments have regulations about used battery disposal. Please dispose of the batteries properly.

- CAUTION:**
- 1- BEFORE WIRING TO INVERTER, TURN INSTALLATION SWITCH TO OFF AND REMOVE DC FUSE.
  - 2- CUT ITEMS 3 - 5 TO MINIMUM LENGTH.
  - 3- OBSERVE POLARITY, CONNECT BATTERIES AS SHOWN.
  - 4- FOLLOW START-UP PROCEDURE IN SYSTEM MANUAL.

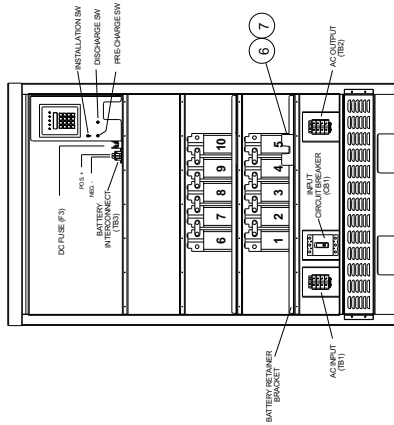

**DOORS, COVERS OMITTED FOR CLARITY**

NOTE:  
 REMOVE BATTERY/SCANNER BRACKET BEFORE  
 AND AFTER WIRING FOR INSTALLATION.

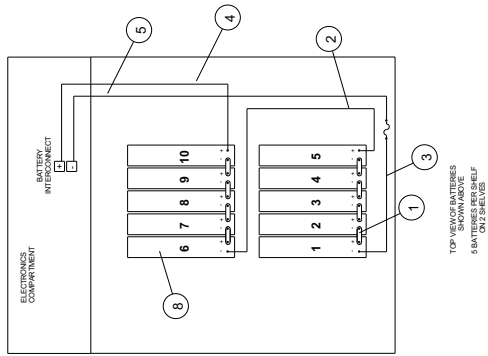

**3.0kVA @ 90 MINUTE RUN TIME**



| ITEM NO. | DESCRIPTION       | QTY. | PART NO.       |
|----------|-------------------|------|----------------|
| 8        | BATTERY           | 10   | BAT-CG12105    |
| 7        | FUSE BLOCK        | 1    | F-B060-0250    |
| 6        | FUSE              | 1    | FNLN050250B    |
| 5        | CABLE 6 GA. 60LG. | 1    | W-B060+060B0   |
| 4        | CABLE 6 GA. 48LG. | 1    | W-B048+060L1   |
| 3        | CABLE 6 GA. 36LG. | 1    | W-B036+060L1   |
| 2        | CABLE 6 GA. 66LG. | 1    | W-B066+060L2   |
| 1        | INTERCONNECT      | 8    | W-INTERC0600B0 |

| REV. | DATE | BY | DESCRIPTION |
|------|------|----|-------------|
| X    | X    | X  |             |
| X    | X    | X  |             |
| X    | X    | X  |             |

|  |   |                               |
|--|---|-------------------------------|
| SCALE: 1 = 1/8"                                  | ALL DIMENSIONS ARE SHOWN IN INCHES.                             | DRAWN BY: K W                 |
| DATE: 06/25/05                                   | IF UP-ANGULAR ALL DIM TO ALL DIM TOL UNLESS OTHERWISE SPECIFIED | APPROVED BY:                  |
| <b>BATTERY INTERCONNECT, "C-3R", FRONT MOUNT</b> |   |                               |
| <b>3.0k @ 90 MIN.</b>                            |   | DRAWING NUMBER: <b>303399</b> |

- CAUTION:**
- 1- BEFORE WIRING TO INVERTER, TURN INSTALLATION SWITCH TO OFF AND REMOVE DC FUSE.
  - 2- CUT ITEMS 3 - 5 TO MINIMUM LENGTH.
  - 3- OBSERVE POLARITY, CONNECT BATTERIES AS SHOWN.
  - 4- FOLLOW START-UP PROCEDURE IN SYSTEM MANUAL.

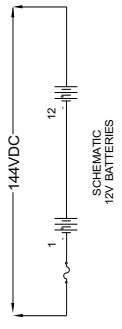
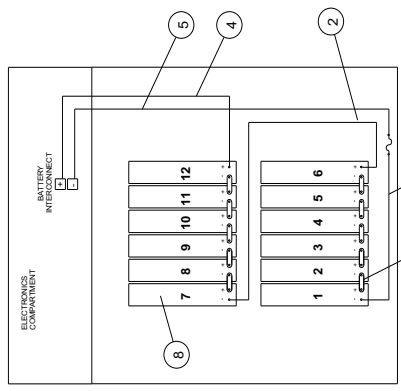
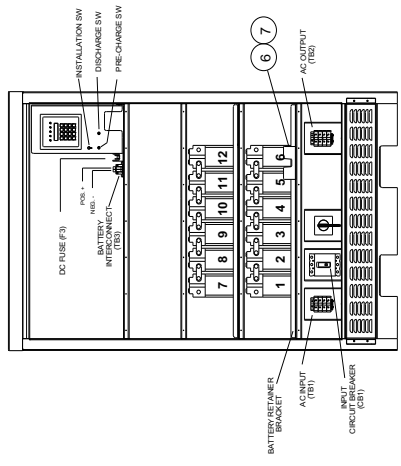

**4.0kVA @ 90 MINUTE RUN TIME**

**DOORS, COVERS OMITTED FOR CLARITY**

NOTE: REMOVE BATTERY RETAINER BRACKET BEFORE AND REPLACE AFTER BATTERY INSTALLATION

| ITEM NO. | DESCRIPTION       | QTY. | PART NO.              |
|----------|-------------------|------|-----------------------|
| 8        | BATTERY           | 12   | BAT-CG12105           |
| 7        | FUSE BLOCK        | 1    | F-B060-0250           |
| 6        | FUSE              | 1    | FNLN050250B           |
| 5        | CABLE 6 GA. 60LG. | 1    | W-B060+060B0          |
| 4        | CABLE 6 GA. 48LG. | 1    | W-B048+060L1          |
| 3        | CABLE 6 GA. 36LG. | 1    | W-B036+060L1          |
| 2        | CABLE 6 GA. 66LG. | 1    | W-B066+060L2          |
| 1        | INTERCONNECT      | 10   | MANUFACTURER PROVIDED |

| SCALE:                                       | 1" = 15" | ALL DIMENSIONS ARE DRAWN IN INCHES UNLESS OTHERWISE SPECIFIED. |
|--|----------|--|
| DATE:  | 08/23/05 | UNLESS OTHERWISE SPECIFIED.                                    |
| DRAWN BY: K W                                |          |  |
| APPROVED BY:                                 |          |  |
| BATTERY INTERCONNECT, "C-C3-3R", FRONT MOUNT |          |  |
| 4.0kVA @ 90 MIN.                             |          |  |
| DRAWING NUMBER: 303404                       |          |  |

| REV. | DATE | BY | DESCRIPTION |
|------|------|----|-------------|
| X    |      | X  |             |
| X    |      | X  |             |

- CAUTION:**
- 1- BEFORE WIRING TO INVERTER, TURN INSTALLATION SWITCH TO OFF AND REMOVE DC FUSE.
  - 2- CUT ITEMS 3-5 TO MINIMUM LENGTH.
  - 3- OBSERVE POLARITY, CONNECT BATTERIES AS SHOWN.
  - 4- FOLLOW START-UP PROCEDURE IN SYSTEM MANUAL.

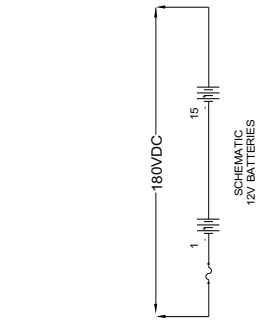

5.0kVA @ 90 MINUTE RUN TIME

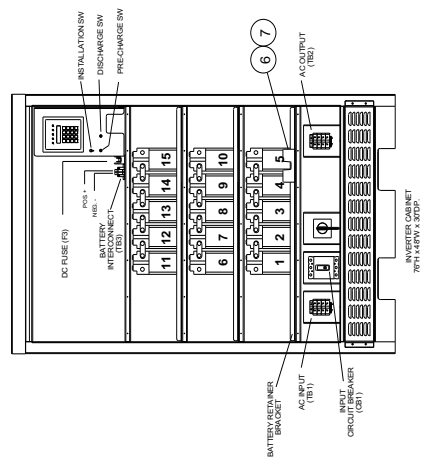
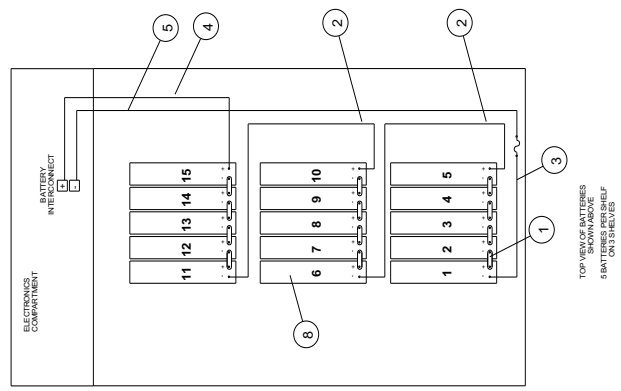

**DOORS, COVERS OMITTED FOR CLARITY**

NOTE: REMOVE BATTERY RETAINER BRACKET BEFORE AND REPLACE AFTER BATTERY INSTALLATION

| REV | DATE | BY | DESCRIPTION |
|-----|------|----|-------------|
| X   | X    | X  |             |
| X   | X    | X  |             |
| X   | X    | X  |             |
| X   | X    | X  |             |

| QTY. | DESCRIPTION  | MANUFACTURER PROVIDED | PART NO.     |
|------|--------------|-----------------------|--------------|
| 15   | BATTERY      | SL-12105              | BAT-CG12105  |
| 1    | FUSE BLOCK   | F-8060-0250           | F-8060-0250  |
| 1    | FUSE         | FNLN050250B           | FNLN050250B  |
| 6    | CABLE        | 6 GA. 60LG.           | W-B060+060B0 |
| 6    | CABLE        | 6 GA. 12LG.           | W-B012+060L1 |
| 6    | CABLE        | 6 GA. 36LG.           | W-B066+060L1 |
| 2    | CABLE        | 6 GA. 66LG.           | W-B066+060L2 |
| 12   | INTERCONNECT |                       |              |

| SCALE: | 1" = 15' | ALL DIMENSIONS ARE IN INCHES UNLESS OTHERWISE SPECIFIED.                 | DRAWN BY:    | KW |
|--------|----------|--|--------------|----|
| DATE:  | 08/23/05 | 1/8" ANGULAR ALL DIM. TO WALL DIM. TO CENTER UNLESS OTHERWISE SPECIFIED. | APPROVED BY: |    |

  

| DRAWING NUMBER                               |        |
|--|--------|
| BATTERY INTERCONNECT, "C-C3-3R", FRONT MOUNT | 303405 |

BATTERY INTERCONNECT, "C-C3-3R", FRONT MOUNT

5.0kVA @ 90 MIN.

- CAUTION:**
- 1- BEFORE WIRING TO INVERTER, TURN INSTALLATION SWITCH TO OFF AND REMOVE DC FUSE.
  - 2- CUT ITEMS 3-5 TO MINIMUM LENGTH.
  - 3- OBSERVE POLARITY, CONNECT BATTERIES AS SHOWN.
  - 4- FOLLOW START-UP PROCEDURE IN SYSTEM MANUAL.

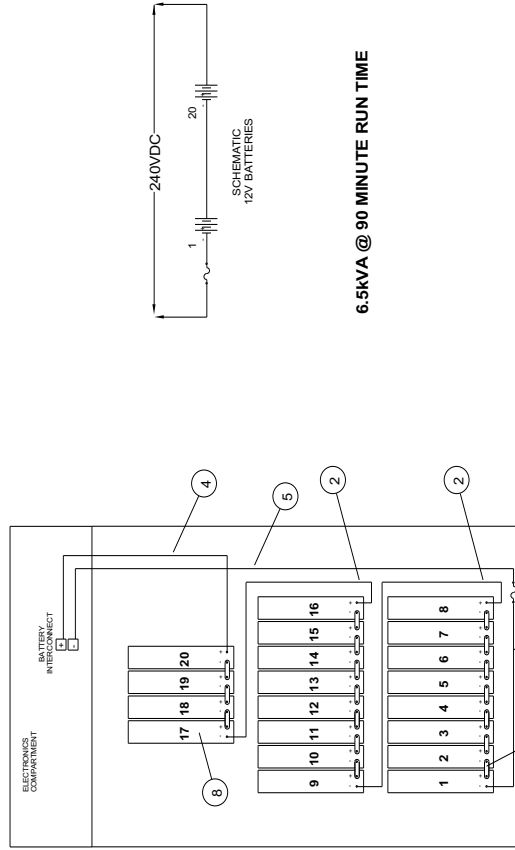

6.5kVA @ 90 MINUTE RUN TIME

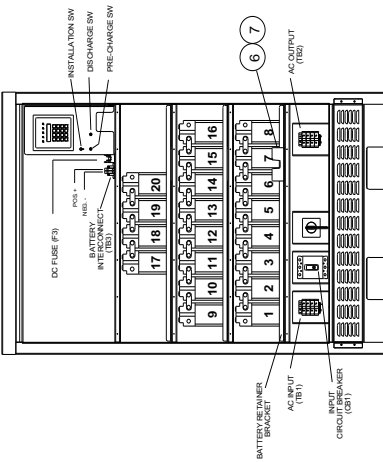

**DOORS, COVERS OMITTED FOR CLARITY**

NOTE:  
REMOVE BATTERY RETAINER BRACKET BEFORE  
AND REPLACE AFTER BATTERY INSTALLATION

| ITEM NO. | DESCRIPTION  | QTY.        | PART NO.              |
|----------|--------------|-------------|-----------------------|
| 8        | BATTERY      | 20          | BAT-CG12105           |
| 7        | FUSE BLOCK   | 1           | F-B060-0250           |
| 6        | FUSE         | 1           | FNLN050250B           |
| 5        | CABLE        | 6 GA. 60LG  | W-B060+060B0          |
| 4        | CABLE        | 6 GA. 12LG. | W-B012+060L1          |
| 3        | CABLE        | 6 GA. 36LG. | W-B036+060L1          |
| 2        | CABLE        | 6 GA. 66LG. | W-B066+060L2          |
| 1        | INTERCONNECT | 17          | MANUFACTURER PROVIDED |

| REV. | DESCRIPTION | DATE | BY |
|------|-------------|------|----|
| X    | X           | X    | X  |
| X    | X           | X    | X  |
| X    | X           | X    | X  |
| X    | X           | X    | X  |

|  |  |              |                 |
|--|--|--------------|-----------------|
| SCALE: 1" = 15"                              | ALL DIMENSIONS ARE SHOWN IN INCHES                 | DRAWN BY:    | K.W.            |
| DATE: 09/23/05                               | RESISTANCE TO 15° ANGLE UNLESS OTHERWISE SPECIFIED | APPROVED BY: |                 |
| BATTERY INTERCONNECT, "C/C3-3P", FRONT MOUNT |  |              | DRAWING NUMBER: |
| 6.5kVA @ 90 MIN.                             |  |              | 303406          |

**CAUTION:**

- 1—BEFORE WIRING TO INVERTER, TURN INSTALLATION SWITCH TO OFF AND REMOVE DC FUSE.
- 2—CUT ITEMS 3 – 8 TO MINIMUM LENGTH.
- 3—OBSERVE POLARITY, CONNECT BATTERIES AS SHOWN.
- 4—FOLLOW START-UP PROCEDURE IN SYSTEM MANUAL.

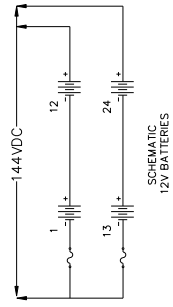
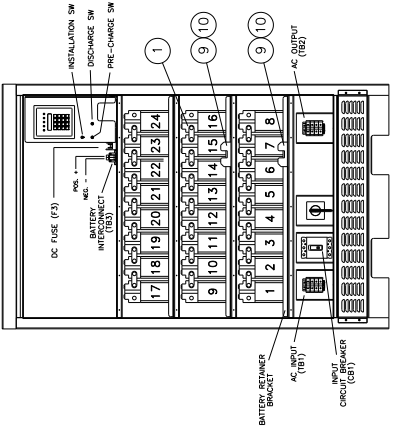
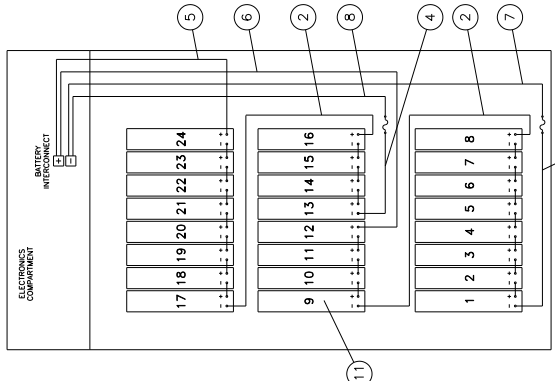

8.0kVA @ 90 MINUTE RUN TIME  
 10.0kVA @ 90 MINUTE RUN TIME

DOORS, COVERS OMITTED FOR CLARITY

NOTE:  
 REMOVE BATTERY RETAINER BRACKET BEFORE  
 AND REPLACE AFTER BATTERY INSTALLATION

|                |               |    |                       |
|----------------|---------------|----|-----------------------|
| 11 BATTERY     | SL-12105      | 24 | BAT-CG12105           |
| 10 FUSE BLOCK  |               | 2  | F-B060-0250           |
| 9 FUSE         |               | 2  | FNLN050250B           |
| 8 CABLE        | 6 GA. 48" LG. | 1  | W-B048+060B0          |
| 7 CABLE        | 6 GA. 60" LG. | 1  | W-B060+060B0          |
| 6 CABLE        | 6 GA. 60" LG. | 1  | W-B060+060L1          |
| 5 CABLE        | 6 GA. 24" LG. | 1  | W-B024+060L1          |
| 4 CABLE        | 6 GA. 18" LG. | 1  | W-B018+060L1          |
| 3 CABLE        | 6 GA. 36" LG. | 1  | W-B036+060L1          |
| 2 CABLE        | 6 GA. 66" LG. | 2  | W-B066+060L2          |
| 1 INTERCONNECT |               | 20 | MANUFACTURER PROVIDED |

|  |             |              |   |
|--|-------------|--------------|---|
| ITEM NO.                                       | DESCRIPTION | QTY.         | PART NO.                                |
| SCALE: 1 = 15                                  |             |              |   |
| DATE: 08/23/05                                 |             |              |   |
| DRAWN BY: K. W.                                |             | APPROVED BY: |   |
| BATTERY INTERCONNECT, "C"/"C3-3R", FRONT MOUNT |             |              |   |
| DRAWING NUMBER: 303407B                        |             |              |   |
| REV.   | DATE        | BY           | DESCRIPTION                             |
| B  | 08/11/21    | NF           | ADDED 10.0KVA                           |
| A  | 02/21/18    | KW           | REVISED BATTERY INTERCONNECT SCHEMATIC. |
| 8.0kVA & 10.0kVA @ 90 MIN.                     |             |              |   |

## SECTION 6

# STARTUP AND SHUTDOWN PROCEDURE

### STARTUP PROCEDURE

**CAUTION: HAZARDOUS VOLTAGES – ONLY QUALIFIED SERVICE PERSONNEL SHOULD PERFORM PROCEDURE.**

1. Verify that the installation switch (S1) located on the inverter chassis and the system AC Input Circuit Breaker (CB1) are in the OFF position.
2. Turn on AC input at the building service center.
3. Locate the DC Pre-charge Switch (S2), see fig.6.1; press it for five seconds; then, install the battery fuse (F1) inside the electronics cabinet. If a large flash occurs, the batteries are not connected properly. Call service immediately.
4. Turn on the systems Input Circuit Breaker (CB1). (See fig. 4.1)
5. Turn the installation switch (S1) to the ON position. Leave the loads (protected equipment) off. System will run on batteries, then transfer to normal mode.
6. Turn on loads

### SHUTDOWN PROCEDURE

1. Interrupt the AC Mains to the machine by the Distribution Panel Breaker or the systems input circuit breaker. The Inverter should then start.
2. Turn the installation switch located on the inverter chassis to the off position. The inverter should stop.
3. Disconnect the main battery fuse located on the inverter chassis.

**CAUTION: HAZARDOUS VOLTAGES STILL EXIST AT THE BATTERY TERMINAL BLOCK AND WITHIN THE SYSTEM. AUTHORIZED SERVICE TECHNICIANS MUST DISCHARGE DC CAPACITORS AND TURN OFF UTILITY POWER BEFORE SERVICING EQUIPMENT. CAUTION: DO NOT LEAVE THE SYSTEM SHUTDOWN FOR A PROLONGED LENGTH OF TIME. LEAD BASED BATTERIES WILL EXPERIENCE PERMANENT DAMAGE FROM LACK OF CHARGING AFTER A FEW MONTHS.**

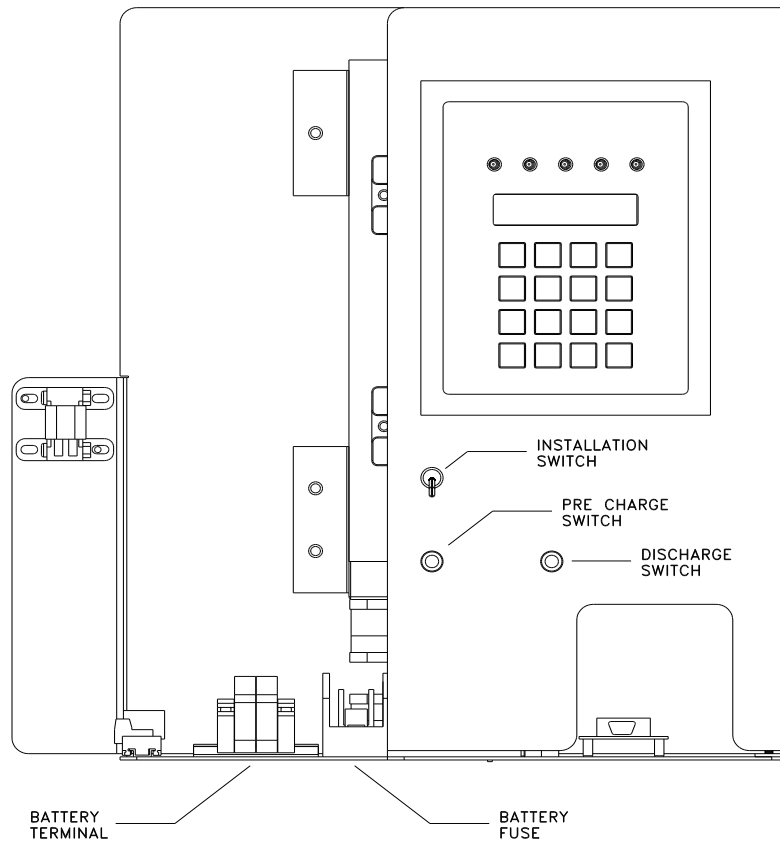

**Figure 6.1 Battery Fuse, DC Pre-charge Switch, DC Discharge Switch & Installation Switch**



# MAINTENANCE BYPASS PROCEDURE

## CAUTION:

**HAZARDOUS VOLTAGES – ONLY QUALIFIED SERVICE PERSONNEL SHOULD PERFORM PROCEDURE.**

### System Into Bypass Mode

1. Open System doors. Locate Maintenance Bypass Switch.
2. Turn Maintenance Bypass Switch handle from normal mode (**UPS**) to bypass mode (**BYPASS**).
3. Locate Installation Switch. Turn the Installation Switch to the (**OFF**) position.
4. Locate Input Circuit Breaker (CB1). Turn the Input circuit Breaker to the (**OFF**) position.
5. Locate Main Battery Fuse behind top dead front panel on chassis. Remove Main Battery fuse.

## CAUTION:

**HAZARDOUS VOLTAGES STILL EXIST AT THE BATTERY TERMINAL BLOCK AND WITHIN THE SYSTEM. AUTHORIZED SERVICE TECHNICIANS MUST DISCHARGE DC CAPACITORS BEFORE SERVICING EQUIPMENT. LOCATE DISCHARGE SWITCH. PRESS IT FOR 10 SECONDS.**

## WARNING:

**DO NOT LEAVE THE SYSTEM SHUTDOWN FOR A PROLONGED LENGTH OF TIME. LEAD BASED BATTERIES WILL EXPERIENCE PERMANENT DAMAGE FROM LACK OF CHARGING.**

**Remove all Battery String Fuses from Fuse Holders behind dead front panels.**

### System On Line From Bypass Mode

1. Verify that the Installation Switch is in the (**OFF**) position.
2. Install all Battery String Fuses.
3. Press and hold DC Pre-charge switch for approximately five seconds and then install the Main Battery Fuse on the inverter chassis. If a large flash occurs, the batteries are not connected properly. Call service immediately.
4. Turn the Input Circuit Breaker (CB1) to the (**ON**) position.
5. Turn the Installation Switch to the (**ON**) position. The Front Panel Display will now be illuminated and a slight hum should be heard from the inverter transformer. The unit is now charging the batteries.
6. Turn the Maintenance Bypass Switch handle from bypass mode (**BYPASS**) to normal mode (**UPS**). The emergency equipment is now protected by the inverter system.
7. Install dead front panels.

## SECTION 7

# OPERATION

The following is a description of the status LED's located on the front panel (Fig. 8.1).

### **AC Present**

When the AC Mains is present, the LED will illuminate. If a power failure was long in duration, or the AC mains was disconnected by some other means (Circuit breaker open) the AC Present LED would not be illuminated. When the control circuit senses that the line has dropped below an acceptable level (Black Out, Brown Out, or Transient), the inverter will energize for at least one minute. So, if the power failure was a momentary glitch, the AC present LED would be illuminated but the inverter would be running.

### **System Ready**

When the system has adequate battery voltage to transfer, the System Ready LED will illuminate. This feature prevents damage from multiple deep discharges of the battery.

### **Battery Charging**

When the AC Mains is connected to the line and the battery is charging under normal conditions, the Battery Charging LED will illuminate.

### **Battery Power**

When the inverter is producing output power (battery is being discharged), the Battery Power LED will be illuminated.

### **Fault**

This is a summary Fault indication. When there is a fault condition present, the Fault LED will illuminate. To view which fault is present, use the keypad and LCD display feature.

The front panel display will provide the user with a variety of information. It has a full compliment of Meter functions, Control functions and Program functions.

## SECTION 8

# FRONT PANEL DISPLAY

The Front panel consists of a 2 x 20 alphanumeric LCD display with LED Back lighting, 5 Status LED indicators and a 4 x 4 keypad for user interface. Several parameters in the system software determine when and how your system conducts the automatic monthly and annual tests. Refer to "Program Functions" for a description of each test.

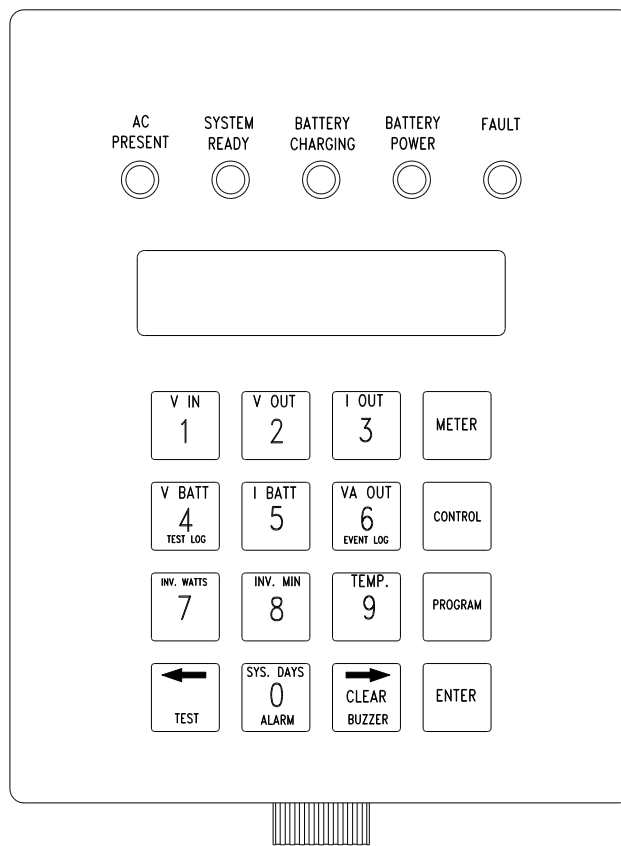

**Figure 8.1 Front Panel Display**

## Control Panel Keypads

**Table 8.1 Keypad Functions**

| Key Name            | Description  |
|---------------------|--|
| Meter (Blue)        | Pressing this key will activate Meter Functions  |
| Control (Red)       | Pressing this key will activate Control Functions  |
| Program (Black)     | Using this key, you can enter passwords or change parameter values. To enter passwords, press [PROGRAM], enter the password, and press [ENTER]. NOTE: A password must be entered to change parameters. |
| Enter (Grey)        | This key records or enters a task you perform using the control panel keys.  |
| [ ◀ ]               | This key functions as Left scroll key  |
| [ ▶ ]               | This key functions as Right scroll key   |
| [ 0 ]               | This key works as a number key; it is also used to display active alarms when in CONTROL Mode.   |
| [ 1 ] through [ 9 ] | These keys work as number keys.  |

## Meter Functions

Meter functions are available by pressing the **METER** keypad to get to the Meter Menu and then pressing the desired function keypad. (See figure 8.1)

**Table 8.2 Meter Functions**

| Function         | Description   | Keypad Text |
|------------------|---|-------------|
| Voltage Input    | Measures the AC Input Voltage to the Inverter   | V IN        |
| Voltage Output   | Measures the AC Output Voltage from the Inverter  | V OUT       |
| Current Output   | Measures the AC Output Current from the Inverter. If optional Normally Off loads are connected, it will read the sum of Normally On and Normally Off outputs. Indicates only 120v current or 277v current for 3-wire systems. | I OUT       |
| Battery Voltage  | Measures Battery Voltage  | V BATT      |
| Battery Current  | Measures the Battery Current. When in charge mode, the current will be positive. When in Inverter mode, the current will be negative.   | I BATT      |
| VA Output        | Multiplication of the output voltage and output current   | VA OUT      |
| Inverter Watts   | Multiplication of the battery voltage and the battery current   | INV. WATTS  |
| Inverter Minutes | Total minutes the system has run on inverter  | INV. MIN    |
| Temperature      | Measures the ambient temperature of the electronics enclosure.  | TEMP        |
| System Days      | Total days the system has been in service.  | SYS. DAYS   |

## Control Functions

Control functions are available by pressing "CONTROL" to get to the Control Menu and then pressing the desired function.

**Table 8.3 Control Functions**

| Function       | Keypad Text |
|----------------|-------------|
| Test Log       | TEST LOG    |
| Event Log      | EVENT LOG   |
| Initiate Test  | TEST        |
| Alarm Log      | ALARM       |
| Buzzer Silence | BUZZER      |

- TEST LOG - View the Test Log of the last 75 monthly or Yearly Tests. View the Date, Time, Duration, Output Voltage, Output Current, Temperature and Fault Status.  
Use the left and right scroll key to change event number.  
Use the ENTER key to select desired event number.  
Use the left and right scroll key to view event information about the event.  
Use the TEST LOG key to return to the event number.
- EVENT LOG - Identical to the TEST LOG except this log records the past 75 events.
- TEST - Pressing the TEST key will initiate a 1-minute test. This test will be recorded in the Event log since it is not part of the scheduled monthly or yearly test.
- ALARM - View the Alarm log of the last 50 alarms. View the Date, Time and Alarm.  
Use the left and right scroll key to change alarm number.  
Use the enter key to select alarm number.  
Use the left and right scroll key to view information about the alarm.  
Use the ALARM key to return to event number.
- BUZZER - Pressing this key silences the audible buzzer from a fault condition or an intermittent beep when the inverter is under battery power. If a fault caused the buzzer to alarm and the alarm is silenced, the buzzer will return after 24 hours or after the fault is cleared.

## Program Functions

### User Program Functions

All program functions are password protected. The password for user level is 1234. When the PROGRAM keypad is pressed, the display will prompt the user for the password. After the password is entered (1234 + ENTER key), the user can change the Date, Time, Month Test Date, Month Test Time, Yearly Test Date and Yearly Test Time, Load Reduction Fault, Low VAC Alarm, High VAC Alarm, Ambient Temp Alarm and Near Low Battery settings. Time is always in the 24 hour standard. Example 4:00 PM is 16:00.

**Table 8.4 Program Functions**

| Parameter          | Format                       | Factory Default               |
|--------------------|------------------------------|-------------------------------|
| Date               | MM/DD/YY (Month, Date, Year) | Current Date                  |
| Time               | HH/MM (Hours, Minutes)       | Eastern Stand Time            |
| Monthly Test Date  | DD (Date)                    | 15 <sup>th</sup> of the Month |
| Monthly Test Time  | HH/MM (Hours, Minutes)       | 5:00                          |
| Yearly Test Date   | MM (Month)                   | 01                            |
| Yearly Test Time   | HH/MM (Hours, Minutes)       | 8:00                          |
| Load Reduction     | AAAA(Amps)                   | 0.0A                          |
| Low VAC Alarm      | VVVV(Volts)                  | 1.0V                          |
| High VAC Alarm     | VVVV(Volts)                  | 999.9V                        |
| Ambient Temp Alarm | DDD(Degrees Centigrade)      | 70°C                          |
| Near Low Battery   | VVVV(Volts)                  | See Table 8.5                 |

- Near Low Battery Voltage is in VVVV (Volts). The last digit entered is after the decimal place. I.E. (430 + ENTER) will register 43.0VDC. Please refer to table 8.5.
- Load Reduction Fault is in AAAA (Amps). The last digit entered is after the decimal place. I.E. (480 + ENTER) will register 48.0 Amps. If the output current under battery power is 10 percent below this number, the alarm will be set.
- Low AC Voltage Alarm is in VVVV (Volts). The last digit entered is after the decimal place. I.E. (1200 + ENTER) will register 120.0 Volts. If the Input AC Voltage goes below this number the alarm will be set.
- High AC Voltage Alarm is similar to Low AC Voltage Alarm.
- Ambient Temperature Alarm is in DDD (Degrees Centigrade). I.E. (75 + ENTER) will register 75 deg. C. When the ambient temperature internal to the inverter enclosure goes above the set point the alarm will be set.

**Table 8.5 Near Low Battery Voltages**

| DC Voltage | Near Low Battery |
|------------|------------------|
| 120VDC     | 108VDC           |
| 144VDC     | 130VDC           |
| 180VDC     | 162VDC           |
| 240VDC     | 216VDC           |

## The Day of the Automatic Tests

Table 8.8 shows the purpose of each parameter and its factory setting.

**Table 8.6 Factories Setting for Automatic Test Parameter**

| Parameter    | Determines...  | Factory Default            |
|--------------|--|----------------------------|
| Monthly Test | The time and the day of the month for the monthly tests. | 15 <sup>th</sup> @ 5:00 AM |
| Yearly Test  | The time and the date for the yearly test.               | (January) 1 @ 8:00 AM      |

## The Length of the Automatic Tests

Parameters Monthly Test and Yearly Test determine how long the battery test is. Table 8.7 shows the purpose of each parameter.

**Table 8.7 Factories Setting for Automatic Test Parameters**

| Parameter    | Purpose               | Factory Default for 90 minute systems |
|--------------|-----------------------|---------------------------------------|
| Monthly Test | Monthly battery test. | 5 Minutes                             |
| Yearly Test  | Yearly battery test.  | 90 Minutes                            |

The factory can only reprogram these parameters.

If you would like to change the setting of any of the above parameters, (see table 8.4) follow these steps: (i.e. setting the Time). See Figure 8.1 for Keypad location.

1. Press the **PROGRAM** keypad, enter the user password (**1234**), press the **ENTER** keypad.
2. Press the ► arrow keypad (◀ or ► keypads are used for scrolling through the menu) to the Time parameter (HH/MM) to set the time. **NOTE:** Factory default is Eastern Standard Time and with 24 hour formats. (i.e. 1:00 PM = 1300 hours)
3. Enter correct time for your time zone using the NUMBER keypads, and then press the **PROGRAM** keypad to exit.

## SECTION 9

### OPTIONS

#### **1-PHASE SYSTEM: 1-POLE OUTPUT CIRCUIT BREAKER DEVIATION SCHEMATIC**



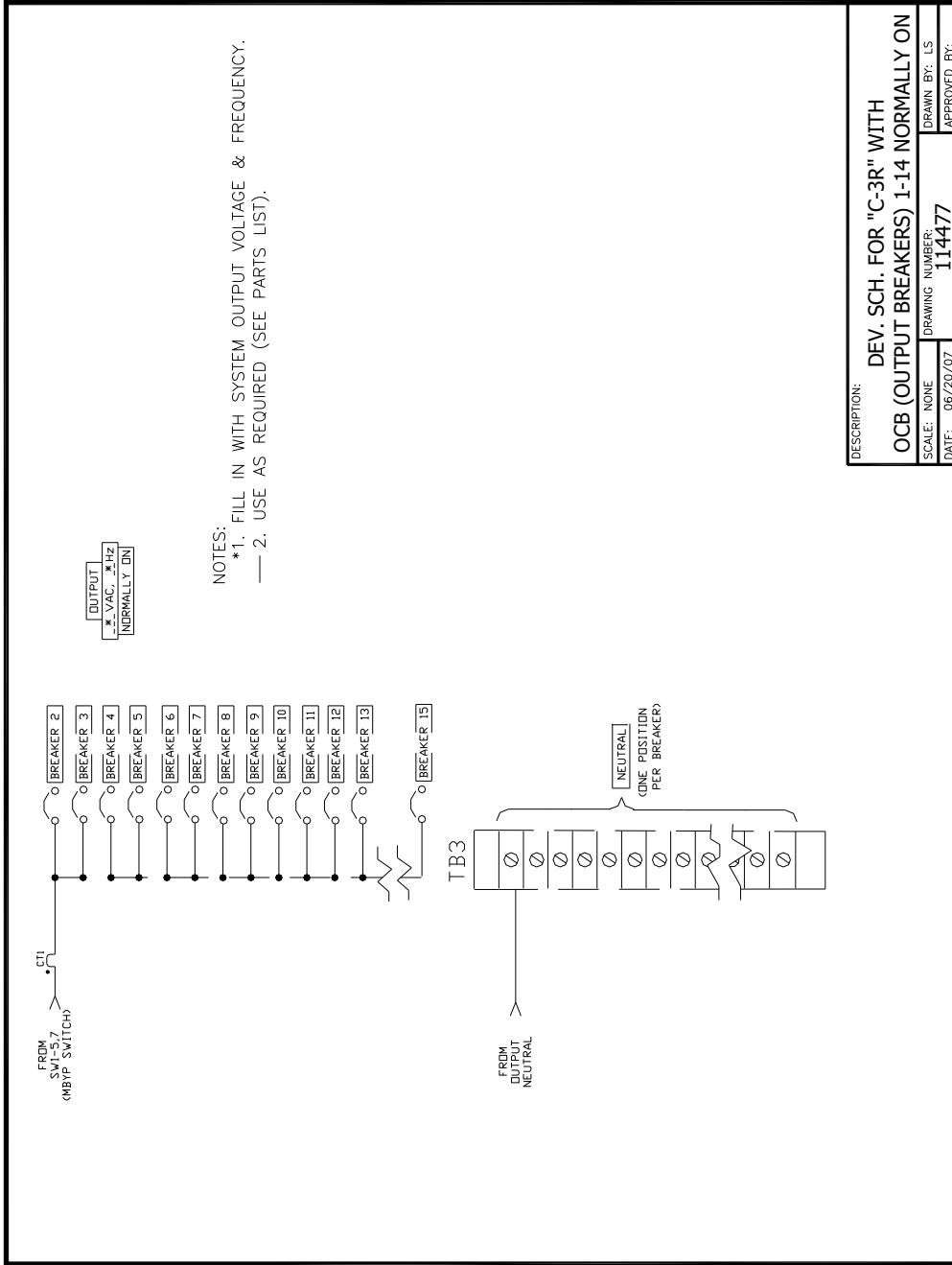

|  |                              |
|--|------------------------------|
| DESCRIPTION:   |                              |
| DEV. SCH. FOR "C-3R" WITH OCB (OUTPUT BREAKERS) 1-14 NORMALLY ON |                              |
| SCALE: NONE  | DRAWING NUMBER: 114477       |
| DATE: 06/25/07   | DRAWN BY: LS<br>APPROVED BY: |

# 3-PHASE SYSTEM: 1-POLE OUTPUT CIRCUIT BREAKER DEVIATION SCHEMATIC

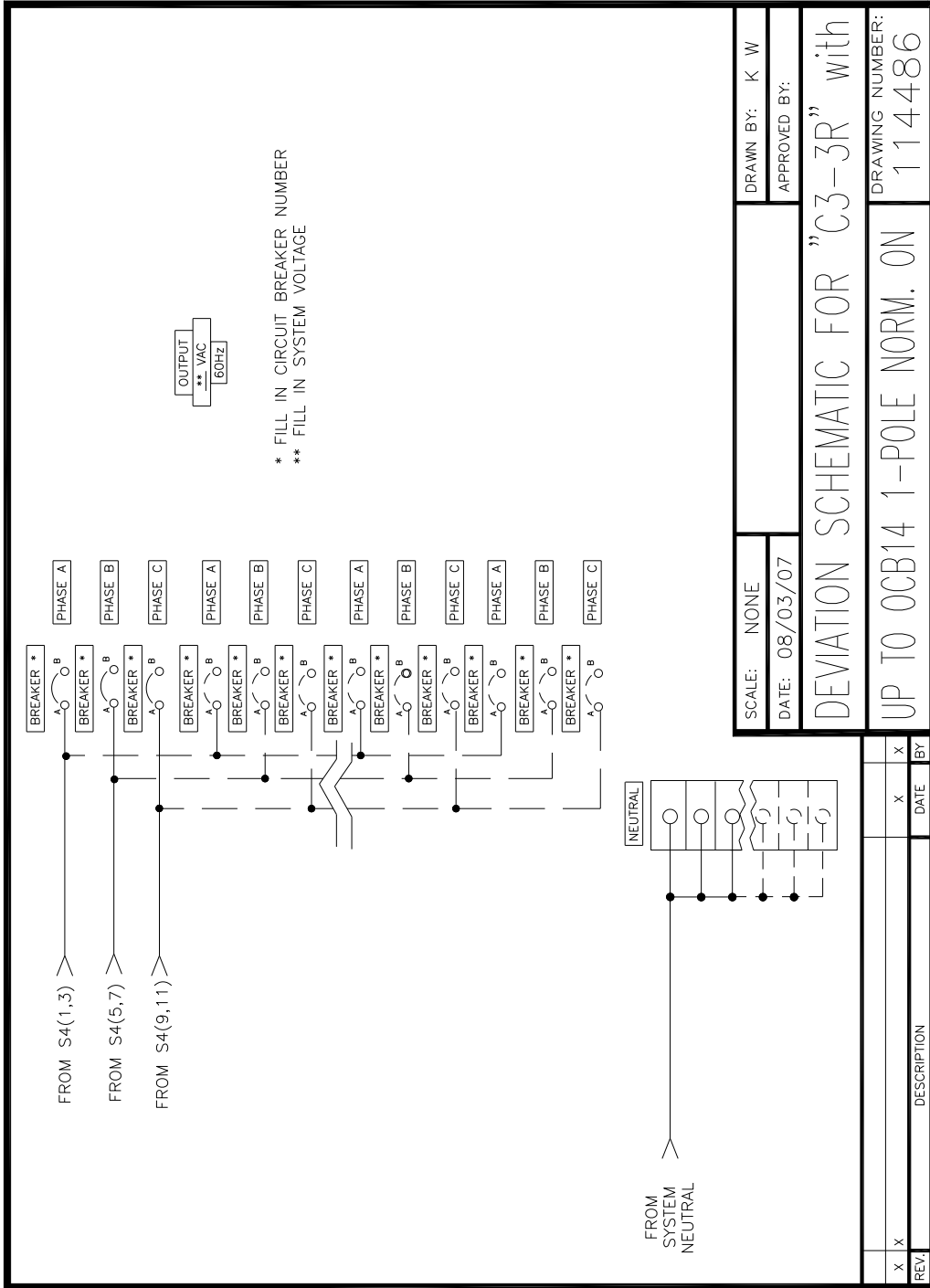

# SUMMARY DRY CONTACT DEVIATION SCHEMATIC

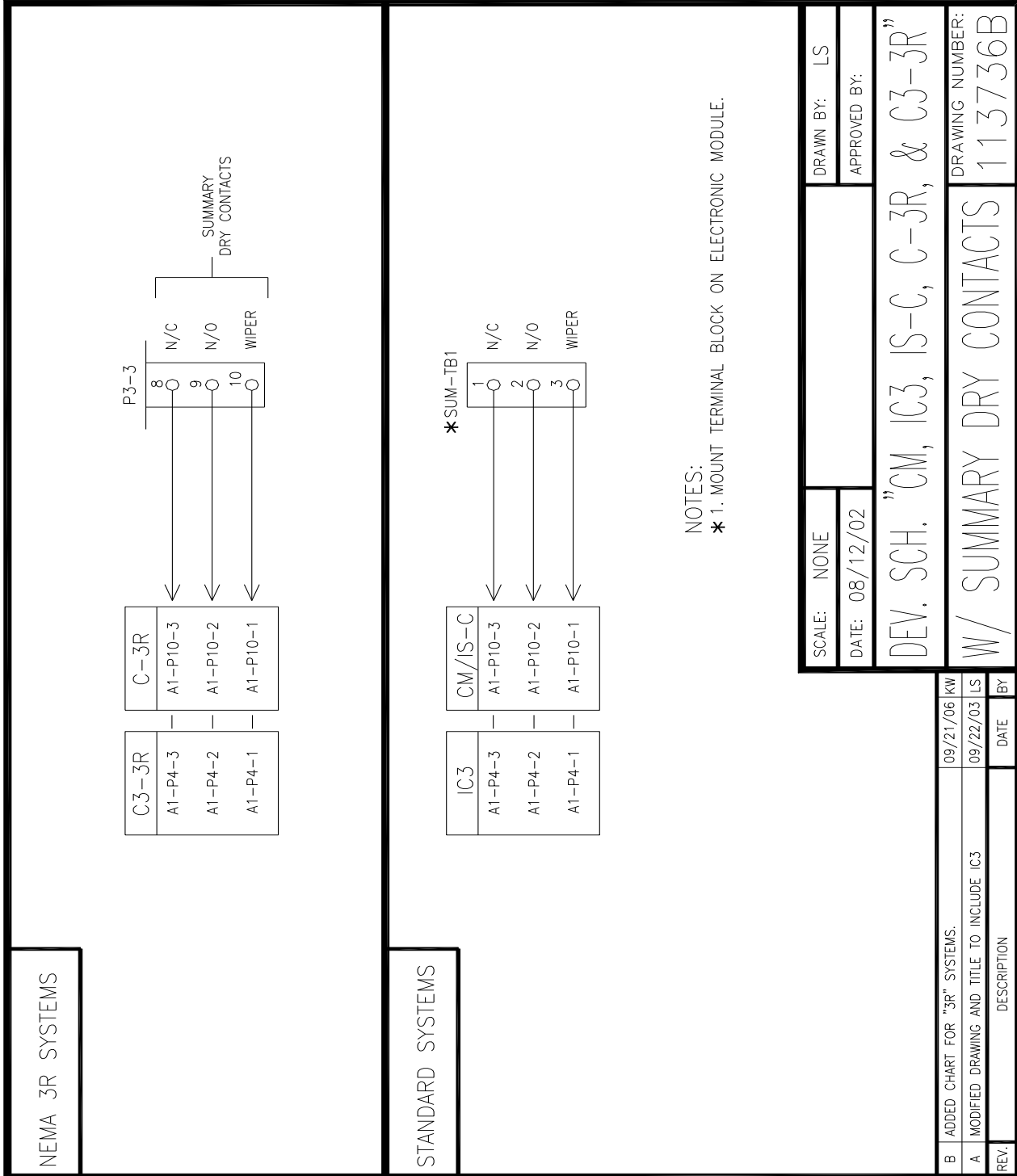

# REMOTE SUMMARY ALARM PANEL SCHEMATIC

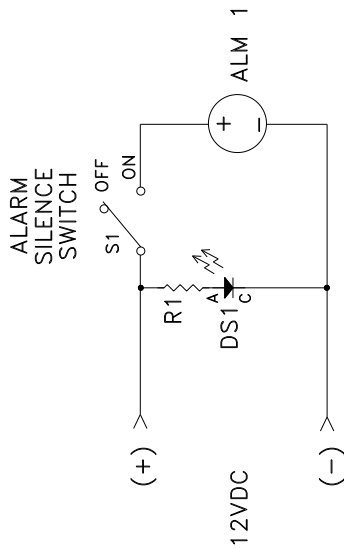
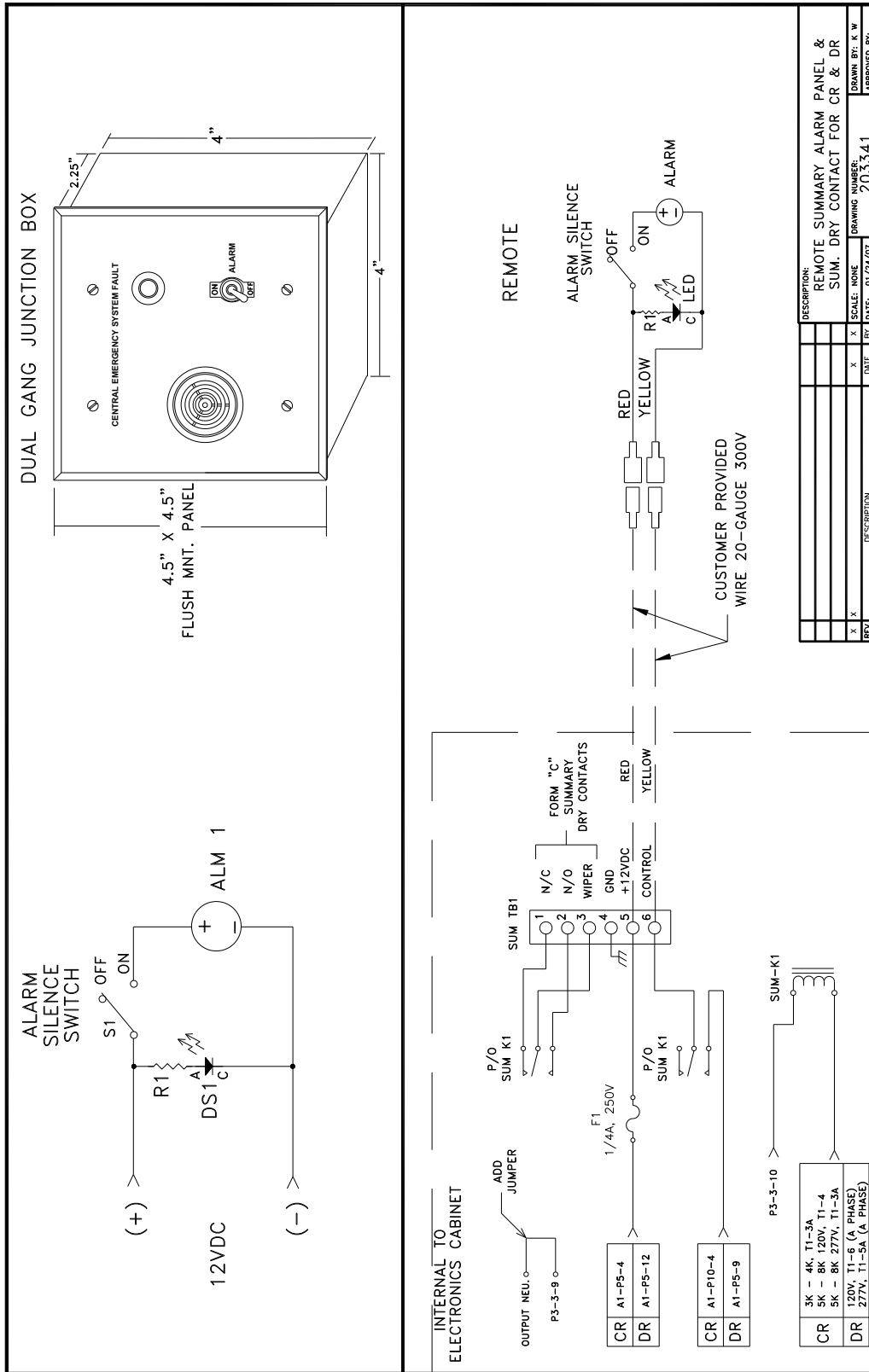

INTERNAL TO ELECTRONICS CABINET

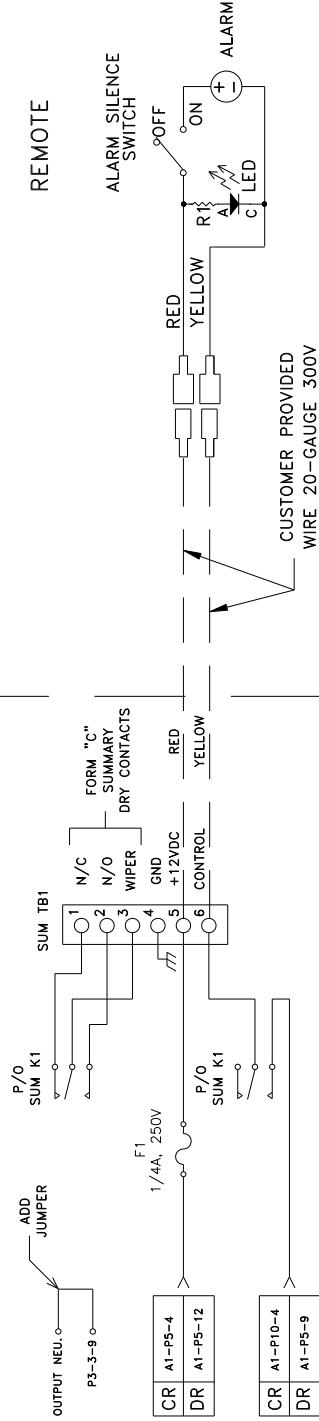

|    |                       |
|----|-----------------------|
| CR | 3K - 4K, T1-5A        |
| CR | 5K - 8K 120V, T1-4    |
| CR | 5K - 8K 277V, T1-5A   |
| DR | 120V, T1-6 (A PHASE)  |
| DR | 277V, T1-5A (A PHASE) |

| REV | DATE | BY | DESCRIPTION |
|-----|------|----|-------------|
| X   | X    | X  | X           |
| X   | X    | X  | X           |
| X   | X    | X  | X           |

DESCRIPTION: REMOTE SUMMARY ALARM PANEL & SUM. DRY CONTACT FOR CR & DR

SCALE: NONE

DRAWING NUMBER: 203341

DATE: 01/24/07

BY: K W

APPROVED BY:

# REMOTE METER PANEL SCHEMATIC

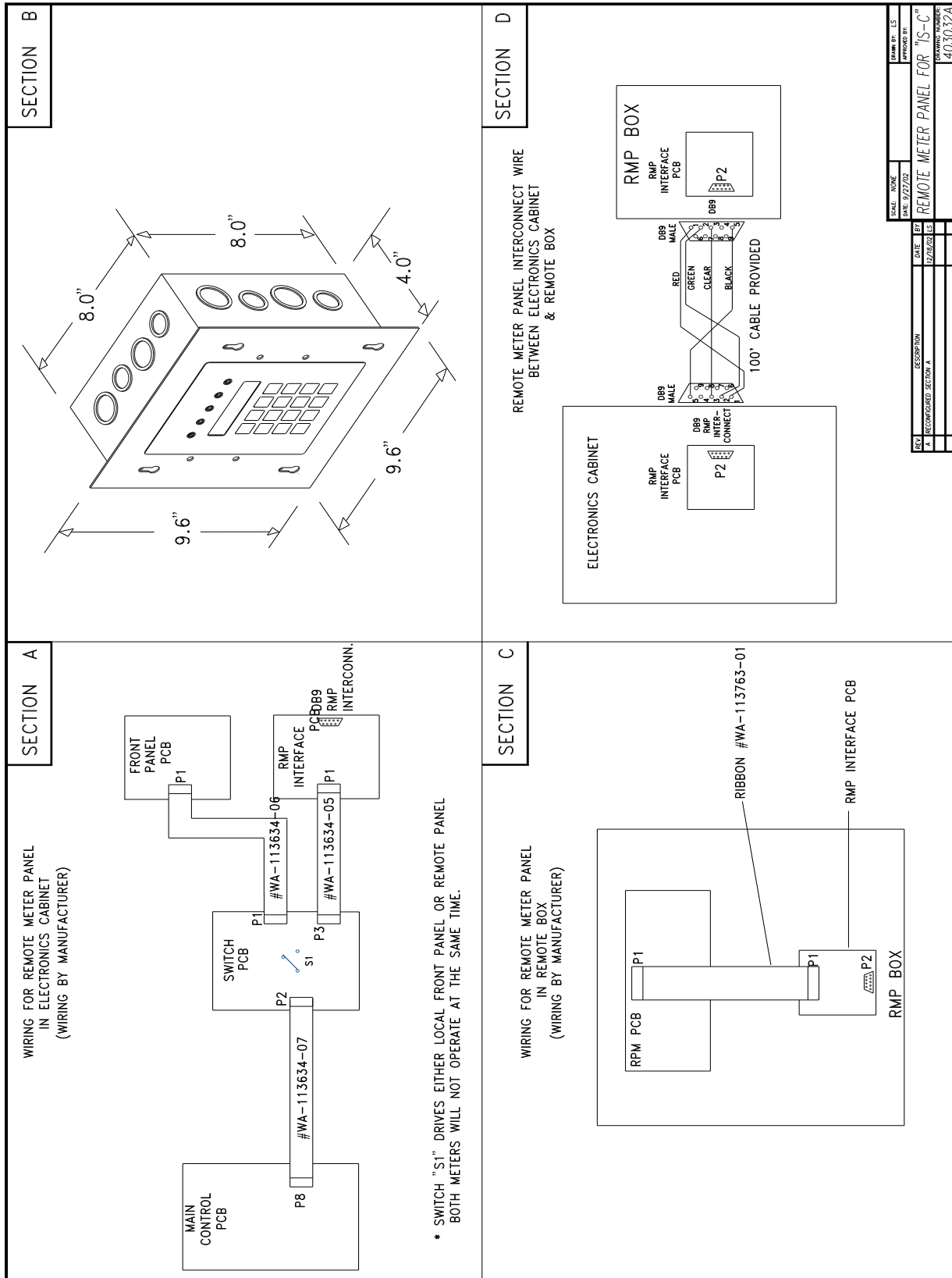

## SECTION 10

# RS232 OPERATION

### 1.0 INTRODUCTION:

This section is intended to explain the operation and communication protocol for the Emergency Lighting Central Inverter. Serial Communication can be established by means of a computer using Hyper-Link windows based software or using a Terminal device.

### 2.0 CONNECTION:

The Central Inverter has a 9-pin Sub-D Female connector located inside the inverter. See Fig. 10.2 or Fig. 10.3 for the exact location of the connector.

The Connector between the computer and the Inverter is a straight connection. Do not use a Null Modem Cable that flips pins 2 and 3. Pin 2 and Pin 3 are the Data send and receive lines; Pin 5 is the Ground.

Optical isolation on the Interface card provides galvanic isolation between the computers ground and the Inverters ground.

#### PC Connector DB-9 Central Inverter

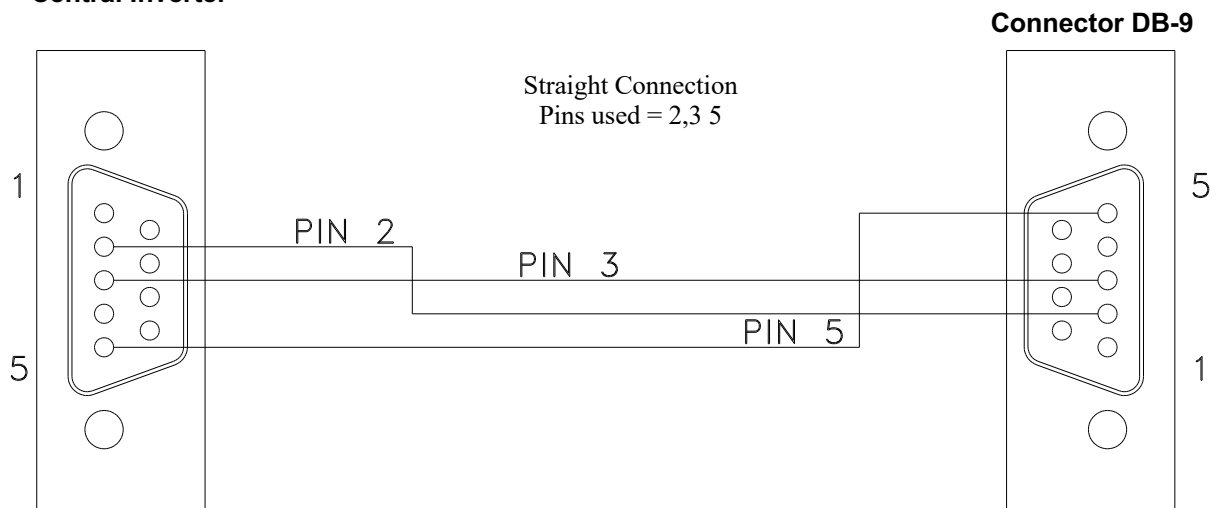

Fig. 10.1 – Interconnect Schematic for RS-232 Connection

Communication is established through a standard ASCII format of 8 Data bits, 1 Stop bit, No parity, No Flow Control, and a Baud rate of 9600 BPS.

### 3.0      **PROTOCOL:**

The Protocol is the command architecture between the PC and the Central Inverter System. Information is exchanged between the two devices under this architecture.

The PC is the initiator of the communication. It sends out a command all in upper case letters like the following string.

**\*ACC[DDDD]S<CR>**

\*:                   Start Character, marks the start of a command.  
A:                   Character represents the System's node address range 0 – F.  
                      0 to E is for address specific and F is for all nodes.  
CC:                  Two characters for command.  
DDDD:               Data Field with variable length.  
S:                   Character for check sum hex representation.  
<CR>:               Enter Key or character 0x0d.

When the System receives this string of characters, it must reply back. The System sends out all information back to the PC in lower case letters.  
The System would respond to the above string in the following.

**\*acc[dddd]s<CR>**

\*:                   Start Character, marks the start of a command.  
a:                   Character represents the System's node address range 0 – E.  
cc:                  Two characters for command.  
dddd:               Data Field with variable length.  
s:                   Character for check sum hex representation.  
<CR>:               Enter Key or character 0x0d.



## 4.0 COMMANDS

### Meter Functions

#### 4.1 Get Alarm Status

PC Interface: \*0AS0<CR>  
System Interface: \*0asdddd0<CR>

Where dddd represents 16-bit status in HEX format.

Please refer to the Alarm Summary Table for detail definitions.

#### **Alarm Summary Table**

| <b>Bit</b> | <b>Description</b>      |
|------------|-------------------------|
| 0          | Overload Alarm          |
| 1          | Overload Shutdown Alarm |
| 2          | High AC Voltage Alarm   |
| 3          | Low AC Voltage Alarm    |
| 4          | High Ambient Alarm      |
| 5          | Circuit Breaker Alarm   |
| 6          | Load Variation Alarm    |
| 7          | Near Low Battery Alarm  |
| 8          | Low Battery Alarm       |
| 9          | Inverter Failure Alarm  |
| 10         | Charge Failure Alarm    |
| 11         | Utility Failure Alarm   |
| 12         | Fan Failure Alarm       |
| 13         | Output Fault Alarm      |
| 14         | Spare                   |
| 15         | Spare                   |

The Alarm status is in Hex format. Since there are 16 different alarms (0-15) the individual alarms can be one bit. The conversion from hex to binary is as follows:

| <b>Hex</b> | <b>Binary</b> |
|------------|---------------|
| 0          | 0000          |
| 1          | 0001          |
| 2          | 0010          |
| 3          | 0011          |
| 4          | 0100          |
| 5          | 0101          |
| 6          | 0110          |
| 7          | 0111          |
| 8          | 1000          |
| 9          | 1001          |
| A          | 1010          |
| B          | 1011          |
| C          | 1100          |
| D          | 1101          |
| E          | 1110          |
| F          | 1111          |

**If there were an overload alarm, the Alarm status would read 0001 in hex, which would be 0000000000000001 in binary. As can be seen, the last bit (bit 0) is set, indicating an overload alarm.**

## 4.2 Get Indicator Status

PC Interface: \*0IS0<CR>  
System Interface: \*0isdd0<CR>

Where dd represents 8 bit data in HEX format

Please refer to Indicator Status Table for definitions

### Indicator Status Table

| Bit | Description                             |
|-----|---|
| 0   | System Ready                            |
| 1   | AC Present                              |
| 2   | Battery Charging                        |
| 3   | Battery Power                           |
| 4   | Spare                                   |
| 5   | Spare                                   |
| 6   | Spare                                   |
| 7   | Phase (0 is single phase, 1 is 3 phase) |

This format is just like the Alarm status. Please read Hex format from Alarm Status.

## 4.3 Get Input Voltage

PC Interface: \*0VI $\phi$ 0<CR>  
System Interface: \*0vidddd0<CR>

Where dddd represents the value in decimal format (1200 means 120.0)  
 $\phi$  is the phase number = 1,2,3 for A,B,C.

## 4.4 Get Output Voltage

PC Interface: \*0VO $\phi$ 0<CR>  
System Interface: \*0vodddd0<CR>

Where dddd represents the value in decimal format (1200 means 120.0)  
 $\phi$  is the phase number = 1,2,3 for A,B,C.

## 4.5 Get Output Current

PC Interface: \*0IO $\phi$ 0<CR>  
System Interface: \*0iodddd0<CR>

Where dddd represents the value in decimal format (1200 means 120.0)  
 $\phi$  is the phase number = 1,2,3 for A,B,C.

## 4.6 Get Battery Voltage

PC Interface: \*0BV0<CR>  
System Interface: \*0bvddd0<CR>

Where dddd represents the value in decimal format (1200 means 120.0)

#### 4.7 **Get Battery Current**

PC Interface: \*0B0I<CR>  
System Interface: \*0bidddd0<CR>

Where dddd represents the value in decimal format (1200 means 120.0)

#### 4.8 **Get Ambient Temperature**

PC Interface: \*0TP0<CR>  
System Interface: \*0tpdddd0<CR>

Where dddd represents the value in decimal format (1200 means 120.0).

#### 4.9 **Get Output Watts**

PC Interface: \*0WA0<CR>  
System Interface: \*0wadddd0<CR>

Where dddd represents the value in decimal format (1200 means 120.0).

#### 4.10 **Get Output VA**

PC Interface: \*0VA $\phi$ 0<CR>  
System Interface: \*0vadddd0<CR>

$\phi$  is the phase number = 1,2,3 for A,B,C.

Where dddd represents the value in decimal format (1200 means 120.0).

#### 4.11 **Get Elapsed run time (days)**

PC Interface: \*0ED0<CR>  
System Interface: \*0etdddd0<CR>

Where dddd represents the value in decimal format (100 means 100).  
Time is in hours.

#### 4.12 **Get Inverter Run time**

PC Interface: \*0RT0<CR>  
System Interface: \*0rtdddd0<CR>

Where dddd represents the value in decimal format (100 means 100).  
Time is in minutes.

## 5.0 CONTROL FUNCTIONS

### 5.1 Set Date

PC Interface: \*0DAMMDDYYYY0<CR>  
System Interface: \*0dae0<CR>

MM is month, DD is day, YYYY is year.  
e is one character error code.

### 5.2 Get Date

PC Interface: \*0DA0<CR>  
System Interface: \*0dammdyyy0<CR>

### 5.3 Set Time

PC Interface: \*0TMHHMMSS0<CR>  
System Interface: \*0tme0<CR>

HH is hours, MM are minutes, SS is seconds. Time is based on the 24-Hour Standard.  
e is one character error code.

### 5.4 Get Time

PC Interface: \*0TM0<CR>  
System Interface: \*0tmhmmss0<CR>

### 5.5 Set Inverter Max Run Time

PC Interface: \*0MTHHHHHH0<CR>  
System Interface: \*0mte0<CR>

HHHHHH is hours in decimal format (100 means 100)  
e is one character error code.

### 5.6 Get Inverter Max Run Time

PC Interface: \*0MT0<CR>  
System Interface: \*0mthhhhhe0<CR>

### 5.7 Set Output Current Load Reduction Fault

PC Interface: \*0LF $\phi$ DDDD0<CR>  
System Interface: \*0lfe0<CR>

DDDD: 4 characters represent amps, in decimal format (100 means 10.0)  
Where  $\phi$  is the phase letter = A,B,C.  
e: error code

## 5.8 Get Output Current Load Reduction Fault

PC Interface: \*OLF $\phi$ 0<CR>  
System Interface: \*0lfdddd0<CR>

$\phi$  is the phase letter = A,B,C.

## 5.9 Set Low Battery Voltage Alarm

PC Interface: \*0LBDDDD0<CR>  
System Interface: \*0lbe0<CR>

DDDD: 4 characters represent Volts, in decimal format (100 means 10.0)  
e: error code

## 5.10 Get Low Battery Voltage Alarm

PC Interface: \*0LB0<CR>  
System Interface: \*0lbdddd0<CR>

## 5.11 Set Low AC Voltage Alarm

PC Interface: \*0LVDDDD0<CR>  
System Interface: \*0lve0<CR>

DDDD: 4 characters represent Volts, in decimal format (100 means 10.0)  
e: error code

## 5.12 Get Low AC Voltage Alarm

PC Interface: \*0LV0<CR>  
System Interface: \*0lvdddd0<CR>

## 5.13 Set High AC Voltage Alarm

PC Interface: \*0HVDDDD0<CR>  
System Interface: \*0hve0<CR>

DDDD: 4 characters represent Volts, in decimal format (100 means 10.0)  
e: error code

## 5.14 Get High AC Voltage Alarm

PC Interface: \*0HV0<CR>  
System Interface: \*0hvdddd0<CR>

## 5.15 Set Ambient Temperature Alarm

PC Interface: \*0ATDDDD0<CR>  
System Interface: \*0ate0<CR>

DDDD: 4 characters represent degrees, in decimal format (100 means 10.0)  
e: error code  
Data is in degrees centigrade.

## 5.16 Get Ambient Temperature Alarm

PC Interface: \*0AT0<CR>  
System Interface: \*0atddd0<CR>

## 5.17 Get Test Log

PC Interface: \*0LTijj0<CR>  
System Interface: \*0ltddd0<CR>

ddd is a character string containing the event number, field number and field data.

ii is a decimal number between 0 and 75 that represents the Event number.

j is a decimal number between 0 and 6 that represents the Field in the event.

Field 0= Date (mm/dd/yy)  
Field 1= Time (hh:mm)  
Field 2 = Duration (mmmm)  
Field 3 = Voltage Output  
Field 4 = Current Output  
Field 5 = Load Reduction Fault (LRF: Yes/No)  
Field 6 = Event or Month Test or Year Test

## 5.18 Dump Test Log

PC Interface: \*0DT0<CR>  
Command for dumping all Tests to the RS-232 port.

## 5.19 Get Event Log

PC Interface: \*0LEijj0<CR>  
System Interface: \*0leddd0<CR>

ddd is a character string containing the event number, field number and field data.

ii is a decimal number between 0 and 19 that represents the Event number.

j is a decimal number between 0 and 6 that represents the Field in the event.

Field 0= Date (mm/dd/yy)  
Field 1= Time (hh:mm)  
Field 2 = Duration (mmmm)  
Field 3 = Voltage Output  
Field 4 = Current Output  
Field 5 = Load Reduction Fault (LRF: Yes/No)  
Field 6 = Event or Month Test or Year Test

## 5.20 Dump Event Log

PC Interface: \*0DE0<CR>  
Command for dumping all Events to the RS-232 port.

### 5.21 Get Alarm Log

PC Interface: \*0LEijj0<CR>  
System Interface: \*0leddd0<CR>

ddd is a character string containing the event number, field number and field data.

ii is a decimal number between 0 and 19 that represents the Event number.  
j is a decimal number between 0 and 6 that represents the Field in the event.

Field 0 = Date (mm/dd/yy)  
Field 1 = Time (hh:mm)  
Field 2 = Alarm Type

### 5.22 Dump Alarm Log

PC Interface: \*0DF0<CR>  
Command for dumping all Logs to the RS-232 port.

### 5.23 Initiate Test

PC Interface: \*0TS0<CR>

## 6.0 HYPER TERMINAL SETUP

Hyper Terminal is available with Windows through the Program Menu, Accessories Menu, and Communications Menu.

For most computers, the setup should be for a local connection through COM1.  
The Local connection should be set to:

Bits Per Second: 9600  
Data Bits: 8  
Parity: None  
Stop Bits: One  
Flow Control: None

After the Local connection is established, the easiest way to communicate is through the Transfer Menu, Send Text File.

A File can be written in Notepad and saved as a text file. While Hyper Terminal is running this file can be transferred using the Send Text File located under the Transfer Menu.

#### Example:

Text File - \*0DF0<CR>

When this text file is sent out the System will "Dump" all alarms back.

## **7.0 CONFIGURING THE ZOOM MODEM**

### **7.1 Connect the 9VDC Power Adapter**

### **7.2 Connect the PC serial port to the modem's serial port**

### **7.3 On the PC, bring up a terminal communications program such as HyperTerminal.**

### **7.4 Configure HyperTerminal to the following:**

9600 BPS  
8 Data Bits  
No Parity  
No Stop Bits  
No Flow Control

### **7.5 Make sure there is communication by typing AT<enter> until the message "OK" appears.**

### **7.6 Type the following AT commands:**

ATM1 <enter> (speaker on until connected)  
AT&D0 <enter> (ignore DTR)  
AT&K0 <enter> (no flow control)  
ATS0=1 <enter> (auto-answer after one ring)  
AT&W0 (store to non-volatile memory)

## **8.0 DIALING THE ZOOM MODEM**

### **8.1 Type AT<enter> until the message "OK" appears**

### **8.2 Type for example:**

ATD9, 16109545224 <enter>  
ATD is the command  
9,16109545224 is the phone number –9, for outside line.

### **8.4 Wait for the message "connected"**

### **8.5 To hang up:**

Type three plus signs (+++) and wait for the message "OK"  
Type ATH0 <enter> to hang up or,  
Type ATO0 <enter> to enter online mode again



**LOCATION OF THE RS232 PORT**

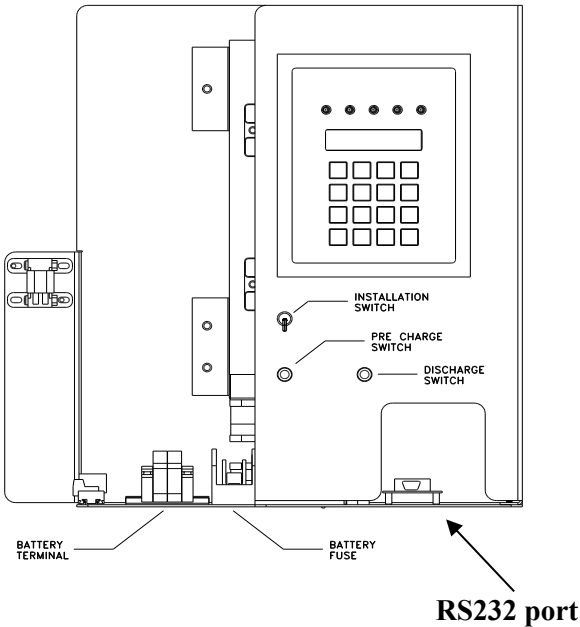

**Fig. 10.2**

# DETAILED WIRING DIAGRAM

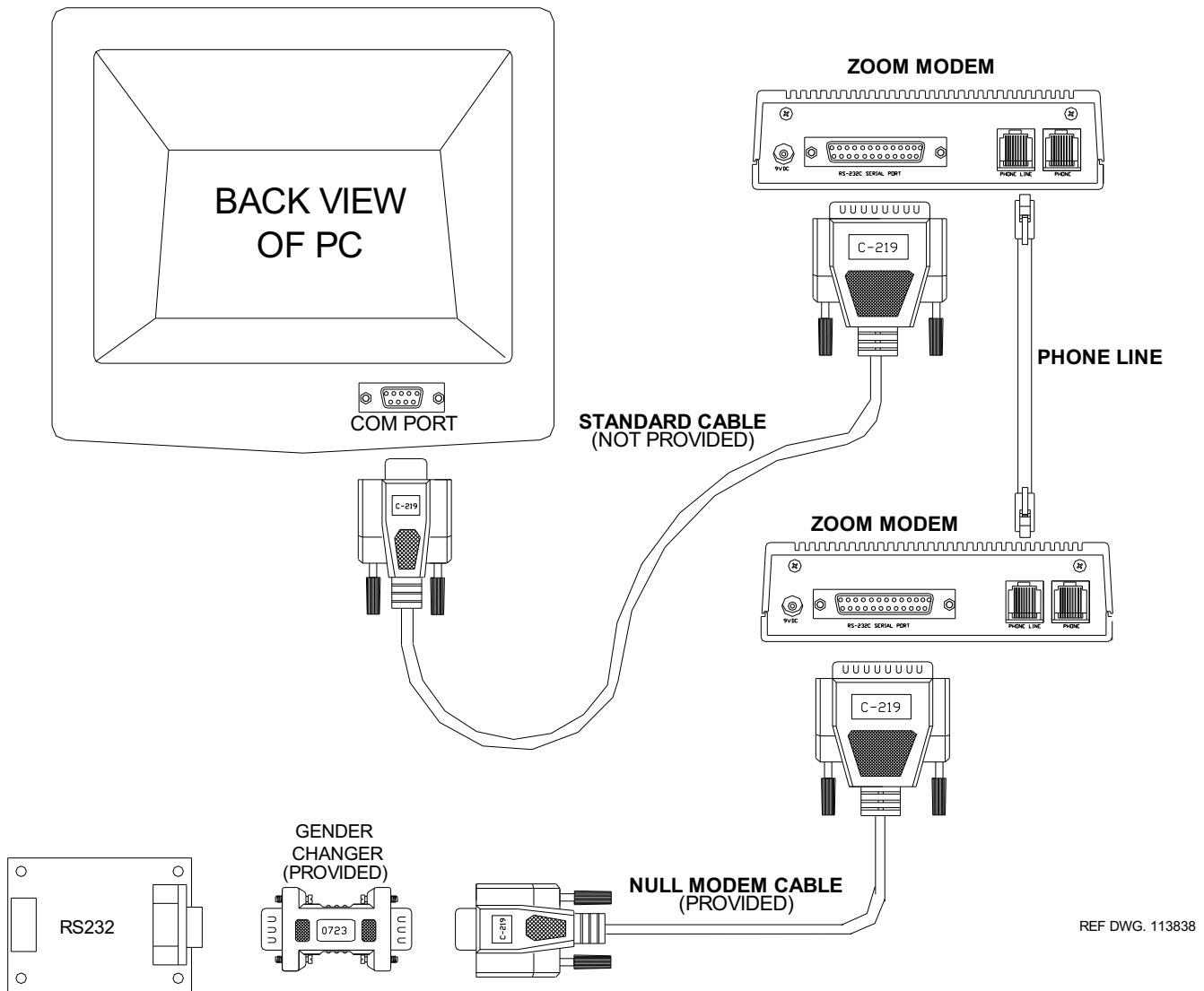

Fig. 10.4

# ZOOM MODEM CONNECTION BLOCK DIAGRAM

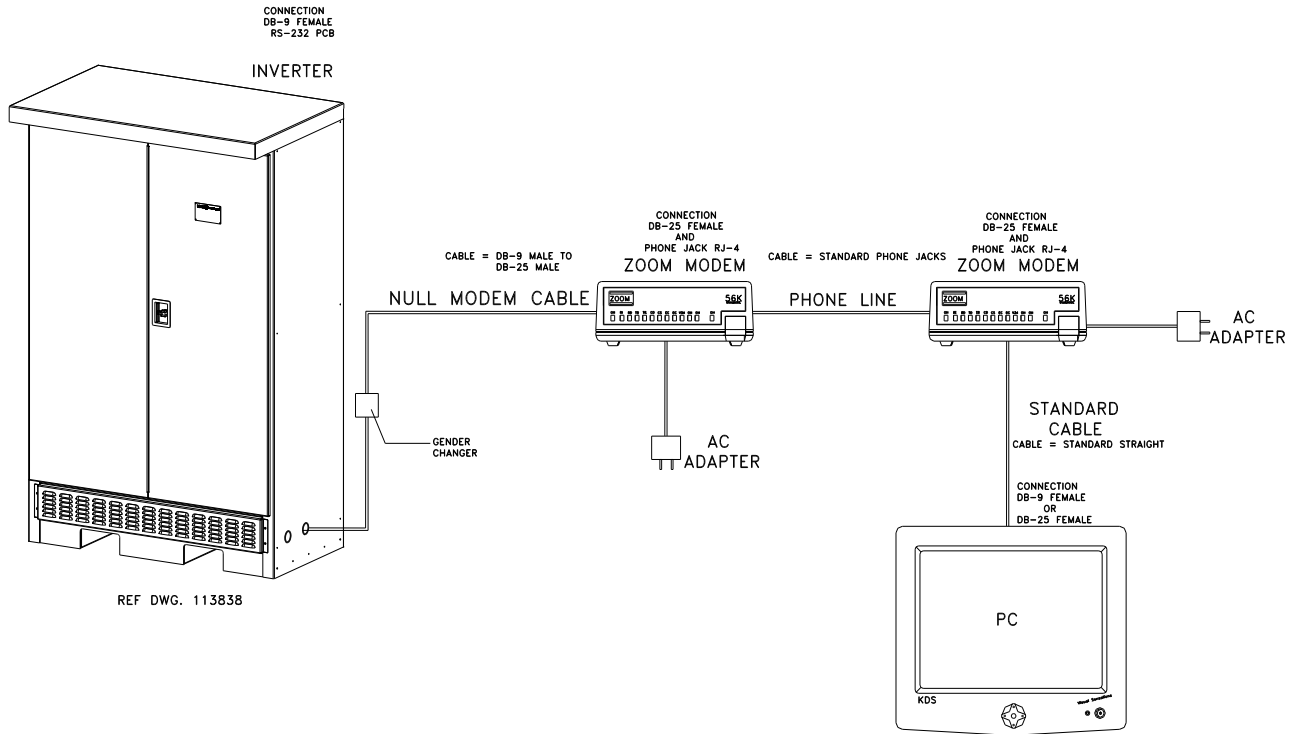

Fig. 10.5

## **Completing the Installation**

Replace the dead front panels, close the doors and lock the cabinet. You have finished installing the system.

Keep the System Installation / User Guide in the folder attached to the inside of the system door.

### **Notes:**

# SECTION 11

## SPECIFICATIONS

### General Specifications

|                              |   |   |
|------------------------------|---|---|
| <b>Input</b>                 | Voltage   | 120 or 277Vac 1-phase 2-wire; 120/208 or 277/480Vac 3-phase 4-wire +10% -15%. Contact factory for other voltages  |
|                              | Power Walk-in Frequency                                       | Walk-in limiting inrush current to less than 125%, 10 times for 1 line cycle<br>60Hz +/- 3%   |
|                              | Synchronizing Slew Rate                                       | 1Hz per second nominal  |
|                              | Protection  | Input Circuit Breaker   |
|                              | Harmonic Distortion   | < 10%   |
|                              | Power Factor  | .5 lag/lead   |
| <b>Output</b>                | Voltage   | 120 or 277Vac 1-phase 2-wire; 120/208 or 277/480Vac 3-phase 4-wire +10% -15% Contact factory for other voltages.  |
|                              | Static Voltage  | Load current change +/-2%, battery discharge +/-12.5%   |
|                              | Dynamic Voltage   | +/- 2% for +/-25% load step change, +/-3% for a 50% load step change, recovery within 3 cycles  |
|                              | Harmonic Distortion   | < 3% THD for linear load  |
|                              | Overload  | Fuse protected  |
|                              | Frequency   | 60Hz +/- .05Hz during emergency mode  |
|                              | Load Power Factor   | .5 lag to .5 lead   |
| Inverter Overload Protection |   | 115% for 10 minutes      Overload: 115% for 5 minutes; 125% for 12 line cycles.   |
|                              |   | Optional Main Circuit Breaker   |
| <b>Battery</b>               | Type  | Front access valve-regulated sealed lead-calcium.   |
|                              | Charger   | Microprocessor controlled and temperature compensating (recharge per UL924 specification)   |
|                              | Protection  | Automatic low-battery disconnect; automatic restart upon utility return.  |
|                              | Disconnect  | Fuse  |
|                              | Transport   | Built-in handles.   |
| <b>Environmental</b>         | Altitude  | < 10,000 feet (above sea level) without derating  |
|                              | Operating Temperature   | 32 to 104 degrees F (0 to 40 degrees C) Optional; -4 to 104 degrees F (-20 to 40 degrees C)   |
|                              | Storage Temperature   | -4 to 158 degrees Fahrenheit (-20 to 70 degrees Celsius) (electronics only)   |
|                              | Relative Humidity   | < 95% (non-condensing)  |
| <b>General</b>               | Design  | Standby no break. PWM inverter type utilizing IGBT technology with 2mS transfer time.   |
|                              | Generator Input   | Compatible with generators.   |
|                              | Control Panel   | Microprocessor controlled 2 x 20-character LCD display with touch pad controls/functions, 5 LED indicators & alarm status indicator.  |
|                              | Metering  | Input & Output Voltage, Battery Voltage, Battery & Output Current, Output VA, Temperature, Inverter Wattage   |
|                              | Alarms  | High/Low Battery Charger Fault, Near Low Battery, Low Battery, Load Reduction Fault, Output Overload, High/Low AC Input Volts, High Ambient Temperature, Inverter Fault, Output Fault, Optional Circuit Breaker Trip              |
|                              | Communications  | RS-232 port (DB9)   |
|                              | Manual Maintenance Bypass                                     | Internal (standard)   |
|                              | Alarm Contacts  | Summary Form "C" Contacts (standard)  |
|                              | Warranty  | 1 year standard warranty includes all parts, labor, & travel expenses within 48 contiguous states. Up to 10 years pro-rated warranty on batteries available. Preventative maintenance and customized service plans are available. |
|                              | Factory Start-up  | Purchase factory start-up & receive 1 additional year of warranty.  |
| 5-Year Service Plan          | Purchase 5-year service plan & receive free factory start-up. |   |
| <b>Physical</b>              | Cabinet   | NEMA type 3R, freestanding, two-door, powder coat CRS standard; stainless steel enclosure optional.   |
|                              | Cooling   | Forced Air. Temperature controlled fans.  |
|                              | Cable Entry   | Sides and bottom  |
|                              | Access  | Front ONLY  |
|                              | Seismic Zone 4  | Optional; Floor mounting brackets add 2" to each side (52"W total)  |
|                              | Locking Device  | 3-Point locking latch with Corbin 60 lock   |

## SECTION 12

# MAINTENANCE AND SERVICE

The Self-testing feature of the inverter ensures that the system is tested at least once per month for 5 minutes and once per year for 90 minutes. If there are any problems with the self-tests, the fault log shall indicate which faults occurred. Please see the fault descriptions and troubleshooting guide.

A few simple maintenance operations performed periodically will help ensure many years of trouble free operation. Battery terminals should be checked for tightness and corrosion. If severe corrosion is evident, maintenance is required to correct this situation.

Since the unit depends on unrestricted airflow for cooling of power handling components, it is important to keep the air vents free of any obstruction. If the environment tends to be extremely dusty, occasionally blow away any accumulation of dust on components. Please follow the shutdown procedure before cleaning.

**CAUTION:** Follow the shutdown procedure (See Section 6) before cleaning. An authorized technician only should perform Service!

**Table 12.1 Preventive Maintenance Schedule**

| SERVICE TO PERFORM:  | PERFORM SERVICE EVERY: |          |           |
|--|------------------------|----------|-----------|
|  | 3 MONTHS               | 6 MONTHS | 12 MONTHS |
| <b>1. TEST UNIT:</b><br><br><b>NOTE:</b> Perform manual test only when critical load is connected but not required.<br>----- Output voltage should be present.<br>----- Confirm operations of front panel indicators.    | X                      |          |           |
|  |                        |          |           |
|  |                        |          |           |
|  |                        |          |           |
|  |                        |          |           |
|  |                        |          |           |
|  |                        |          |           |
| <b>2. INSPECT BATTERIES:</b><br><br>----- All connections are tight.<br>----- Connections have no corrosion. (Clean if necessary).   |                        | X        |           |
|  |                        |          |           |
|  |                        |          |           |
|  |                        |          |           |
|  |                        |          |           |
|  |                        |          |           |
|  |                        |          |           |
| <b>CLEAN UNIT:</b> NOTE: Unit must be shut down during this service.<br>----- Inspect air vents and clean if necessary.<br>----- Clean excessive dust from inside cabinet(s).<br>----- Clean excessive dust from fan(s). |                        |          | X         |
|  |                        |          |           |
|  |                        |          |           |
|  |                        |          |           |
|  |                        |          |           |
|  |                        |          |           |
|  |                        |          |           |

"X" Indicates when to perform service. Lines below the "X" are for the date of service.

# TROUBLE SHOOTING CHART

| THE NUMBER IN THE CHART INDICATES ORDER IN WHICH PROBLEMS SHOULD BE CHECKED | S<br>Y<br>M<br>P<br>T<br>O<br>M<br>S | Inverter will not run during a power failure | System draws excessive AC input current | System noisy, excessive hum during normal run conditions | AC output voltage low during utility power failure | System overheats, smells, smokes, etc. | System noisy, transformer hum during power failure | Inverter jitters or staggers during a power failure | System blows battery fuse (& fuses in battery cabinet if applicable) | Charger not charging properly, low or dead | Charger stays in HI charge | Batteries require continuous addition of water to keep proper level (optional w/ wet cells) | Battery acid leaking in cabinet or around tops of batteries | Battery voltage does not read properly after installation of fresh cells | Battery Voltage low or non-existent |
|---|--------------------------------------|--|---|--|--|--|--|---|--|--|----------------------------|---|---|--|-------------------------------------|
|   |                                      |  |   |  |  |  |  |   |  |  |                            |   |   |  |                                     |
|   |                                      | 1  |   |  |  |  |  |   |  |  |                            |   |   |  |                                     |
| Installation switch on inverter in off position                             |                                      |  |   |  |  |  |  |   |  |  |                            |   |   |  |                                     |
| Shorted IGBT module(s)  |                                      | 3  |   |  | 3  |  |  | 1   | 3  |  |                            |   |   |  |                                     |
| No AC input voltage   |                                      |  |   |  |  |  |  |   |  | 2  |                            |   |   |  |                                     |
| Defective inverter  |                                      | 4  |   |  |  | 2                                      | 1  | 3   | 5  |  |                            |   |   |  |                                     |
| Output volt-ampere rating of unit being exceeded                            |                                      | 6  | 1                                       |  | 1  | 2                                      | 2  | 2   | 6  |  |                            |   |   |  |                                     |
| Ambient temperature too high, vents blocked                                 |                                      |  |   |  |  |  |  |   |  |  |                            | 3   | 1   |  |                                     |
| Shorted load  |                                      |  | 2                                       |  | 4  |  | 3  |   |  |  |                            |   |   |  |                                     |
| Reverse battery diodes shorted  |                                      |  |   |  |  |  |  |   | 2  |  |                            |   |   |  |                                     |
| Open battery fuse (& fuses in battery cabinet if applicable)                |                                      | 2  |   |  |  |  |  |   |  |  |                            |   |   |  | 1                                   |
| Battery polarity wrong  |                                      |  |   |  |  |  |  |   |  |  |                            |   |   |  |                                     |
| Defective charger   |                                      | 11   |   | 1  |  | 4                                      |  |   |  | 6  | 1                          | 1   | 2   | 4  | 2                                   |
| Battery capacity low  |                                      | 7  |   |  |  |  |  |   |  |  |                            |   |   | 3  | 3                                   |
| Low water in battery (optional w/ wet cells)                                |                                      | 10   |   |  |  |  |  |   |  |  |                            |   |   |  | 4                                   |
| Wrong amount of battery cells in series                                     |                                      | 9  |   | 2  |  | 6                                      |  |   | 4  | 4  | 2                          | 2   | 4   | 1  | 5                                   |
| Batteries dead, low or defective  |                                      | 8  |   |  |  |  |  |   |  | 5  | 3                          | 4   | 3   | 2  |                                     |
| Transfer module and/or control circuit malfunction                          |                                      | 5  |   |  |  |  |  |   |  |  |                            |   |   |  |                                     |
| Transformer not connected for proper voltage                                |                                      |  | 3                                       | 3  |  | 5                                      |  |   |  |  |                            |   |   |  |                                     |

## SECTION 13

# HEATER OPTION INSTALLATION AND OPERATION

### Heater Option Installation:

**CAUTION SHOULD BE USED WHEN INSTALLING THE BATTERIES TO PREVENT DAMAGE TO THE HEATING ELEMENTS LOCATED ON THE SHELF BENEATH THE BATTERIES.**

Remove the battery bracket located on each shelf before installing batteries. This bracket is used to secure the batteries once they are installed on each shelf.

**A separate utility feed is required for the heater option.**

The input power requirement is approximately 1,400 Watts. The power factor will be unity since the heater option consists of resistive heating elements.

The following table is a matrix for most utility feed requirements. Your machine will be clearly labeled with its input voltage requirements – check your print package provided with your machine.

| <b><u>Input Voltage</u></b> | <b><u>Input Current</u></b> |
|-----------------------------|-----------------------------|
| 120 VAC                     | 12 Amps                     |
| 208 VAC                     | 7 Amps                      |
| 240 VAC                     | 6 Amps                      |
| 277 VAC                     | 5 Amps                      |
| 480 VAC                     | 3 Amps                      |



## Heater Option Operation:

The Heater option contains all the required components to maintain the batteries at a constant temperature of 25 deg. C or 77 deg. F. It comes pre-wired and programmed and should require no operator interface.

To turn the heater option on, simply turn on it's dedicated circuit breaker located on the lower shelf containing all the AC circuit distribution.

The Heater Option consists of a Temperature Controller, Solid State Switch, Temperature Sensor, and Heating Elements.

The Temperature Controller is located in the upper left corner of the electronic shelf and its default display is the current temperature and programmed temperature. The programmed temperature is factory set to 25 deg. C or 77 deg. F.

The Solid State Switch is located directly below the Controller and its function is to connect and disconnect power to the heating elements. The Solid State Switch is fed from a 120 VAC source. If your input power is not 120 VAC, there is a factory provided Isolation Transformer to provide the 120 VAC to the Solid State Switch.

The Temperature Sensor is an RTD type and is located in the cable bundle on the left side of the middle battery shelf.

There is one heating element of 450 Watts for each battery shelf. Each element spreads heat beneath the batteries. This even distribution eliminates hot spots and uneven heat distribution between the batteries.

**The Temperature Controller is factory programmed and should only be changed by authorized factory personnel.**

## SECTION 14

# ANCHOR BOLT PLACEMENT

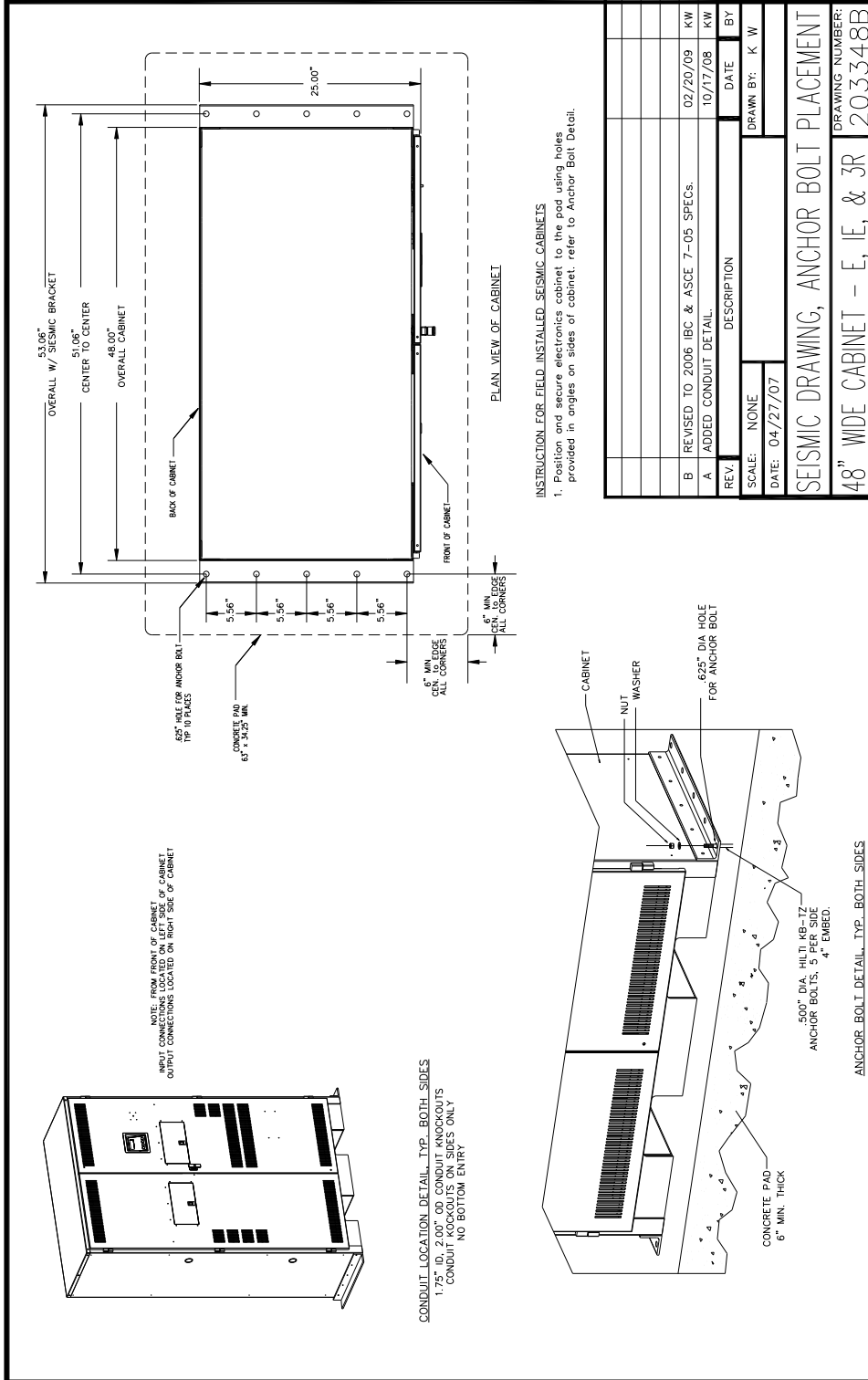

## SECTION 15

# WARRANTY

### **RETURN MATERIAL AUTHORIZATION (RMA) POLICY**

No return material is accepted without written "Return Material Authorization"(RMA). An RMA number is obtainable by contacting the Field Service Department.

Every effort will be made to correct problems over the phone before a RMA is granted or a service trip made. Cooperation will save both time and expense for customer and manufacturer.

If it is deemed necessary to return material, the RMA number must appear on shipping labels, packing slips, and bills of lading.

### **OUT OF WARRANTY REPAIR CHARGES AND LABOR**

Contact Field service for current parts and labor rates. A minimum rate will be assessed. The manufacturer will not proceed with repairs of an out of warranty unit until authorization in the form of a purchase order is received from the customer. The unit for repair must be returned prepaid with an RMA number on the carton. For travel to the job site, a quote "Not to Exceed" estimate will be given. A purchase order to cover that amount is required before a trip to the job site is made.

## LIMITED WARRANTY

The parts and on-site labor for the electronics portion of this equipment are warranted against defects in workmanship and material for a period of one year from time of shipment, but in no case will this warranty be valid if installation of equipment is not accomplished within 180 days from date of shipment. Batteries cannot be disconnected from the unit for long periods (180 days) or they will not be able to charge, creating malfunction of both batteries and/or electronics and thereby voiding the warranty. Systems ordered with "Heavy Lead" batteries over 25 Ah have a one year unconditional battery warranty with an additional prorated warranty contingent upon timely return of warranty registration card and the terms called out in the particular battery warranty sheet. See individual battery warranty policy.

The warranty does not cover damage caused by abuse, improper environmental conditions, shipping damage, improper electronics and/or battery installation, unauthorized modifications, service by unauthorized personnel, transportation of damaged equipment, or acts of war. Damage due to lack of maintenance (where applicable) or damage resulting from installation in areas with other than normal temperatures are not covered. See the battery warranty policy for details, as adverse environmental conditions reduce battery life and void the warranty. Replacement of fuses, pilot lamps, and/or contractor labor is not included in warranty. Damage due to acts of nature, such as, but not limited to, lightning, flooding, explosions and earthquakes, are not covered.

The warranty is limited to the repair and/or replacement of parts and/or units that upon examination at our factory and/or job site are determined to be defective and in our judgment are subject to repair or replacement. All such repair shall be manufacturer's exclusive remedy. A date code, part number and serial number identify all such units.

**TO THE EXTENT ALLOWED BY LAW, MANUFACTURER DISCLAIMS ALL OTHER WARRANTIES, EXPRESS OR IMPLIED, INCLUDING, BUT NOT LIMITED TO, AND LEED WARRANTIES OR MERCHANT ABILITY OR FITNESS FOR A PARTICULAR PURPOSE, AND ANY IMPLIED WARRANTY OF MERCHANT ABILITY OR FITNESS FOR A PARTICULAR PURPOSE ON PRODUCT IS LIMITED IN DURATION TO THE DURATION OF THIS WARRANTY. TO THE EXTENT ALLOWED BY LAW, THE MANUFACTURER SHALL NOT BE LIABLE FOR ANY SPECIAL, INCIDENTAL, OR CONSEQUENTIAL DAMAGES INCLUDING, BUT NOT LIMITED TO, LOSS OF PROFITS, INJURIES TO PROPERTY, LOSS OF USE OF THE PRODUCT OR ANY ASSOCIATED EQUIPMENT.**

Special on site extended warranties are also available upon request. The warranty period may be adjusted because of special circumstances, but only by arrangement with the manufacturer at the time of purchase.

All in or out of warranty repaired material or replacement units/parts carry a 90-day new part guarantee. Return of your original repaired component or unit is not guaranteed.

This limited warranty is for the 48 contiguous states.

For international warranty information, call the Field Service Department. See telephone number in front of manual. The standard warranty can be extended and renewed for a nominal fee. Please contact the factory for pricing information.

# SECTION 16

## CABINET DETAIL DRAWING

